



# SERVICE MANUAL

HF ALL BAND TRANSCEIVER  
GENERAL COVERAGE RECEIVER

## **IC-781**

---

---

---

---

---

---

## INTRODUCTION

---

This service manual describes the latest service information at the time of printing for the **IC-781 HF ALL BAND TRANSCEIVER** and covers the following versions:

VERSION	VERSION NUMBER
U.S.A.	#02
Australia	#03
Europe	#04
France	#05

---

## DANGER

---

Use **ONLY** the specified AC voltage described on the AC power socket. Other voltages may cause the transceiver damage or personal injury.

**DO NOT** touch the PI UNIT and REG UNIT after the transceiver is connected to an AC outlet. An insulated tool must be used at all times.

**DO NOT** expose the transceiver to rain, snow or any liquids.

**DO NOT** apply an RF signal of more than 100 mW (20 dBm) to the antenna connector. This could damage the transceiver's front-end.



---

## ORDERING PARTS

---

Be sure to include the following four points when ordering replacement parts:

1. Component part number and name
2. Equipment model name and unit name
3. 10-digit order numbers for mechanical parts
4. Quantity required

### <SAMPLE ORDER>

IC MC3357P IC-781 MAIN UNIT 5 pieces  
ICOM screw (B) 5 IC-781 Top cover 8810003710 10 pieces

---

## REPAIR NOTE

---

1. Make sure a problem is internal before disassembling the transceiver.
2. **DO NOT** open the transceiver until the transceiver is disconnected from a power source.
3. **DO NOT** force any of the variable components. Turn them slowly and smoothly.
4. **DO NOT** short any circuits or electronic parts. An insulated tuning tool **MUST** be used for all adjustments.
5. **DO NOT** keep power ON for a long time when the transceiver is defective.
6. **DO NOT** transmit power into a signal generator or a sweep generator.
7. **ALWAYS** connect a 30 dB~40 dB attenuator between the transceiver and a deviation meter or spectrum analyzer when using such test equipment.
8. **READ** the instructions of test equipment thoroughly before connecting equipment to the transceiver.



## TABLE OF CONTENTS

<b>SECTION</b>	<b>1</b>	<b>SPECIFICATIONS</b> .....	<b>1 — 1 ~ 2</b>
<b>SECTION</b>	<b>2</b>	<b>OUTSIDE AND INSIDE VIEWS</b> .....	<b>2 — 1 ~ 5</b>
	2-1	OUTSIDE VIEWS .....	2 — 1
	2-2	INSIDE VIEWS .....	2 — 3
<b>SECTION</b>	<b>3</b>	<b>BLOCK DIAGRAM</b> .....	<b>3 — 1</b>
<b>SECTION</b>	<b>4</b>	<b>CIRCUIT DESCRIPTION</b> .....	<b>4 — 1 ~ 21</b>
	4-1	RECEIVER CIRCUITS .....	4 — 1
	4-2	TRANSMITTER CIRCUITS .....	4 — 8
	4-3	PLL CIRCUITS .....	4 — 13
	4-4	LOGIC CIRCUITS .....	4 — 16
	4-5	SCOPE UNIT .....	4 — 18
	4-6	ANTENNA TUNER CIRCUITS .....	4 — 18
	4-7	POWER SUPPLY CIRCUITS .....	4 — 19
<b>SECTION</b>	<b>5</b>	<b>MECHANICAL PARTS AND DISASSEMBLY</b> .....	<b>5 — 1 ~ 19</b>
	5-1	FRAME DISASSEMBLY (1) .....	5 — 1
	5-2	FRAME DISASSEMBLY (2) .....	5 — 2
	5-3	FRAME DISASSEMBLY (3) .....	5 — 4
	5-4	FRONT PANEL DISASSEMBLY (1) .....	5 — 6
	5-5	FRONT PANEL DISASSEMBLY (2) .....	5 — 10
	5-6	REAR PANEL (PA AND REG UNITS) DISASSEMBLY .....	5 — 12
	5-7	TUNER UNIT DISASSEMBLY .....	5 — 14
	5-8	FRONT UNIT CONNECTOR ASSEMBLY .....	5 — 16
	5-9	TOP VIEW CONNECTOR ASSEMBLY .....	5 — 17
	5-10	BOTTOM VIEW CONNECTOR ASSEMBLY .....	5 — 18
	5-11	PLL-A AND PLL-B UNITS REMOVAL .....	5 — 19
<b>SECTION</b>	<b>6</b>	<b>ADJUSTMENT PROCEDURES</b> .....	<b>6 — 1 ~ 41</b>
	6-1	BEFORE ADJUSTMENT .....	6 — 1
	6-2	PLL ADJUSTMENT .....	6 — 2
	6-3	FREQUENCY ADJUSTMENT .....	6 — 8
	6-4	RECEIVER ADJUSTMENT .....	6 — 12
	6-5	TRANSMITTER ADJUSTMENT .....	6 — 20
	6-6	SPECTRUM SCOPE ADJUSTMENT .....	6 — 32
	6-7	TUNER UNIT ADJUSTMENT .....	6 — 38
	6-8	SWITCHING REGULATOR ADJUSTMENT .....	6 — 40
<b>SECTION</b>	<b>7</b>	<b>BOARD LAYOUTS</b> .....	<b>7 — 1 ~ 26</b>
	7-1	FRONT UNIT (1) .....	7 — 1
	7-2	FRONT UNIT (2) .....	7 — 2
	7-3	FRONT UNIT (3) .....	7 — 4
	7-4	MAIN AND IDC UNITS .....	7 — 6
	7-5	IF, VOX, CM AND SWR UNITS .....	7 — 8
	7-6	RF UNIT .....	7 — 10
	7-7	PLL-A AND DDS-A UNITS .....	7 — 12
	7-8	PLL-B AND DDS-B UNITS .....	7 — 14
	7-9	LOGIC-A AND CRTIC UNITS .....	7 — 16
	7-10	LOGIC-B UNIT .....	7 — 18
	7-11	SCOPE UNIT .....	7 — 19
	7-12	PI UNIT .....	7 — 19
	7-13	PA UNIT .....	7 — 21
	7-14	REG, TR, DI AND DC-DC UNITS .....	7 — 22
	7-15	FILTER UNIT .....	7 — 24
	7-16	TUNER UNIT .....	7 — 25
	7-17	EF (CONNECTOR 1, 2) UNIT .....	7 — 26

<b>SECTION 8</b>	<b>IC PIN CONNECTIONS</b> .....	<b>8 — 1 ~ 6</b>
<b>SECTION 9</b>	<b>VOLTAGE DIAGRAMS</b> .....	<b>9 — 1 ~ 10</b>
9-1	FRONT UNIT .....	9 — 1
9-2	MAIN AND IDC UNITS .....	9 — 2
9-3	IF, VOX, CM AND SWR UNITS .....	9 — 3
9-4	RF UNIT .....	9 — 4
9-5	PLL-A AND DDS-A UNITS .....	9 — 5
9-6	PLL-B AND DDS-B UNITS .....	9 — 6
9-7	LOGIC-A AND CRTIC UNITS .....	9 — 7
9-8	LOGIC-B AND SCOPE UNITS .....	9 — 8
9-9	PI, PA, REG, FILTER AND DC-DC UNITS .....	9 — 9
9-10	TUNER AND CONNECTOR 1, 2 UNITS .....	9 — 10
<b>SECTION 10</b>	<b>PARTS LIST</b> .....	<b>10 — 1 ~ 48</b>

**The SCHEMATIC DIAGRAMS are attached at the end of this service manual.**

# SECTION 1 SPECIFICATIONS

## ■ GENERAL

- Frequency coverage : Receive: 0.1000~30.0000 MHz  
 Transmit: 160m band 1.8000~ 2.0000 MHz  
 80m band 3.4000~ 4.1000 MHz  
 40m band 6.9000~ 7.5000 MHz  
 30m band 9.9000~10.5000 MHz  
 20m band 13.9000~14.5000 MHz  
 17m band 17.9000~18.5000 MHz  
 15m band 20.9000~21.5000 MHz  
 12m band 24.4000~25.1000 MHz  
 10m band 27.9000~30.0000 MHz
- Modes : A3J (SSB), A1 (CW), F3 (FM), F1 (RTTY), A3 (AM)
- Frequency step : 10 Hz, (With [TS] OFF) 1 kHz (With [TS] ON)
- Frequency stability :  $\pm 15$  Hz ( $-10^{\circ}\text{C} \sim +60^{\circ}\text{C}$ ) ( $+14^{\circ}\text{F} \sim +140^{\circ}\text{F}$ )
- Antenna impedance : 50  $\Omega$  unbalanced (With [TUNER] OFF)
- Power supply requirement : U.S.A. version AC 100~120 V  
 Australia, Europe, France versions AC 200~240 V
- Power consumption : Transmitting HIGH: 760 VA LOW: 325 VA  
 Receiving max. audio: 150 VA standby: 140 VA
- Dimensions : 425(W)  $\times$  149(H)  $\times$  411(D) mm 16.7(W)  $\times$  5.9(H)  $\times$  16.2(D) in.  
 (Projections not included)
- Weight : 23 kg (50.8 lbs)
- Usable temperature range :  $-10^{\circ}\text{C} \sim +60^{\circ}\text{C}$  ( $+14^{\circ}\text{F} \sim +140^{\circ}\text{F}$ )

## ■ TRANSMITTER

- Output power : SSB 150 W PEP  
 CW, RTTY, FM 150 W  
 AM 75 W
- Modulation : SSB Balanced modulation  
 FM Reactance modulation  
 AM Low level modulation
- Max. frequency deviation :  $\pm 5$  kHz
- RTTY shift width : 170 Hz, 425 Hz, 850 Hz selectable
- Spurious emissions : Less than  $-60$  dB
- Carrier suppression : Less than  $-40$  dB
- Unwanted sideband : Less than  $-55$  dB with 1000 Hz modulation
- Microphone impedance : 600  $\Omega$

## ■ RECEIVER

- Receive system : SSB, CW, RTTY, AM Quadruple-conversion superheterodyne  
 FM Triple-conversion superheterodyne
- Intermediate frequencies :

	SSB	CW, RTTY	AM	FM
1st	46.5115	46.5106	46.5100	46.5100
2nd	9.0115	9.0106	9.0100	9.0100
3rd	0.4550	0.4550	0.4550	0.4550
4th	10.6950	10.6950	10.6950	—

(Unit: MHz)

- Sensitivity ([PREAMP] ON) : SSB, CW, RTTY (for 10 dB S/N) 0.1~0.5 MHz Less than 0.5  $\mu$ V  
0.5~1.8 MHz Less than 1.0  $\mu$ V  
1.8~30 MHz Less than 0.16  $\mu$ V  
AM (for 10 dB S/N) 0.1~0.5 MHz Less than 3.2  $\mu$ V  
0.5~1.8 MHz Less than 6.3  $\mu$ V  
1.8~30 MHz Less than 1.0  $\mu$ V  
FM (for 12 dB SINAD) 28~30 MHz Less than 0.23  $\mu$ V
- FM squelch sensitivity : 28~30 MHz Less than 0.23  $\mu$ V
- Selectivity : SSB, CW-W, RTTY-W, AM-N: More than 2.4 kHz/−6 dB  
Less than 3.8 kHz/−60 dB  
CW-N, RTTY-N (With [CW250 Hz] OFF): More than 500 Hz/−6 dB  
Less than 1.0 kHz/−60 dB  
CW-N, RTTY-N (With [CW250 Hz] ON): More than 250 Hz/−6 dB  
Less than 800 Hz/−60 dB  
AM-W: More than 6.0 kHz/−6 dB  
Less than 15.0 kHz/−60 dB  
FM: More than 15.0 kHz/−6 dB  
Less than 30.0 kHz/−50 dB
- Spurious and image rejection ratio : Image: Less than −80 dB IF: Less than −70 dB
- Audio output power : More than 2.6 W at 10 % distortion with an 8  $\Omega$  load
- Notch filter attenuation : More than 45 dB
- RIT variable range :  $\pm$ 9.99 kHz

## ■ ANTENNA TUNER

- Output matching range : 16.7~150  $\Omega$  unbalanced
- Minimum input power : 15 W
- Band switching time : Less than 3 sec.
- Auto tuning time : Less than 3 sec.
- Auto tuning accuracy : VSWR less than 1.2 : 1
- Insertion loss : Less than 0.5 dB (after tuning)

## ■ CRT DISPLAY

- Output level : Composite video signal: 1 Vp-p  
Video components: 0.7 Vp-p positive  
Synchronous components: 0.3 Vp-p negative
- Output impedance : 75  $\Omega$
- Usable humidity range : 10~90 % (Keep the transceiver away from moist environments.)
- Horizontal frequency : 15.75 kHz
- Vertical frequency : 60 Hz

※ All stated specifications are subject to change without notice or obligation.

# SECTION 2 OUTSIDE AND INSIDE VIEWS

## 2-1 OUTSIDE VIEWS

### 2-1-1 FRONT PANEL

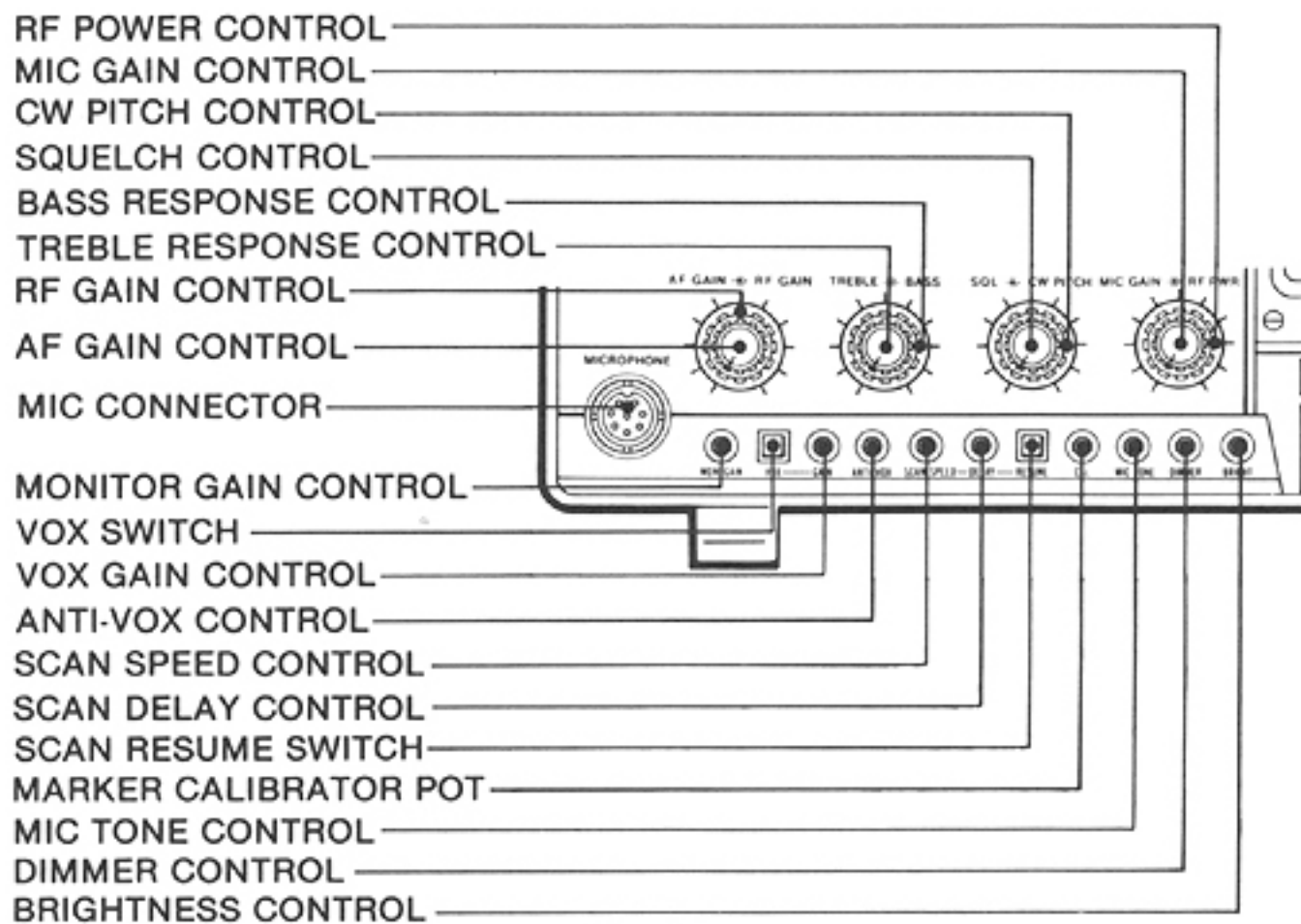
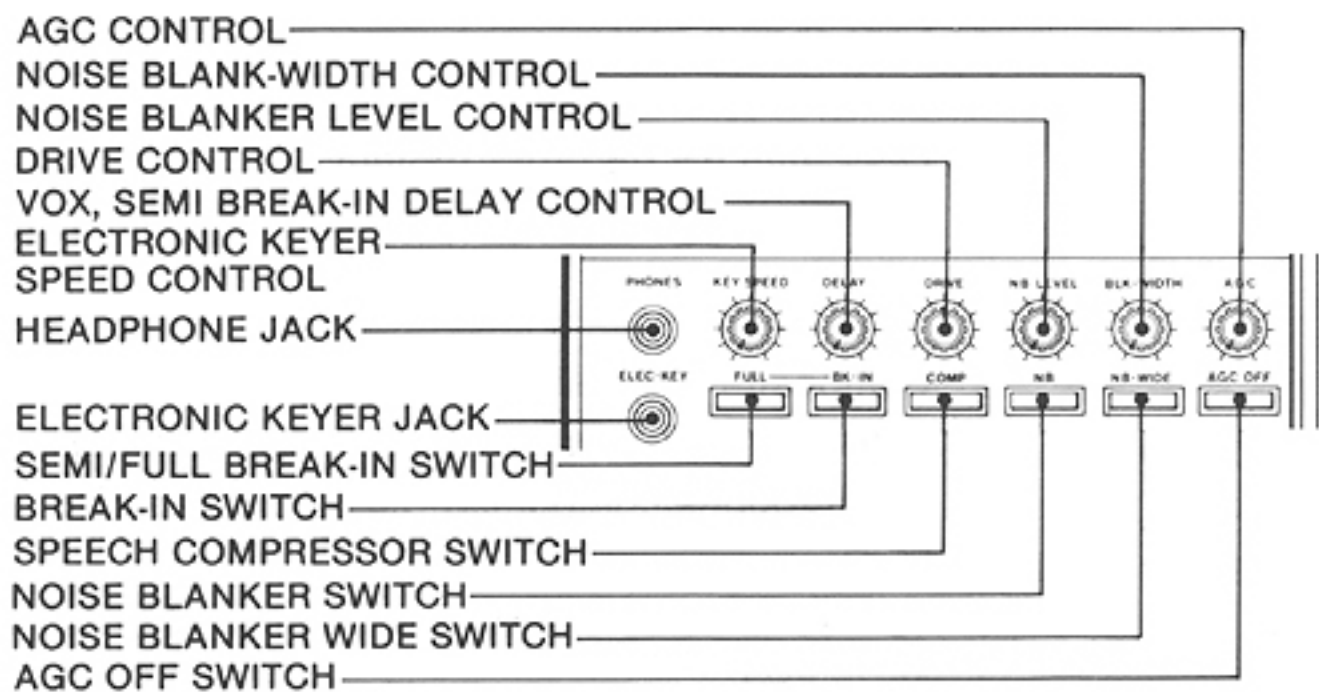
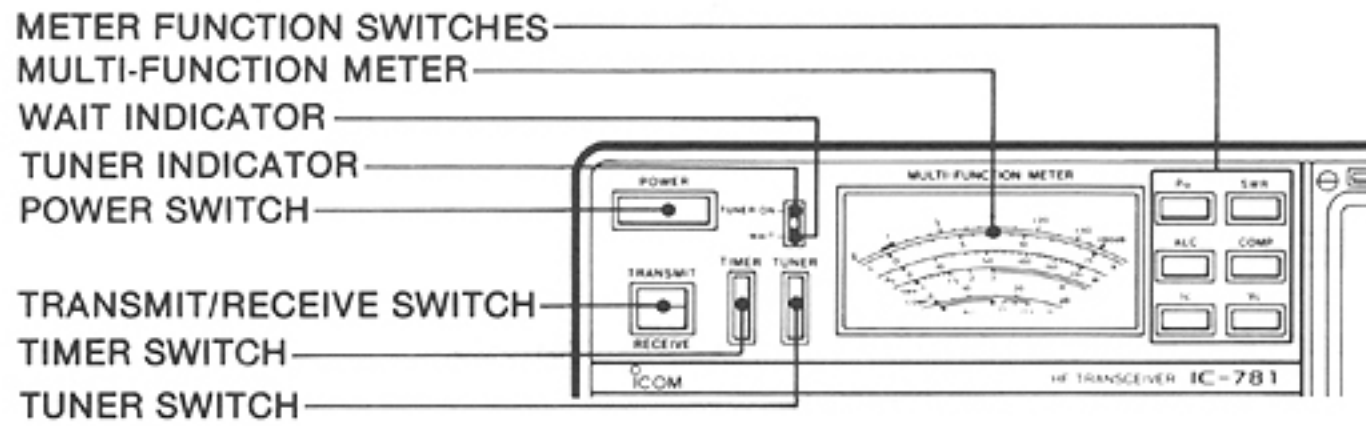
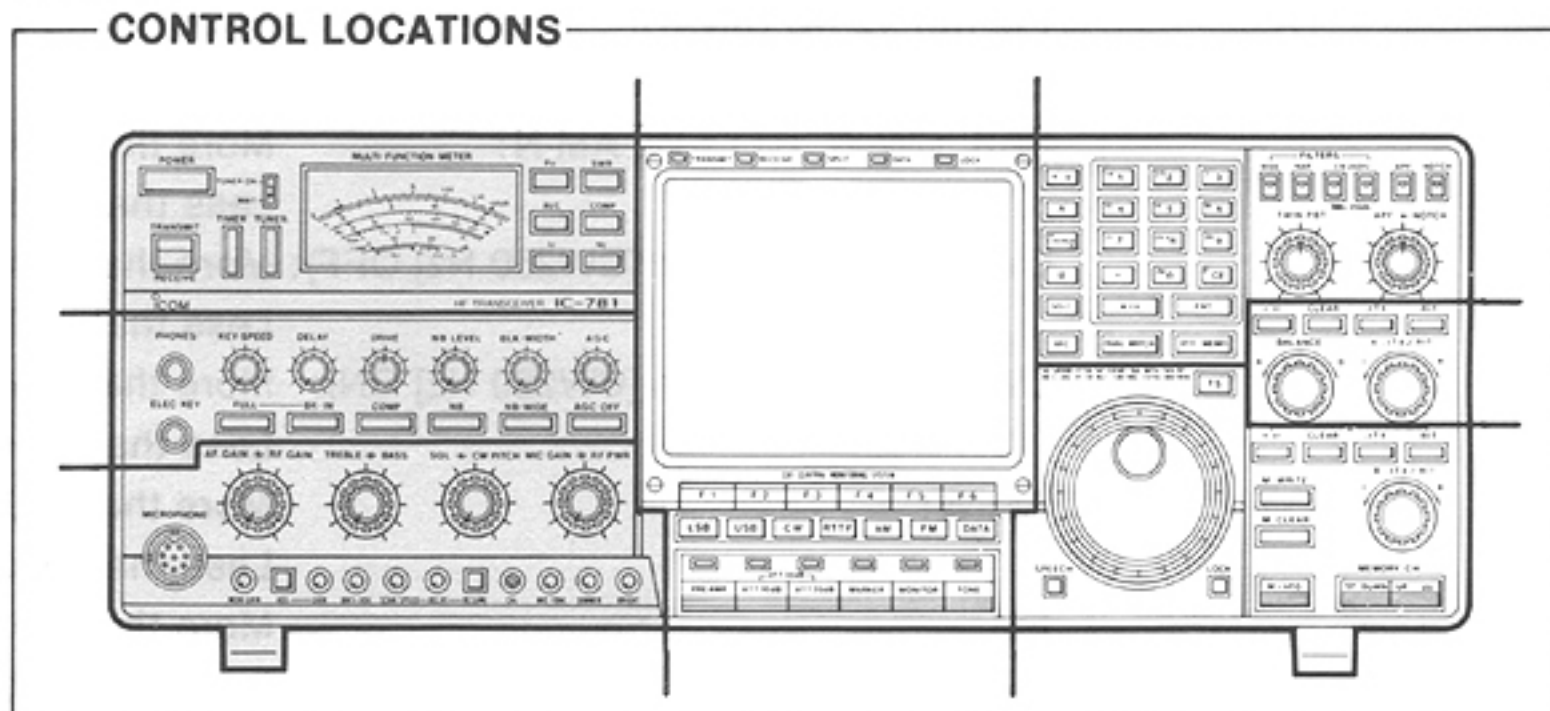



• FRONT PANEL (CONTINUED)

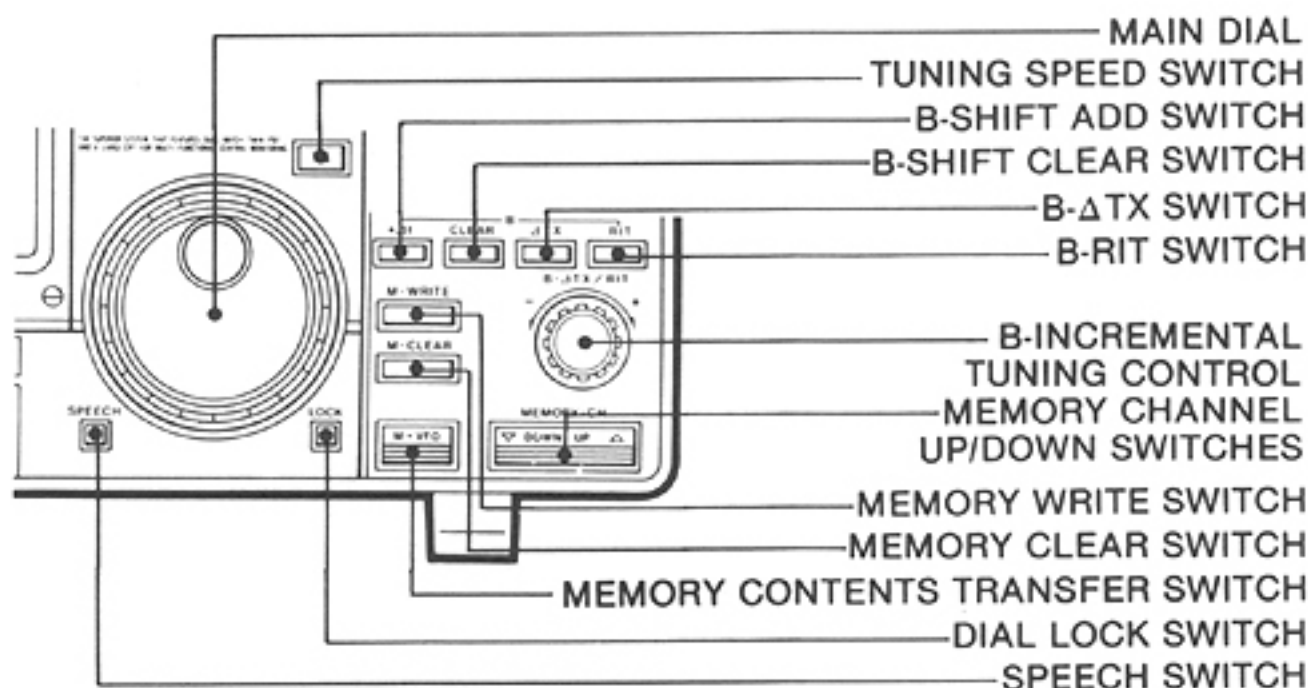
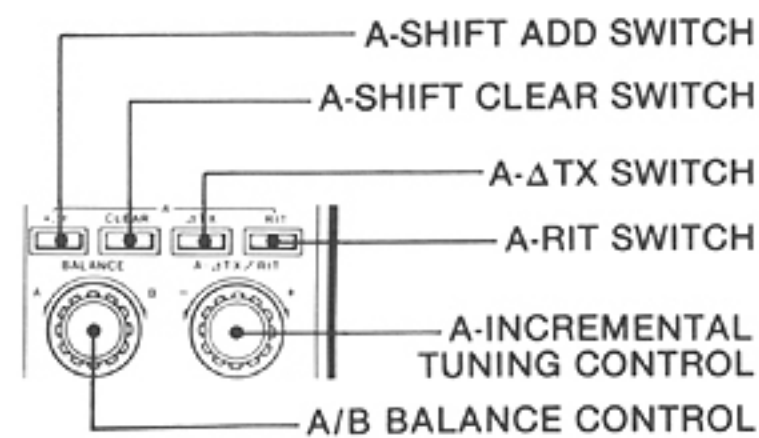
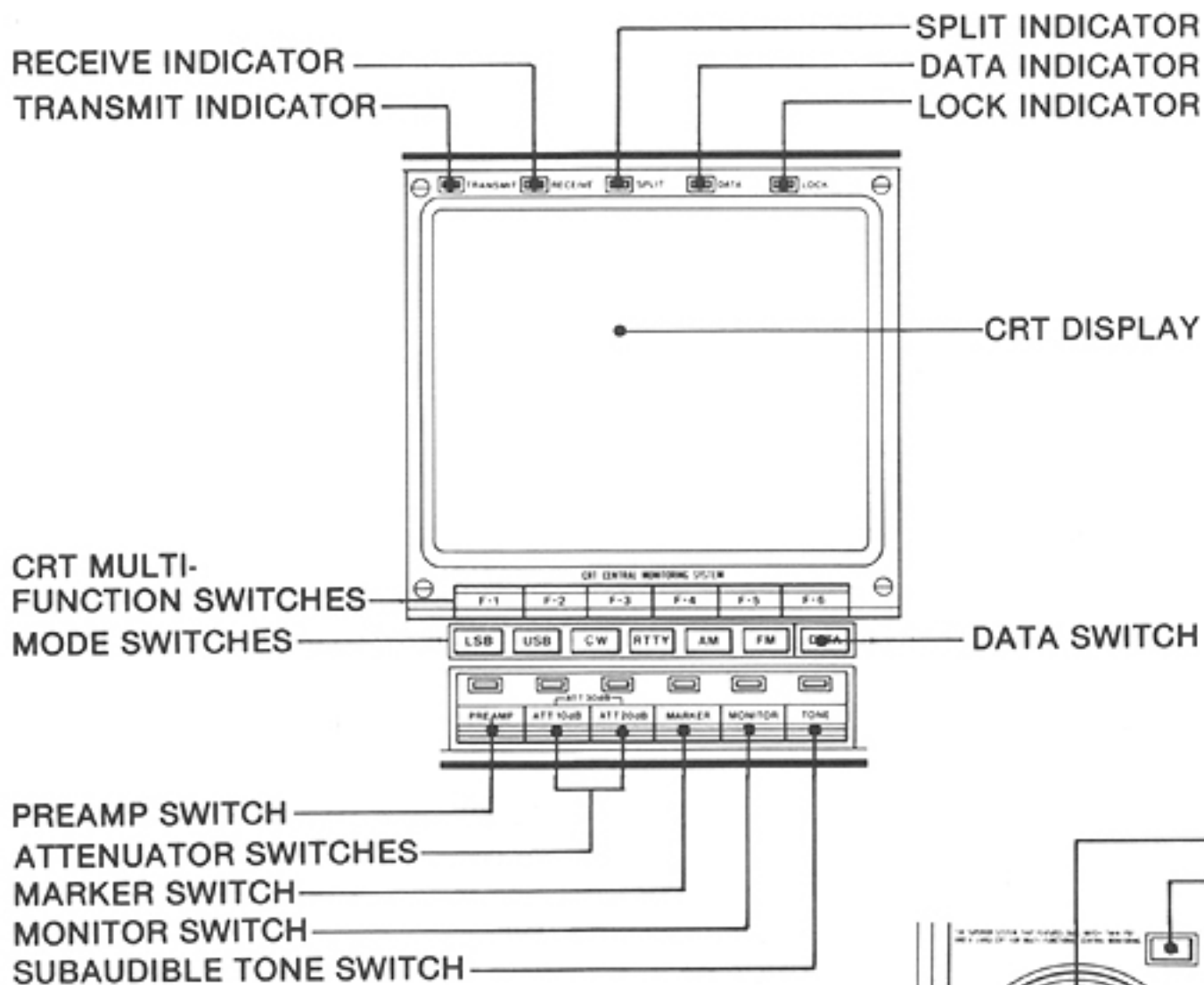
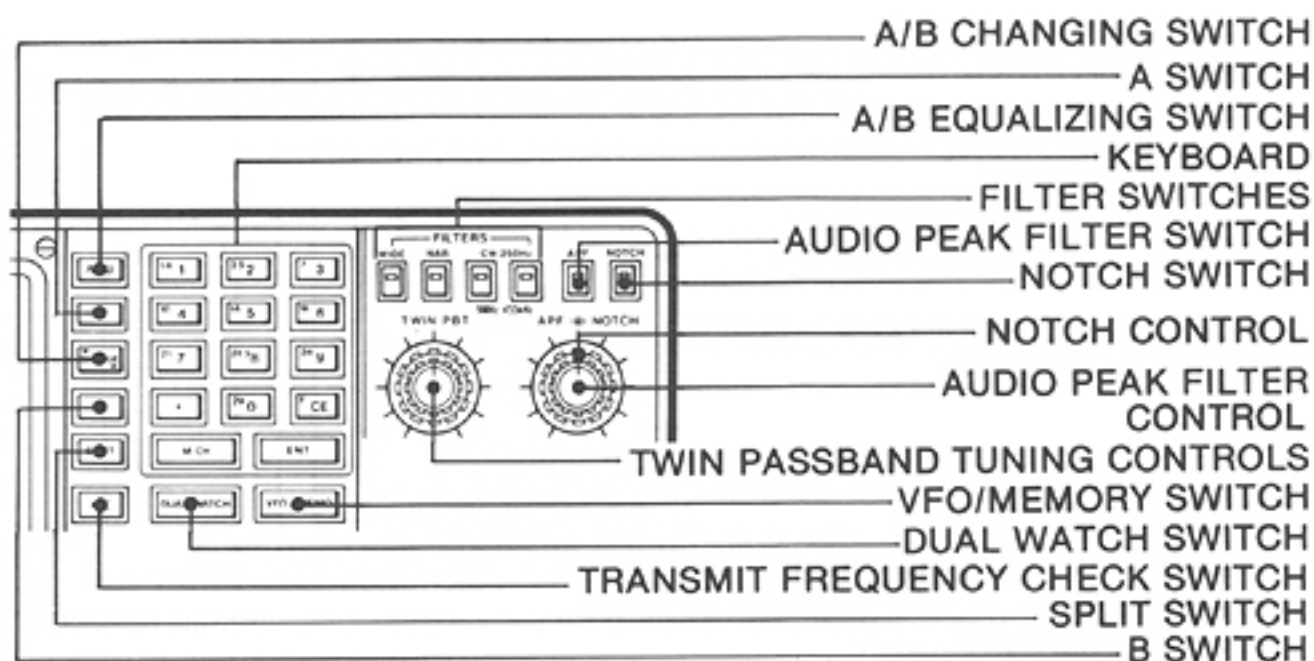
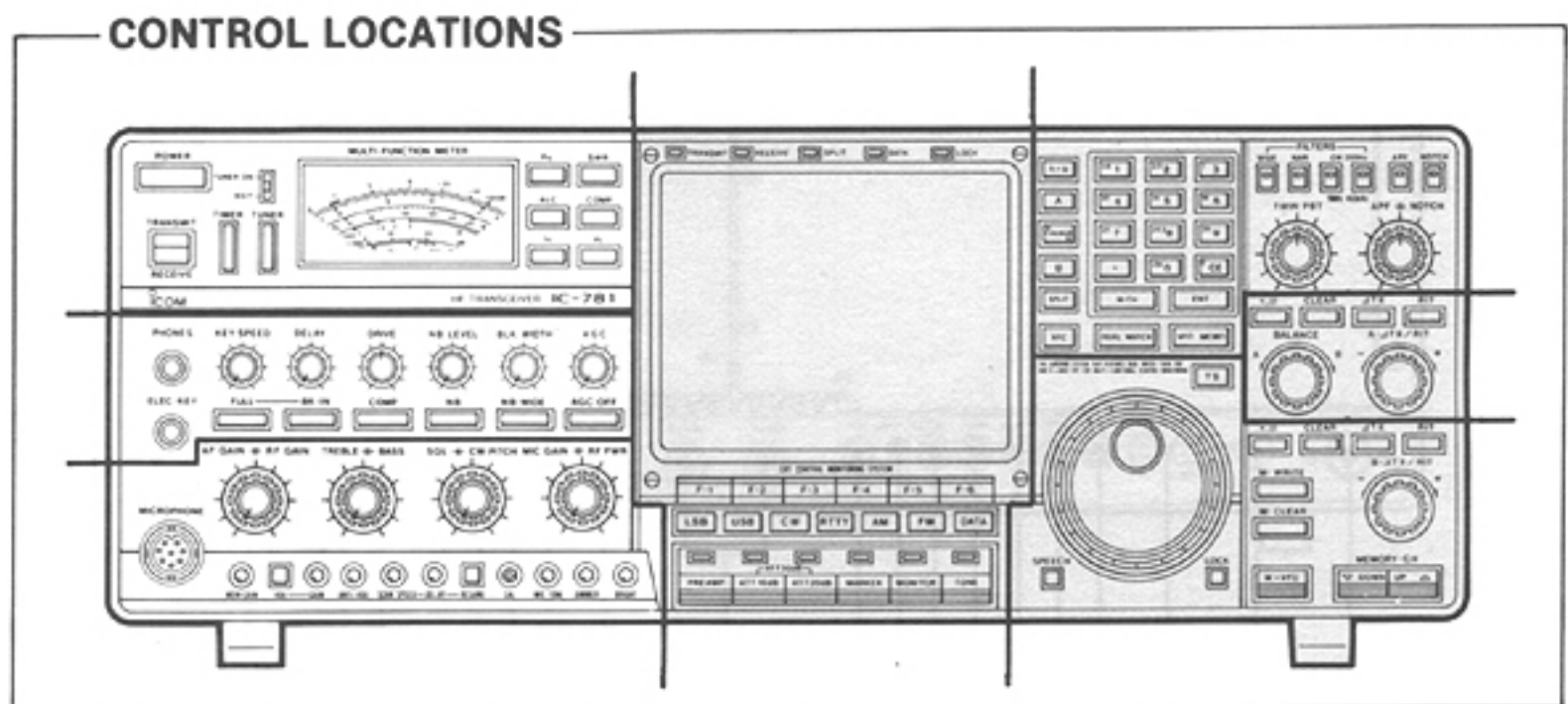

## 2-1-2 REAR PANEL

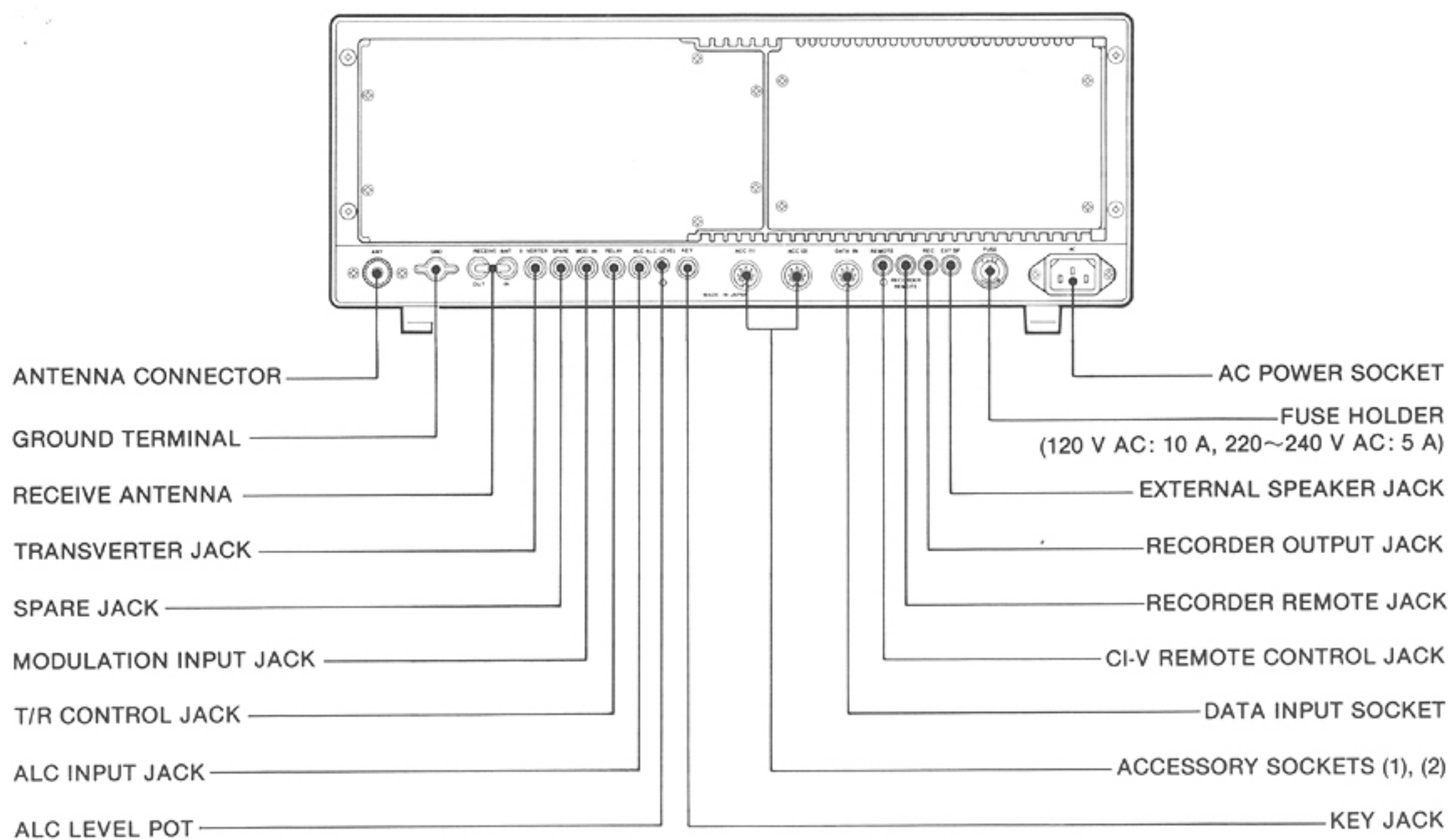

## 2-2 INSIDE VIEWS

### 2-2-1 TOP VIEW

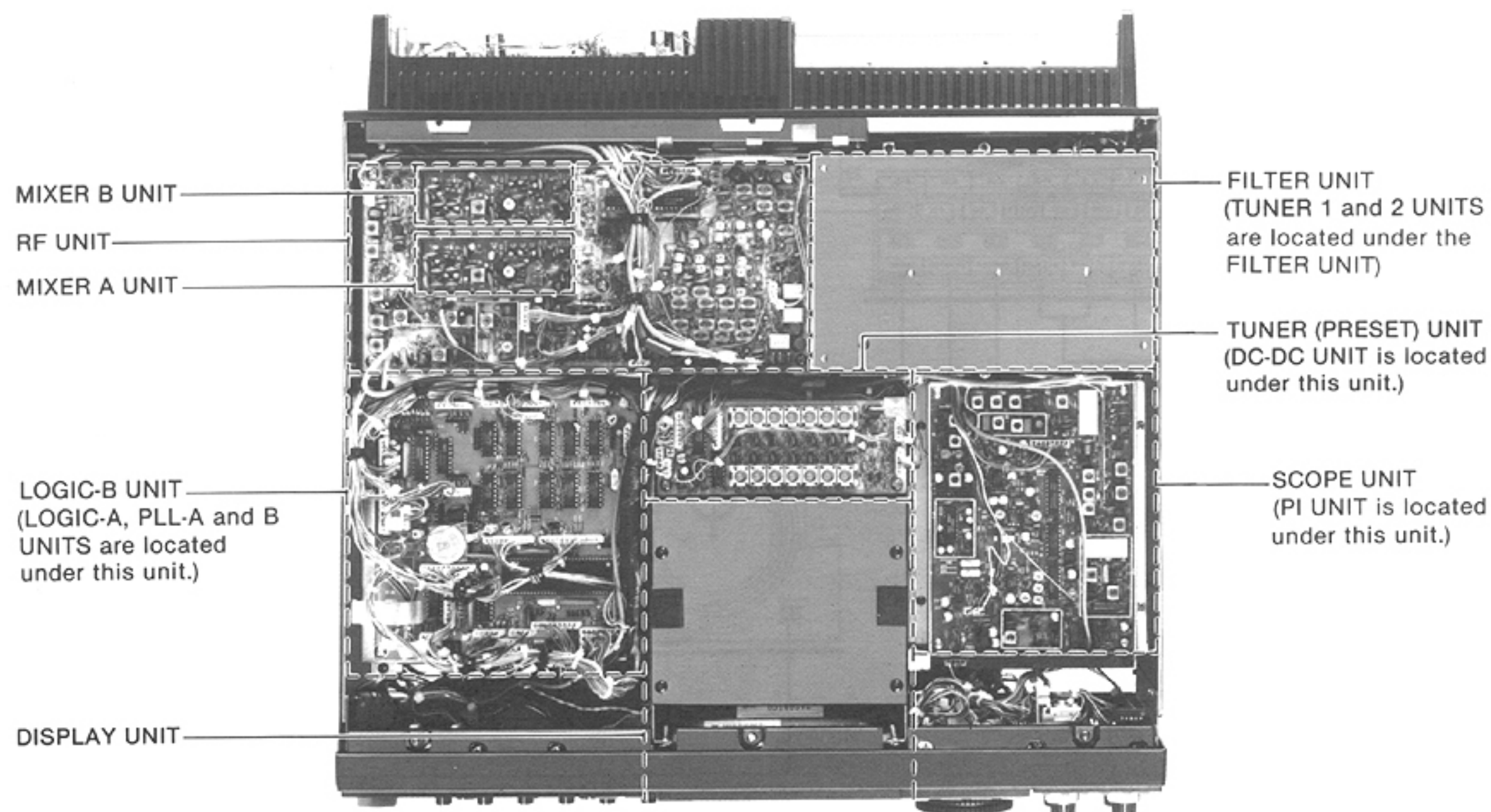

## 2-2-2 BOTTOM VIEW

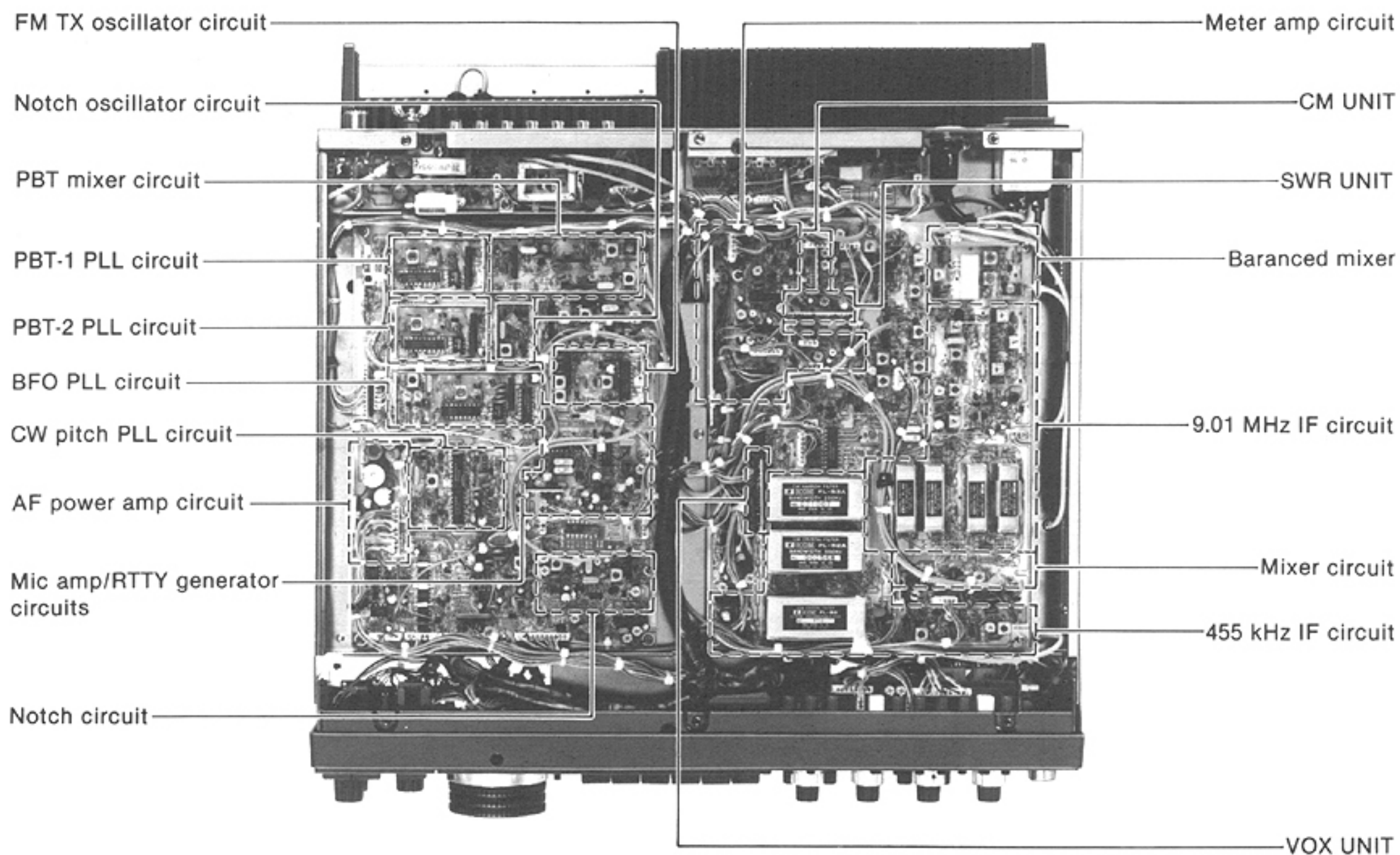

## 2-2-3 REAR VIEW (REG, TR, DI AND PA UNITS)

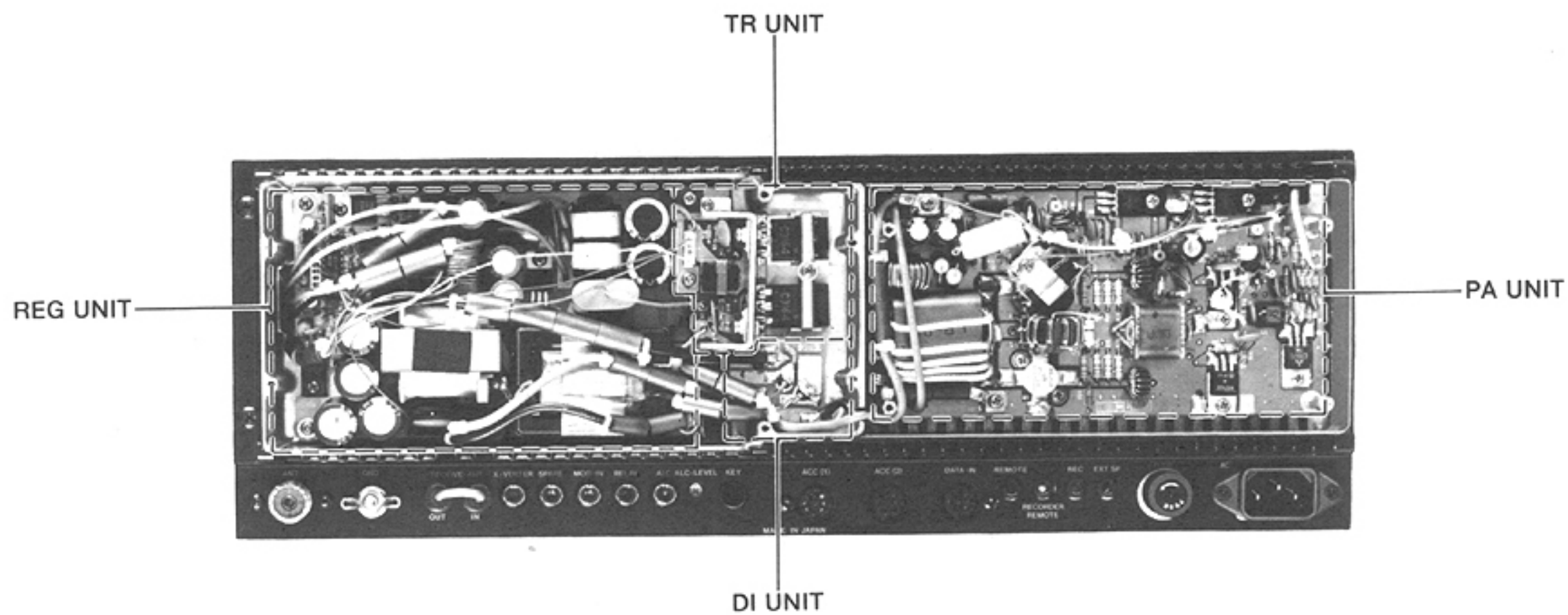



## 2-2-4 TUNER UNIT

### • TOP VIEW

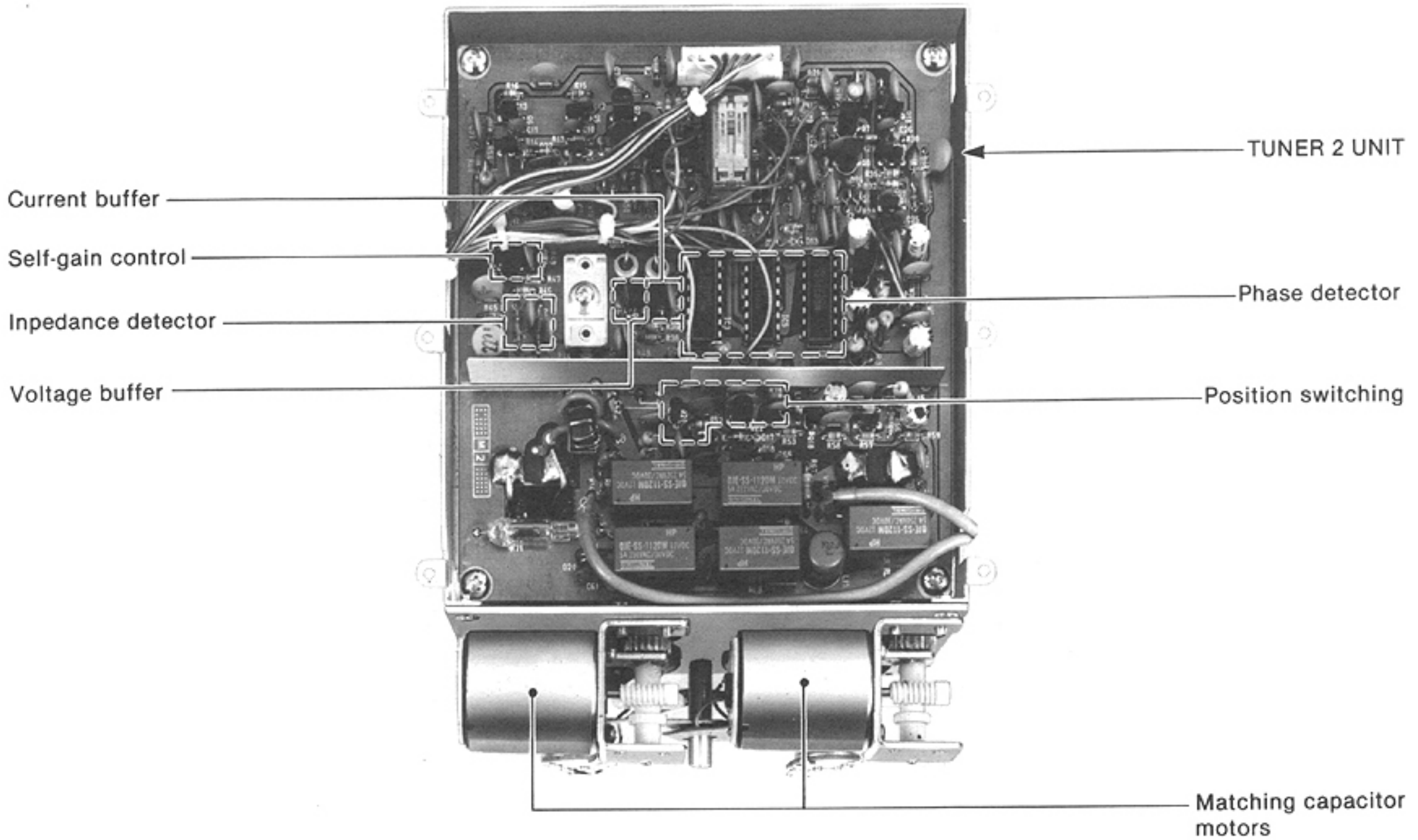

### • BOTTOM VIEW

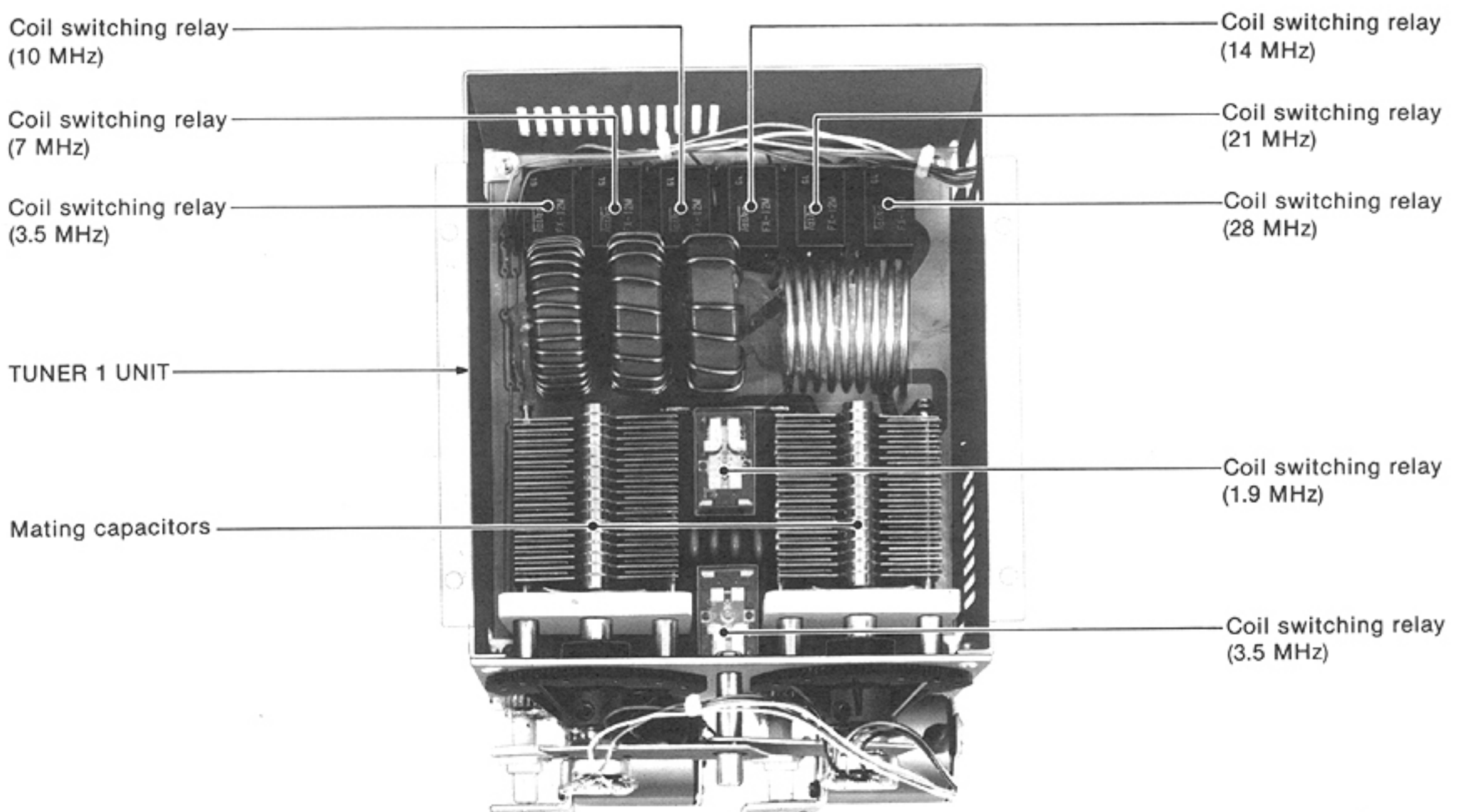





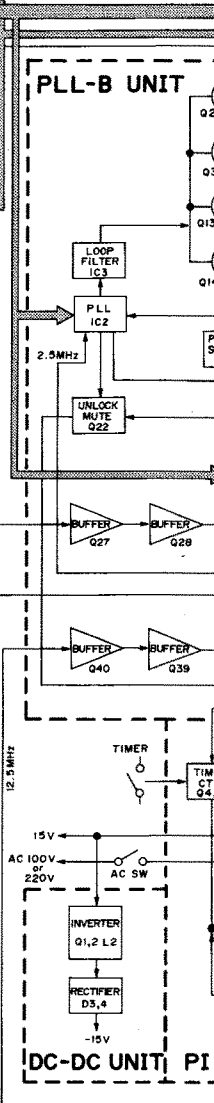
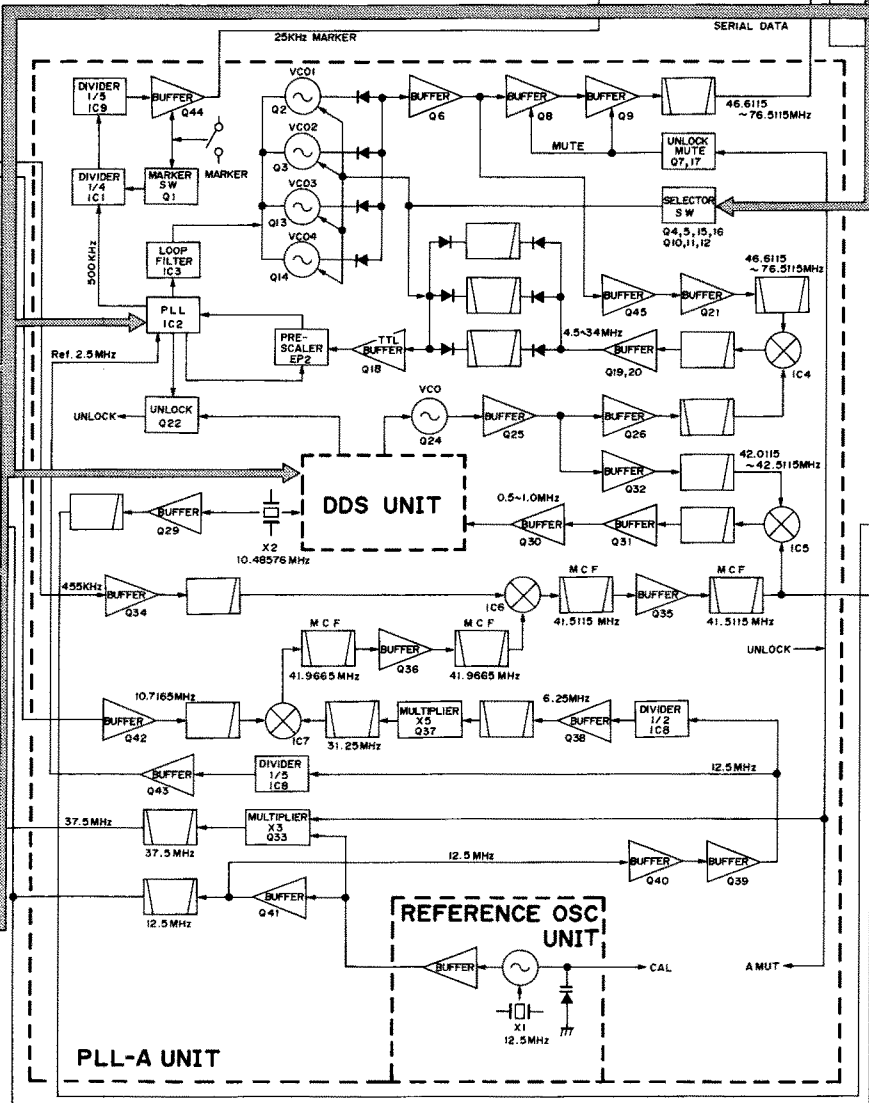
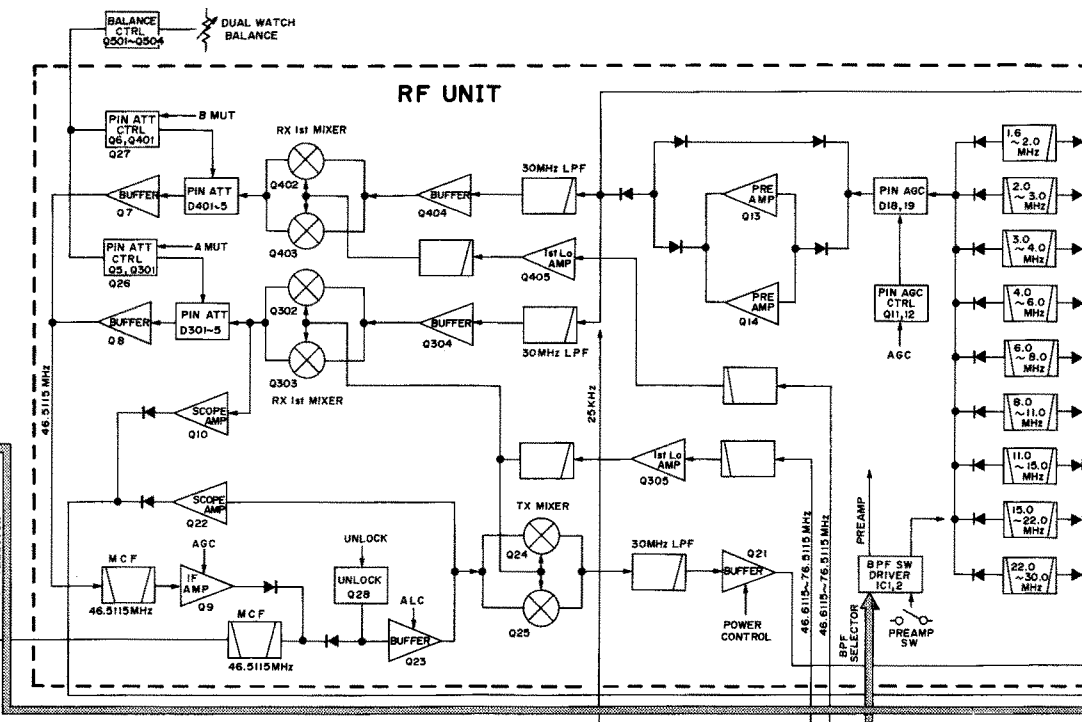
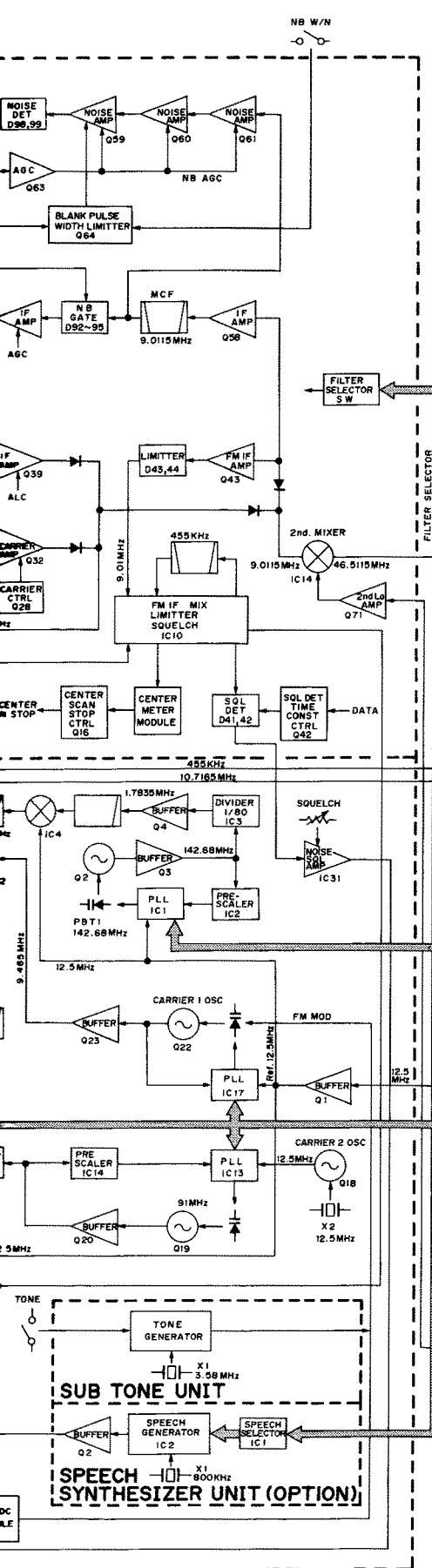

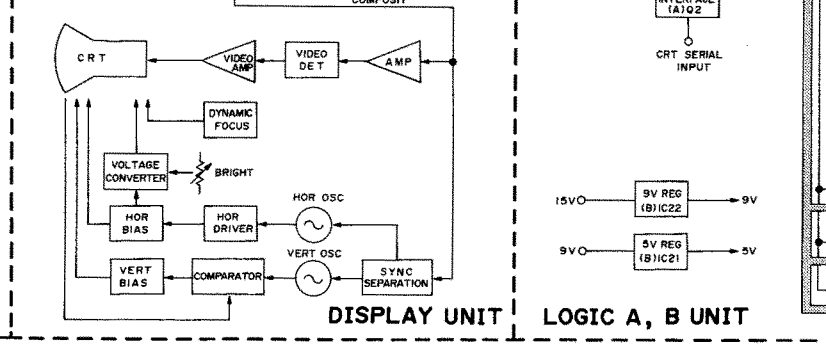
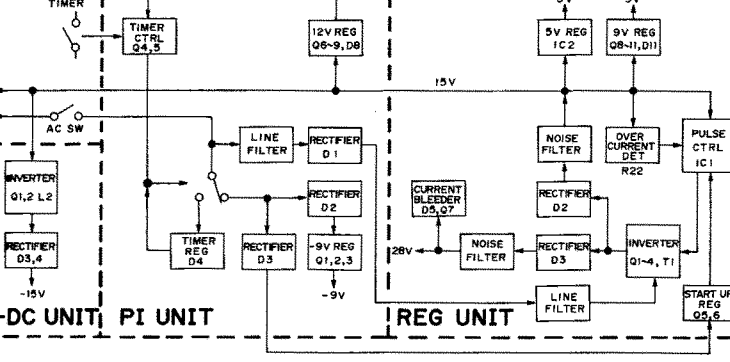
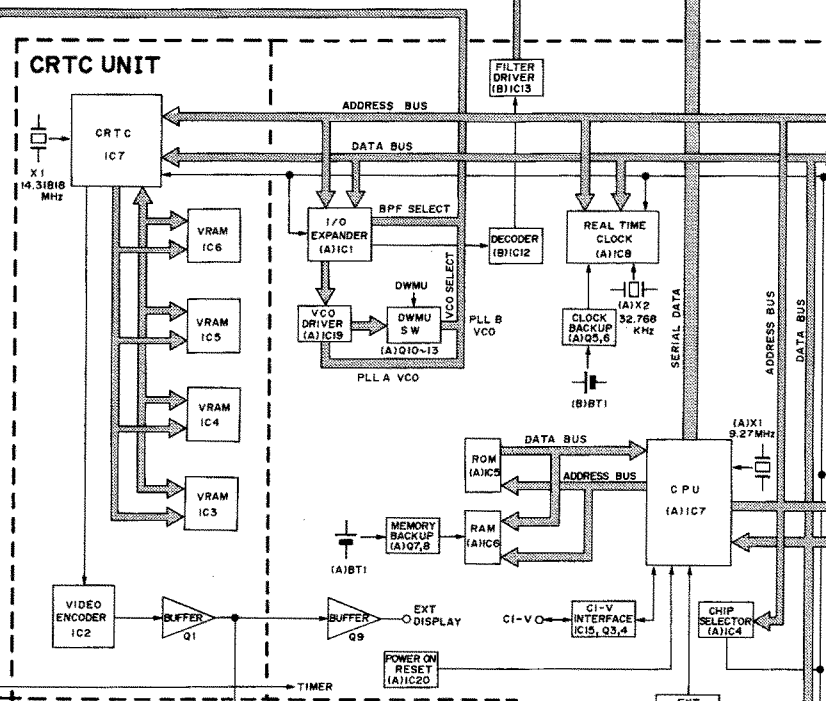
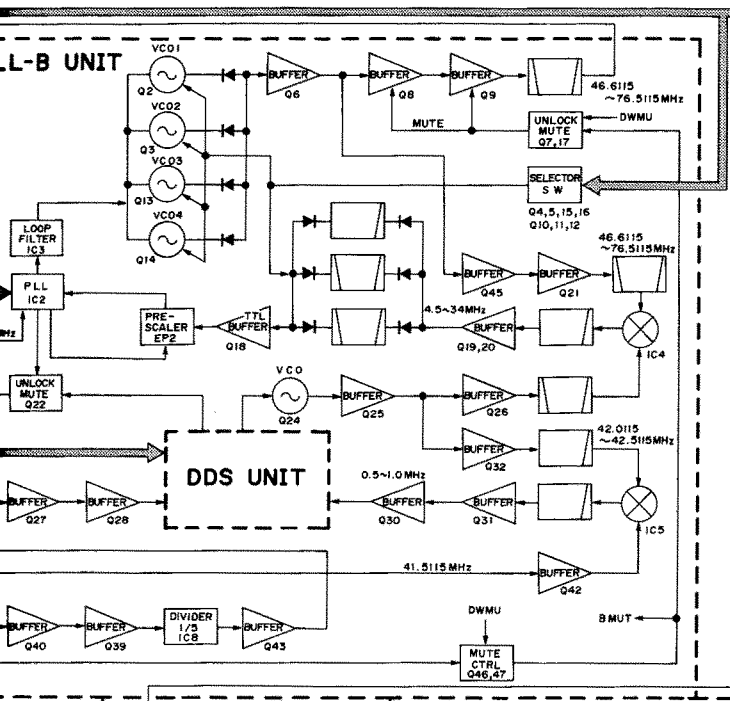
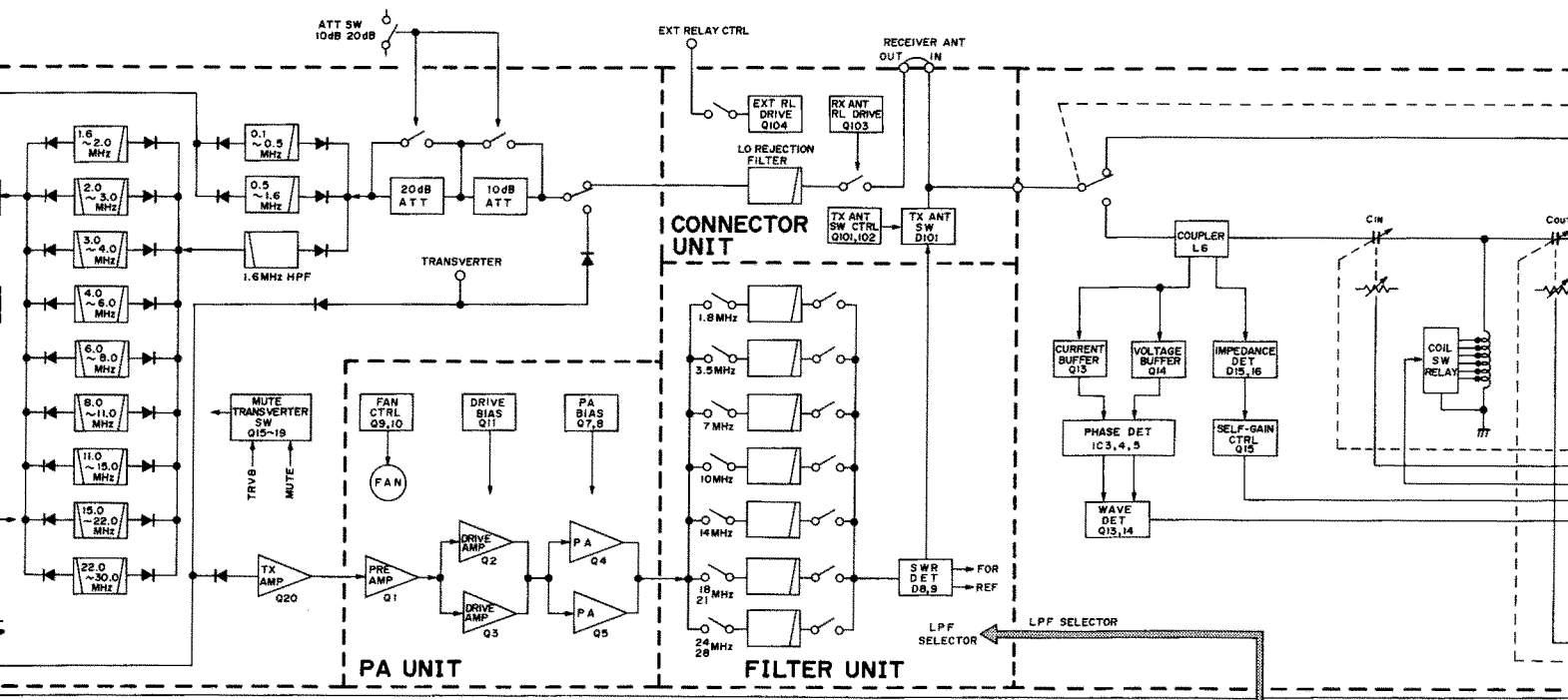



## SECTION 4 CIRCUIT DESCRIPTION

### 4-1 RECEIVER CIRCUITS

#### 4-1-1 RF SWITCHING CIRCUIT (RF UNIT AND CONNECTOR 2 UNIT)

RF signals from the antenna connector pass through the TUNER UNIT, the receive line switching relay (RL101), the [RECEIVE-ANT] jacks and a low-pass filter, and are applied to the RF UNIT via P101 (RF UNIT: J9). RL101 is a reed relay and is used for switching relay corresponding to the full break-in switching speed.

The signals applied to the RF UNIT pass through the transverter switching relay (RL3) and either bypass or are selectively attenuated at 10 dB or 20 dB attenuators (30 dB when passing through both attenuators). The signals are then applied to RF filters.

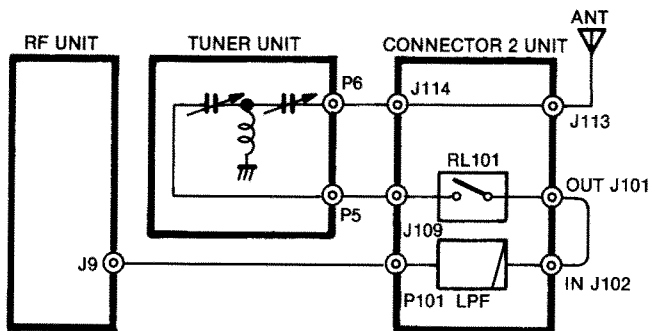

Fig. 1

#### 4-1-2 RF BANDPASS FILTER (RF UNIT)

The RF UNIT has eight RF bandpass filters for signals above 2.0 MHz and three low-pass filters for signals below 2.0 MHz. The signals pass through one of the bandpass or low-pass filters depending on the receive frequency range.

##### (1) 0.1~0.5 MHz

Signals are applied to a low-pass filter via D21. Diodes (D20, D21) are turned ON when the "B1" line is "HIGH." Filtered signals are applied to the hybrid distributor (L41) via D20.

##### (2) 0.5~1.6 MHz

Signals are applied to a low-pass filter via D23. Diodes (D22, D23) are turned ON when the "B2" line is "HIGH." Filtered signals are applied to the hybrid distributor (L41) via D22.

##### (3) 1.6 MHz AND ABOVE

Signals are applied via D42 to a high-pass filter consisting of L109~L112, C142~C147. This filter suppresses strong signals below 1.6 MHz such as a broadcasting station.

Filtered signals below 2.0 MHz are applied to a low-pass filter via D25. Diodes (D24, D25) are turned ON when the "B3" line is "HIGH."

Filtered signals above 2.0 MHz are applied to one of eight bandpass filters depending on the frequency of the signals.

After passing through a bandpass or low-pass filter, the signals are applied to the L-type attenuator by using D18 and D19. The attenuator functions as an RF AGC circuit. These diodes are pin diodes and are controlled by AGC bias voltage via Q11 and Q12. By combining two diodes D18 and D19, the input impedance of the circuit is maintained at approximately 50 Ω. When strong signals are received, the AGC circuit increases the attenuation level, preventing front-end overloading.

When the [PREAMP] switch is turned ON, the signals from the attenuator are amplified by the preamplifier circuit (Q13, Q14). The preamplifier provides a 10 dB gain over a wideband frequency range. When the [PREAMP] switch is turned OFF, the signals bypass the preamplifier through D15 and D16. Amplified or bypassed signals are applied to the hybrid distributor (L41) via D13.

#### PREAMP CIRCUIT

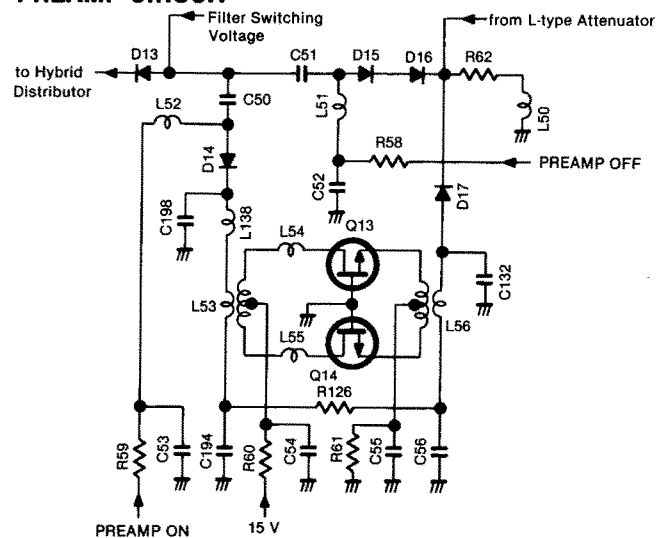

Fig. 2

#### (4) FILTER SWITCHING CIRCUIT

BPF or LPF switching voltage (B1'~B11') is obtained via IC1 and IC2 by decoding band signals (B1~B11) from the LOGIC-A UNIT. A diode switching current from the BPF or LPF is applied to contacts of the relay (RL1~RL3) to prevent bad contacts.

## 4-1-3 1ST MIXER CIRCUITS (MIXER A AND MIXER B UNITS)

IC-781 has two mixer circuits for Dual Watch operation. The MIXER A and B UNITS are used for receiving on the "A" and "B" section frequencies respectively.

When Dual Watch is OFF, the local oscillator signal for the MIXER B UNIT is cut off at Q405. Only the MIXER A UNIT is activated as follows:

The signals are distributed at the hybrid distributor (L41) with an insertion loss of 3 dB. Each distributed signal is then applied to a low-pass filter cut off at 30 MHz. Signals enter the MIXER A UNIT.

Signals entering the MIXER A UNIT are buffer-amplified at Q304. Q304 functions as a grounded-gate buffer amplifier which has excellent reverse isolation—ensuring that mixed signals in the MIXER A and B UNITS do not affect each other. L310 and C329 trap 46.51 MHz signals. C328 and C330 provide impedance matching.

The signals enter the 1st mixer circuit (Q302 and Q303) to be converted to a 46.51 MHz 1st IF signal.

### 1ST IF SIGNAL IN EACH MODE

MODE	FREQUENCY (MHz)
SSB	46.5115
CW, RTTY	46.5106
FM, AM	46.5100

The 1st mixer circuit employs a balanced mixer using low-noise junction FETs (2SK125×2) to expand the dynamic range.

### TWO-SIGNAL RECEIVE CHARACTERISTICS

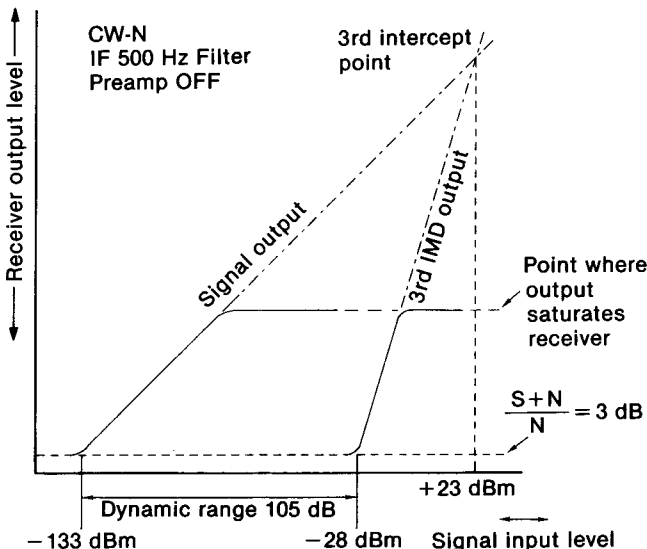

Fig. 3

The 1st LO signal (46.6115~76.5115 MHz) enters the RF UNIT from the PLL-A UNIT via J7. The signal is filtered by a high-pass filter, amplified at Q305, filtered by a low-pass filter, and then applied to the 1st mixer circuit (Q302 and Q303).

When Dual Watch is ON, the "DUAL" signal from the MODE SW UNIT via IC2 activates the 1st LO buffer (Q405) in the MIXER B UNIT. MIXER B UNIT operation is identical to that of the MIXER A UNIT.

Two-stage  $\pi$  network attenuators using pin diodes (D301~D305, D401~D405) are activated during Dual Watch operation. Attenuation balance is controlled by the [BALANCE] control through the "MIXA" and "MIXB" lines.

When Dual Watch is OFF, the "MIXA" line is "HIGH," and the "MIXB" line is "LOW," creating minimum attenuation for the MIXER A UNIT and maximum attenuation for the MIXER B UNIT.

### TWO-STAGE $\pi$ (PI) NETWORK ATTENUATOR EQUIVALENT DIAGRAM

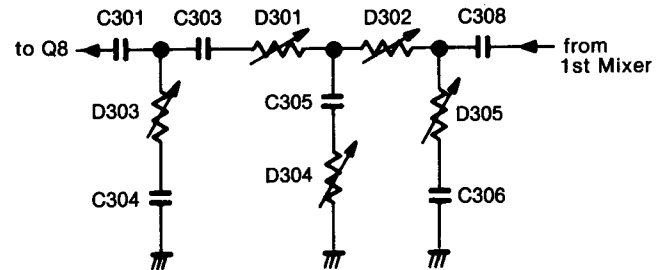

Fig. 4

When the "MIXA" level increases:

DIODES	IMPEDANCE
D301, D302	Decreases
D303, D304, D305	Increases

When the "MIXA" level decreases:

DIODES	IMPEDANCE
D301, D302	Increases
D303, D304, D305	Decreases

The 1st IF signal passes through a high isolation buffer amplifier (Q7, Q8), and is applied to the hybrid combiner (L24). The combined 1st IF signal is applied to the pair of MCF (Monolithic Crystal Filter; F11A) to suppress out-of-band signals. The signal is amplified at the IF amplifier (Q9), and is filtered at the MCF (F11B). The signal then enters the IF UNIT via J6 (IF UNIT: J13).

The 1st IF signal from the MIXER A UNIT is also applied to the scope amplifier Q10 via R308 and then to the SCOPE UNIT via J8.



#### 4-1-4 IF CIRCUITS (IF UNIT)

The 1st IF signal from the RF UNIT is converted to a 9 MHz 2nd IF signal at the 2nd mixer (IC14). IC14 is a DBM (Double Balanced Mixer).

##### 2ND IF SIGNAL IN EACH MODE

MODE	FREQUENCY (MHz)
SSB	9.0115
CW, RTTY	9.0106
AM, FM	9.0100

The 2nd LO signal (37.5 MHz) from the PLL-A UNIT via P6 is amplified at Q71 and applied to the 2nd mixer. The converted 2nd IF signal passes through D96 (D97 for transmitting) and is amplified at Q58. When operating FM, the signal is applied to Q43 via L28. Refer to Section 4-1-6 FM IF CIRCUIT for information on the path of the FM IF signal.

The signal output from Q58 passes through the noise blanker filter (F17), the noise blanker gate (D92~D95), and is then amplified at the 2nd IF amplifier (Q57). The signal enters one of the four 9 MHz filters (F15, F16, F19, F110) or bypasses them.

The signal from a 9 MHz filter passes through the impedance converter (Q74). The signal is mixed with the 3rd LO signal from the MAIN UNIT to be converted to a 455 kHz 3rd IF signal at IC12. R329 and R330, connected to the emitter of Q74, improve the temperature characteristics of the receiver gain. The 3rd IF signal is amplified at the 3rd IF amplifier (Q51) and passes through one of four 455 kHz filters (F12~F14, F18).

The signal from the 455 kHz filter passes through the impedance converter (Q47) and enters the MAIN UNIT via J9, pin 8 (IF UNIT: P3, pin 8). R157, connected to the emitter of Q47, improves the temperature characteristics of the receiver gain.

Dual-gate FETs are used on the 2nd and 3rd IF amplifiers (Q51, Q57). The 2nd gates of Q51 and Q57 are controlled by AGC bias voltage from the MAIN UNIT. The 9 MHz and 455 kHz filters are selected by control signals from the IF filter switching circuit. Refer to Section 4-2-17 IF FILTER SWITCHING CIRCUIT for information regarding filters and filter switch/operating mode combinations.

The 3rd IF signal is converted to a 10.695 MHz 4th IF signal at IC29 on the MAIN UNIT.

#### IF CIRCUIT

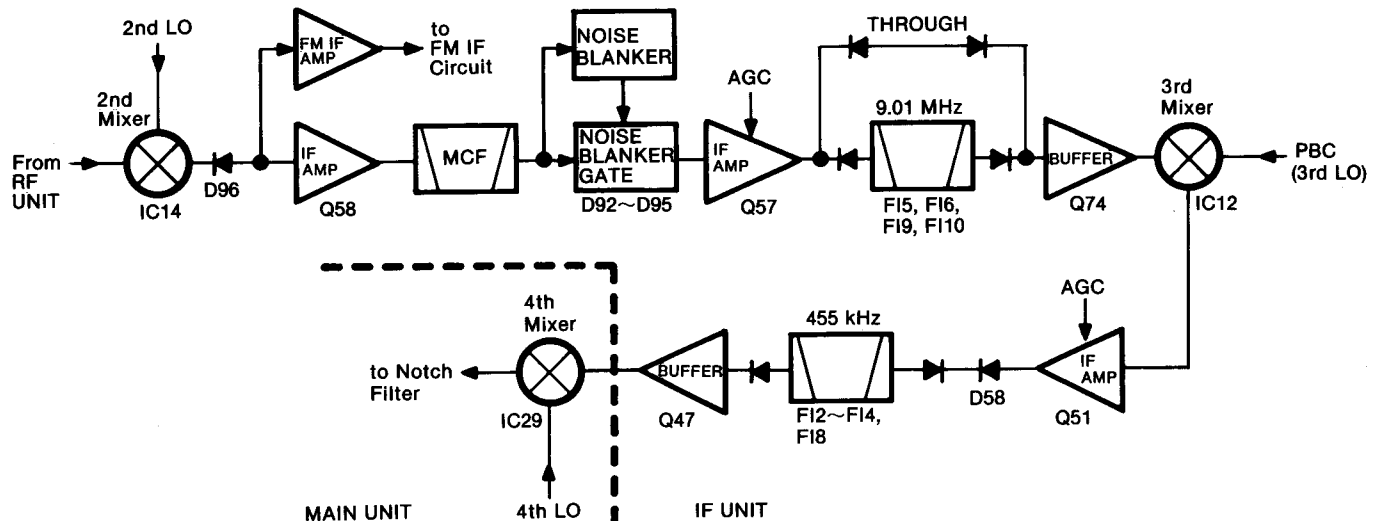

Fig. 5-

#### 4-1-5 NOISE BLANKER CIRCUITS (IF UNIT)

The IC-781 uses a noise trigger noise blanker circuit. Blank width can be adjusted for the "woodpecker noise" and its echo noise. A portion of the signal from F17 is amplified at the noise amplifier (Q59~Q61), which employs dual-gate FETs for wide AGC dynamic range. The signal is detected at the noise detector (D98, D99). A detected voltage is applied to the noise AGC circuit (Q63) and feedback to the noise amplifier as the AGC voltage.

The time constant of the noise AGC circuit is determined by R283 and C202. This AGC circuit does not operate for pulse-type noise. By applying pulse-type noise to the noise gate control circuit, normal signal strength reduces the gain of the noise amplifier.

The detected voltage from the noise detector (D98, D99) is applied to the two pulse amplifiers (Q62 and Q65). Q62 amplifies narrow-width pulses with the differentiating circuit (C201, R282). Q65 amplifies high level noise by using D100. D100 adds the threshold voltage to Q65.

The threshold level of each pulse amplifier is controlled by the [NB-LEVEL] control. When the detected voltage exceeds the threshold level, Q66 outputs a blanking signal to activate the noise blanker gate (D92~D95).

When the [NB-WIDE] switch is ON, the NB-wide circuits are activated. The NB-wide circuits consist of a pulse width stretch (Q68, Q69), gate drive (Q67) and blank pulse delay circuits. The blanking signal from Q66 enters the pulse width stretch circuit and turns Q67 ON and OFF. The stretch length of the pulse width stretch circuit is controlled by the [BLK-WIDTH] control via the "NBDL" line. The blank pulse delay circuit (Q70, D102) deactivates Q69 when receiving a narrow-width pulse noise.

Q64 cancels the noise blanker operation after 2 msec. (when NB-WIDE is OFF) or 15 msec. (when NB-WIDE is ON).

#### 4-1-6 FM IF CIRCUITS (IF UNIT)

The 9.0100 MHz 2nd IF signal amplified at the FM IF amplifier (Q43) passes through the limiter circuit (D43, D44) and then enters an FM IF IC chip (IC10, pin 16).

The 2nd IF signal is applied to the 3rd mixer section of IC10, and is mixed with the 3rd LO signal from the MAIN UNIT via P5 (MAIN UNIT: J14) to be converted to a 455 kHz 3rd IF signal. IC10 contains the 3rd mixer, limiter amplifier and quadrature detector circuit.

The 3rd IF signal from the 3rd mixer (IC10, pin 3) passes through the ceramic filter, FI1, where unwanted signals are filtered. The 3rd IF signal is then amplified at the limiter amplifier section (IC10, pin 5) and applied to the quadrature detector section to be demodulated into an AF signal.

AF signal output from pin 9 of IC10 is applied to the MAIN UNIT through the "FAF" signal line. The AF signal is also applied to the CM MODULE which outputs a center stop signal (CTL) for scanning operation.

The active filter section in IC10 amplifies noise components of frequencies of 20 kHz and above, and outputs the resulting signals from pin 11. Output signals are rectified by D41 and D42 using an FM noise squelch. The rectified voltage is applied to the MAIN UNIT through the "FSS" signal line.

When the [DATA] switch is ON, Q42 is turned OFF and C69 is disconnected from C70. Hence, the "FSS" signal line has a short time constant to provide rapid squelch open/close time.

This FM IF circuit also operates while transmitting. A leaked transmitter IF signal is picked up by the IF circuit to be demodulated into an FM monitor signal.

The FM IF signal, also applied to the IF circuits described in Section 4-1-3, enters the MAIN UNIT to provide a high dynamic range for the S-meter.

#### 4-1-7 NOTCH CIRCUITS (MAIN UNIT)

The 3rd IF signal from the IF UNIT via J9 pin 8 (IF UNIT: P3) is converted to the 10.695 MHz 4th IF signal at IC29. The resulting signal then passes through the T network bridge notch filter which uses a crystal unit (X5).

The notch oscillator (Q10, X1, D5) oscillates at 12.4 MHz. A voltage controlled by the [NOTCH] control is applied to the varactor diode (D5) to change the notch oscillator frequency.

#### FM IF CIRCUIT

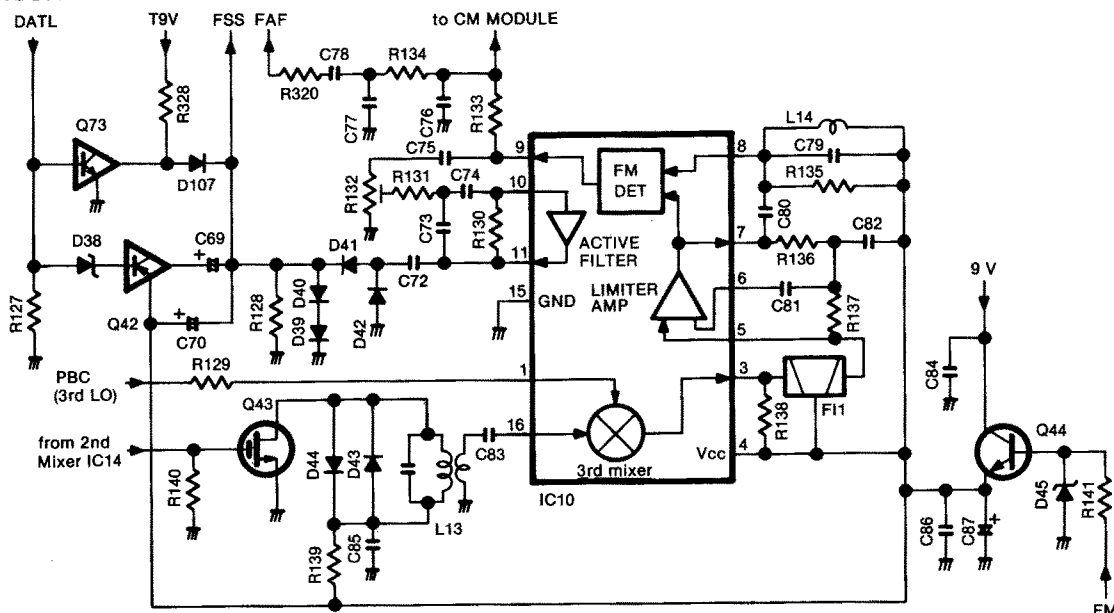

Fig. 6

The carrier frequency of an AM signal differs by 1.5 kHz from SSB or CW. In AM, therefore, Q12 and Q13 shift the notch oscillator frequency to fix the carrier frequency.

The notch oscillator signal is mixed with a 1.25 MHz PBT-2 signal at IC10, compensating for the IF frequency shifted for passband tuning of the 3rd IF signal. The resulting signal passes through the MCF (FI3), is buffer-amplified at Q11 and applied to IC29 as the 4th LO signal. The notch oscillator frequency is also applied to the BFO circuit compensating for the frequency shifted for the notch filter.

When the [NOTCH] switch is turned OFF, Q61 is turned ON and the 4th IF signal bypasses the notch filter (X5, C242~C244) through D46. In FM, the "FM" signal line becomes "HIGH," turning ON D46. Then, the FM IF signal used only for the S-meter and not for demodulation bypasses the notch filter.

The signal from the notch filter is applied to the MCF (FI4b) to filter leaked signal components from the LO signal. The signal is amplified at the IF amplifiers (Q44, Q45) which are controlled by AGC bias voltage. The signal is then applied to the demodulator circuit (IC28).

#### 4-1-8 TWIN PBT OSCILLATOR (MAIN UNIT)

The TWIN PBT oscillator circuit consists of two PLL circuits in the MAIN UNIT. A 12.5 MHz reference frequency oscillated at the PLL-A UNIT is buffer-amplified at Q1 in the MAIN UNIT, and is applied to these PLL circuits. These PLL circuits consist of a dual modulus prescaler (IC2, IC7) and a PLL IC (IC1, IC6).

A 142 MHz band signal is oscillated at PBT-1 circuit (IC1, IC2, Q2) and is divided by 80 at IC3 to obtain 1.7835 MHz. PBT-1 output, buffer-amplified at Q4, passes through the low-pass filter where high harmonic components are reduced. The resulting signal is mixed with the 12.5 MHz reference signal to produce a 10.7165 MHz signal.

The signal passes through the MCF (FI1), is amplified at Q5, and is then applied to IC5 and the PLL-A UNIT as the "PLOA" (PLL Local Oscillator A) signal. The signal amplified at Q5 is mixed with the PBT-2 output at IC5 to produce a 9.4665 MHz signal. The signal is applied to the MCF (FI2), amplified at Q6, and applied to the IF UNIT as the PBC (Pass Band Control) signal.

A 100 MHz signal oscillated at the PBT-2 circuit (IC6, IC7, Q7) is divided by 80 at IC8 to produce a 1.25 MHz signal. PBT-2 output, buffer-amplified at Q9, passes through the low-pass filter, and is then applied to IC5 and IC10. The output is mixed with the notch oscillator signal at IC10, and the resulting signal is applied to the 4th mixer (IC29) in the MAIN UNIT.

The PBT-1 and PBT-2 outputs are adjusted to within  $\pm 1.5$  kHz using the [TWIN PBT] controls. Changing the PBT-1 and PBT-2 frequencies electronically changes the center frequency of 9 MHz IF and 455 kHz IF filters respectively.

#### 4-1-9 BFO CIRCUIT (MAIN UNIT)

The BFO signal is used a balanced modulator, a product detector, an FM TX oscillator and a PLL circuit.

A 91 MHz signal oscillated at the BFO circuit (IC13, IC14, Q19) is divided by 20 at IC15, and divided by 10 at IC16 to obtain a 455 kHz signal. BFO output passes through the low-pass filter where high harmonic components are reduced.

The filtered 455 kHz signal is amplified at Q15 and used at the balanced modulator in the IF UNIT. The 455 kHz signal is also amplified at Q16 and applied to the PLL-A UNIT as the "PLOB" (PLL Local Oscillator B) signal.

To obtain a 10.695 MHz BFO signal, the filtered 455 kHz signal is mixed at IC9 with the 1.25 MHz CW pitch control signal and mixed again at IC11 with the 12.4 MHz notch oscillator signal.

To obtain a 9.010 MHz FTC (FM Transmit Carrier) signal, the filtered 455 kHz signal is mixed at IC12 with the 9.465 MHz FM TX oscillator signal.

The reference oscillator of the BFO PLL consists of Q18 and X2. The frequency is shifted with the [MODE] switches using D9~D11. In USB, the "USB" signal line becomes "HIGH," turning ON D10. The frequency is then adjusted with C106 to set the USB carrier point. In LSB, the "LSB" signal line becomes "HIGH," turning ON D11. The frequency is then adjusted with C107 to set the LSB carrier point.

#### 4-1-10 CW PITCH CONTROL CIRCUIT (MAIN UNIT)

The CW pitch control circuit outputs a 1.25 MHz signal. The frequency of this signal is variable in CW receiving and fixed at 1.25 MHz in CW transmitting and other modes.

In CW, the "CW" signal line becomes "HIGH," activating the CW pitch control oscillator (X3, Q24, D16) to control the BFO frequency.

The CW pitch control oscillator oscillates at 12.5 MHz. A voltage controlled by the [CW PITCH] control is applied to the varactor diode (D16) to change the CW pitch control oscillator frequency.

## MAIN UNIT FREQUENCY CONSTRUCTION

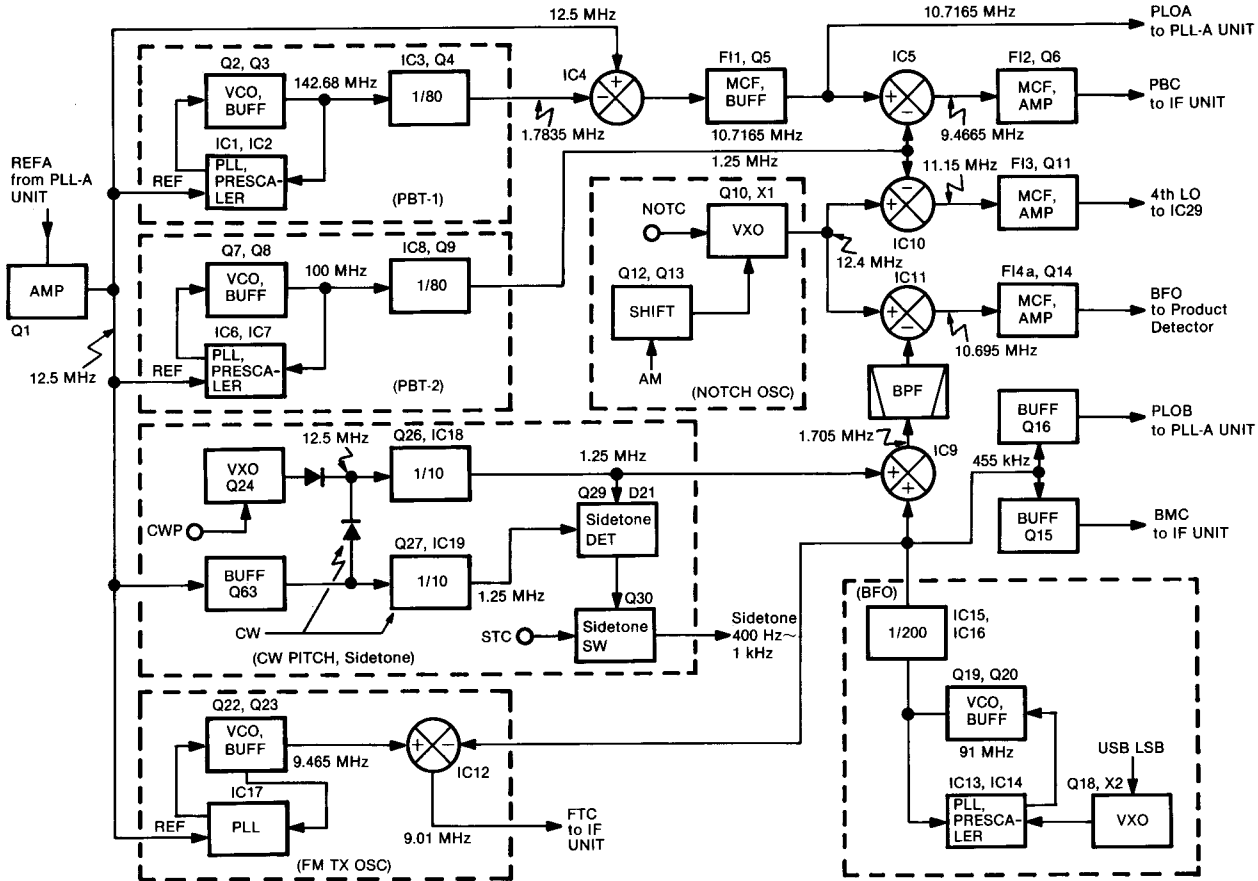

Fig. 7

The output signal, buffer-amplified at Q26, is divided by 10 at IC18, to obtain 1.25 MHz. The output from IC18 passes through the low-pass filter where high harmonic components are reduced. The resulting signal is mixed at IC9 with the BFO output signal. The signal which passes through the low-pass filter is also applied to the buffer amplifier Q29 to produce the CW sidetone.

In modes other than CW, the PLL-A UNIT 12.5 MHz reference signal, amplified at Q1, is amplified at Q63 and Q26. The signal is divided by 10 at IC18 and passes through the low-pass filter. The resulting signal is mixed at IC9 with the BFO output signal.

In CW, the 12.5 MHz reference signal is amplified at Q27, divided by 10 at IC19, and passes through the low-pass filter. The resulting 1.25 MHz signal and the signal amplified at Q29 are combined to generate a beat signal. The beat signal is detected at D21 to obtain the CW sidetone signal. The CW sidetone frequency can be adjusted with the [CW PITCH] control to provide "zero-in" operation.

The CW sidetone signal passes through the FET switch (Q30) controlled by the "STC" (Sidetone Control) signal line. The signal is then applied to the monitor amplifier (IC25 pin 2).

### 4-1-11 DEMODULATOR CIRCUITS (MAIN UNIT)

The 4th IF signal (SSB, CW and RTTY) from the notch circuit (IC29 through L60) is mixed with the BFO signal at the product detector (IC28) to demodulate the 4th IF signal into an AF signal. In AM and FM, Q42 is turned ON cutting off the diode switch (D6, D45) to deactivate the product detector. The detected signal passes through the AF input mode selector switch (IC27). IC27 pins 1 and 2 are connected inside the IC in CW (with [APF] OFF), SSB and RTTY.

When the [APF] switch is ON in CW, IC27 pins 10 and 11 are connected. The output signal from IC28 is applied to the APF (Audio Peak Filter) circuit (IC30b). The APF circuit, using an active bandpass filter, suppresses unwanted AF signals in CW and outputs the desired AF signal within a passband width of 100 Hz. The center frequency can be adjusted with the [APF] control between 400 Hz and 1000 Hz. The signal then passes through the AF input mode selector switch (IC27, pins 10 and 11).

The AM IF signal from the notch circuit passed through an impedance converter (Q43) is detected at D49 and D66, amplified at IC30a, and passes through the AF input mode selector switch (IC27, pins 8 and 9). The FM signal detected at IC10 in the IF UNIT is also applied to the AF input mode selector switch (IC27, pins 3 and 4).





The AGC bias voltage is applied to the differential amplifier (IC31) where the difference between the bias and reference voltages is detected. The resulting S-meter signal passes through the meter switching circuit (IC26), and is then applied to the multi-function meter.

#### 4-1-15 SQUELCH CIRCUIT (MAIN UNIT)

The S-meter signal from IC31 is applied to the comparator (IC32 pin 2) to be compared to a reference voltage controlled by the [SQL] control. This reference voltage is added to the S-meter voltage to indicate the squelch threshold level on the S-meter.

In FM, the noise squelch signal from the "FSS" signal line is applied to the comparator (IC32, pin 6) to be compared to the reference voltage controlled by the [SQL] control.

The [SQL] control employs a double variable resistor to obtain two relational reference voltages. When the S-meter or noise squelch signal is lower than the threshold level, the comparator turns "HIGH" to activate the squelch gate (Q40). This signal is applied to Q58, turning OFF the [RECEIVE] indicator and is then applied to Q57. Q57 outputs a signal via the "SQLR" line to control a tape recorder plugged into the [RECORDER REMOTE] jack.

## 4-2 TRANSMITTER CIRCUITS

### 4-2-1 MIC AMPLIFIER (MAIN UNIT)

Audio signals from the mic connector are amplified at the mic amplifier (Q301) in the AF VR UNIT. The signals pass through the [MIC GAIN] and [MIC TONE] controls, and then enter the MAIN UNIT via J16 pin 3. External modulation input from [ACC (1)] socket pin 4 and the [MOD-IN] jack is applied to J16 pins 2 and 6 respectively.

These signals are applied to the mic amplifier (IC23, pin 2), pass through the switching circuit (Q38), and are then applied to the balanced modulator (IF UNIT, IC11) via J9 pin 2 (IF UNIT: P3, pin 2). Q38 is turned OFF in CW, RTTY and FM.

In FM, the ALC meter reads the deviation. Output signals from IC23 pin 1 are applied to the IDC UNIT and IC23 pin 6. The signals are limiter-amplified at the IDC UNIT, and are then applied to the FM TX oscillator circuit. IC23 amplifies the signals for the deviation meter. Amplified signals are detected at D34 and D35, and are then applied to the ALC meter circuit.

When the [TONE] switch is turned ON, a subaudible tone is generated at the SUB TONE UNIT (EP8), buffer-amplified at Q37, and then applied to the FM TX oscillator circuit.

When the [DATA] switch is turned ON, the audio signals are muted at Q302 in the AF VR UNIT for error-free data communication.

### 4-2-2 RTTY SIGNAL GENERATOR (MAIN UNIT)

RTTY signals are generated with an audio signal and applied to the balanced modulator circuit in the IF UNIT.

IC20 consists of a reference oscillator, a divider and a sine wave converter. IC20 oscillates a 3.596 MHz signal with a crystal unit (X4) and outputs from pin 1 a 2120 Hz signal for MARK and a 2290 Hz signal for SPACE. Pins 8~13 on IC20 are for divided data input for the internal divider circuit. The output signal, amplified at Q31, passes through the switching circuit (Q35), and is then applied to the balanced modulator (IF UNIT, IC11). Q35 is turned OFF during receiving.

An RTTY keying signal is applied to Q34 via D29. The output signal is applied to IC21 to obtain the dividing data. When the RTTY MARK polarity switch (S1) is reversed, the output signal is inverted at Q33 and applied to IC21. 170 Hz, 425 Hz or 850 Hz shift frequencies can be selected with a plug, P1, on connector J17.

When the High tone/Low tone selector switch (S2) is turned to low tone, the dividing data is determined by the "9V" voltage line. This 9 V voltage turns Q32 ON. The "LOW" signal is applied to the CPU to change the BFO frequency for low tone operation.

#### RTTY SIGNAL GENERATOR OUTPUT FREQUENCIES:

TONE	MARK SPACE	SHIFT	OUTPUT FREQUENCY	IC20 INPUT PIN NUMBER					
				8	9	10	11	12	13
HIGH	MARK	—	2120 Hz	H	H	H	L	H	H
		170 Hz	2293 Hz	L	H	H	L	H	H
	SPACE	425 Hz	2554 Hz	H	L	H	L	H	H
		850 Hz	2957 Hz	L	L	H	L	H	H
LOW	MARK	—	1277 Hz	L	L	L	H	H	H
	SPACE	170 Hz	1459 Hz	H	L	L	H	H	H

### 4-2-3 FM TX OSCILLATOR (MAIN UNIT)

The transmitter has its own IF circuit. The FM TX oscillator circuit consists of PLL IC (IC17) and a VCO (Q22). This PLL circuit generates a 9.465 MHz signal. The 12.5 MHz reference frequency, buffer-amplified at Q1, is applied to this PLL circuit via C144 as a reference frequency.

IDC UNIT output signals (microphone AF signals) and Q37 (subaudible tone signals) are applied to the VCO circuit to generate an FM signal. The FM signal, buffer-amplified at Q23, is mixed with the BFO oscillator signal at the mixer circuit (IC12), creating a 9.010 MHz IF signal for transmitting.

The resulting signal passes through the bandpass filter (L31, L35, C102) and is then applied to the IF UNIT via J10. Q17 activates the mixer circuit during FM transmitting using the "T9V" voltage and "FM" signal lines.

### 4-2-4 BALANCED MODULATOR (IF UNIT)

Output signals from the mic amplifier or RTTY signal generator enter the IF UNIT and are applied to the balanced modulator circuit (IC11) to be converted to a 455 kHz IF signal. The BMC (Balanced Modulator Carrier) signal, buffer-amplified at Q15 in the MAIN UNIT, is applied to IC11 pin 7 as a carrier signal. IC11 outputs a double sideband signal which is buffer-amplified at Q46 and passes through a 455 kHz filter to create an SSB signal.

R142 and R145 adjust the balance level of IC11 for maximum carrier suppression. In AM and CW, Q45 and R144 upset the balance to create a carrier signal.

### COMPRESSOR CIRCUIT

### 4-2-5 COMPRESSOR CIRCUIT (IF UNIT)

The output signal from the 455 kHz filter passes through the impedance converter (Q50) and then through D59 or D60. When the [COMP] switch is ON, or CW or RTTY is selected, the signal amplified at Q53 passes through the diode limiter (D65, D66), and is amplified at Q56 (dual-gate FET). The gain of Q56 is controlled by the 2nd gate using the [DRIVE] control. When the [COMP] switch is OFF in SSB, the signal bypasses the above circuits through D60 and D61.

### 4-2-6 IF CIRCUITS (IF AND RF UNITS)

An amplified or bypassed signal from the compressor circuit is mixed with the PBC signal to be converted to a 9 MHz IF signal at IC13. The 9 MHz IF signal passes through a 9 MHz filter where unwanted sideband signals are removed. The resulting signal is amplified at Q39, and is then mixed with the 2nd LO signal to be converted to a 46.5115 MHz IF signal at IC14. IC14 is used in receiving and transmitting. The FM signal from the MAIN UNIT is amplified at Q32 and is then applied to IC14.

The IF amplifiers (Q32, Q39) are dual-gate FETs. The 2nd gates of Q32 and Q39 are controlled by ALC bias voltage from the ALC circuit.

The 46.5115 MHz IF signal enters the RF UNIT, passes through the MCF (F11B), and is then amplified at Q23. The 2nd gate of Q23 is also controlled by the ALC bias voltage. The amplified signal is converted to the displayed frequency at the balanced mixer (Q24, Q25).

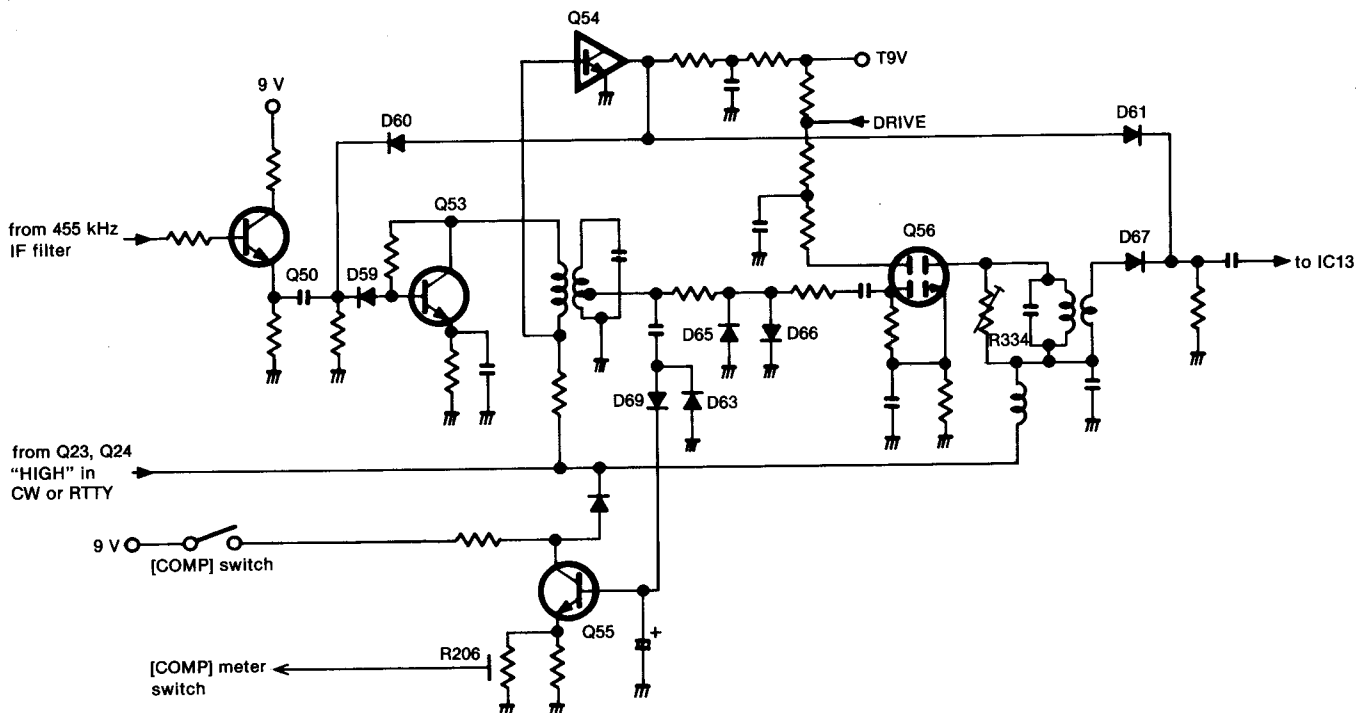

Fig. 9

## 4-2-7 RF CIRCUITS (RF AND PA UNITS)

The converted signal from Q24 and Q25 is applied to the 30 MHz low-pass filter where the unwanted LO signal emission is reduced. The converted signal is then amplified at Q21. The bias voltage of Q21 (2nd gate) is controlled by the [RF PWR] control. The amplified signal passes through the X-VERTER switching circuit (D49, D50), is amplified at Q20, and is then applied to the PA UNIT via J13. Output level from the RF UNIT is +6 dBm (maximum). D50 improves the temperature characteristics of Q20.

When the "TRV8" signal line becomes "HIGH," Q16 is turned ON. The signal from Q21 is applied to the [X-VERTER] jack via D49 and D47 for use with an external transverter. The maximum output level is -20 dBm.

C172~C174 and L134 form a high-pass filter to prevent the re-application of strong signals below 1.6 MHz, such as those from a broadcasting station.

Incoming signals from the RF UNIT are amplified at the predriver (Q1), the driver (Q2, Q3) and the power amplifier (Q4, Q5) to obtain a stable 150 W RF output power. The predriver is a class A amplifier with a Vcc of 15 V. The driver and the power amplifier are class AB push-pull amplifiers with a Vcc of approx. 28 V. A stable bias voltage is applied to the predriver, driver and power amplifier. Q11, D1 and D3 supplies a bias voltage to the driver. Q6~Q8 and D2 supply a bias voltage to the power amplifier.

A 0.012 Ω resistor (R34), inserted in the 28 V Vcc line, is provided for the Ic meter. A voltage generated at both terminals of R34 is applied to the IF UNIT via the "IC +" and "IC -" signal line.

Thermal switches S1 and S2 detect the temperature of Q4 and the REG UNIT, and control the cooling fan speed.

TEMPERATURE °C (°F)		Below 50 (122)	50~80 (122~176)	Above 80 (176)
THERMAL SWITCH	S1	OFF	OFF	ON
	S2	OFF	ON	ON
COOLING FAN SPEED	RECEIVE	STOP	LOW	HIGH
	TRANSMIT	LOW		HIGH

## 4-2-8 FILTER UNIT

The FILTER UNIT has seven Chebyshev low-pass filters. The signal from the PA UNIT, applied to one of the low-pass filters depending on the transmit frequency range, suppresses high harmonic components.

The filter switching voltage, obtained at the LOGIC-B UNIT, passes through the TUNER UNIT and is applied to the FILTER UNIT via P1.

## FREQUENCIES AND APPROPRIATE FILTERS

FILTER	FREQUENCY RANGE (MHz)
1.9 MHz	Below 2
3.5 MHz	2~ 4
7 MHz	4~ 8
10 MHz	8~11
14 MHz	11~15
21 MHz	15~22
28 MHz	22~30

The filtered signal passes through the SWR detector circuit (L16) and is then applied to the CONNECTOR 2 UNIT. The forward signal from L16 is detected at D9 and applied to the IF UNIT as the "FOR" voltage. The reflection signal from L16 is detected at D8 and applied to the IF UNIT as the "REF" voltage.

## SWR DETECTOR CIRCUIT

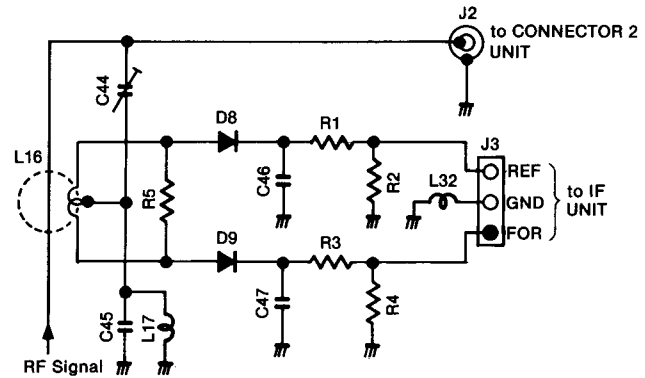

Fig. 10

## 4-2-9 ANTENNA SWITCHING CIRCUIT (CONNECTOR 2 UNIT)

The RF signal from the FILTER UNIT passes through a diode switch (D101) and the TUNER UNIT, and is then applied to the antenna connector. A 200 mA bias current is supplied from Q101 and Q102 to D101 to prevent rectification of the RF signal.

## 4-2-10 ALC CIRCUIT (IF UNIT)

The "FOR" voltage from the FILTER UNIT is applied to IC4 pin 6 and IC5 pin 3. The "POIF" voltage controlled by the [RF PWR] control is also applied to IC4 pin 5 as the reference voltage.

When the "FOR" voltage exceeds the "POIF" voltage, IC4 controls the IF amplifiers to reduce the output power until the "FOR" and "POIF" voltages are equalized.

IC4 pin 7 outputs negative voltage, supplying a minus voltage to a time constant line via Q35 and Q36. The signal which passes through the time constant line is applied to an impedance converter (Q33, Q34) to control the ALC bias voltage.

Q30 supplies an ALC reference voltage to the ALC bias voltage line. When receiving, Q29 is turned ON to cut off the ALC reference voltage. A time constant (R91, R92, C38), connected to the collector of Q29, provides for slow attack output power—preventing the key click noise.

An external ALC input from the [ALC] jack passes through the [ALC-LEVEL] pot and is applied to Q37. ALC operation is identical to that of the internal ALC.

In AM, the AM ALC circuit is activated to control the carrier level. Output from the Po meter amplifier (IC5 pin 1) is applied to IC5 which employs an averaging ALC amplifier. The resulting signal is applied to Q45 to obtain a stable carrier level.

#### 4-2-11 APC CIRCUITS (IF UNIT)

The APC circuits protect the final transistors from high SWR and excessive current. The "REF" voltage from the FILTER UNIT is applied to IC4 pin 3. The amplified signal is applied to IC6 pin 2. The reference voltage, determined by R59 and R60, is applied to IC6 pin 3. The output voltage from IC6 pin 1 is applied to the ALC time constant line via D14 to reduce the output power.

The output voltage of the Ic meter amplifier (IC3) is also applied to IC6 pin 2 to prevent excessive current.

#### 4-2-12 CW KEYING CIRCUIT (IF UNIT)

A keying signal from the [ELEC-KEY] jack enters the electronic keyer IC (NB SW UNIT, IC101), and is applied to Q8 via the "KEY" signal line. A keying signal from the [KEY] jack is also applied to Q8.

When the CW key is closed, the "KEY" signal line becomes "LOW." IC2 pin 11 outputs a "LOW" signal to the MAIN UNIT as the "STC" signal. IC2 pin 10 outputs a "LOW" signal to the ALC circuit and Q5. Q5 is turned OFF, and Q45 is turned ON to create a carrier signal at the balanced modulator (IC11).

#### ALC CIRCUIT

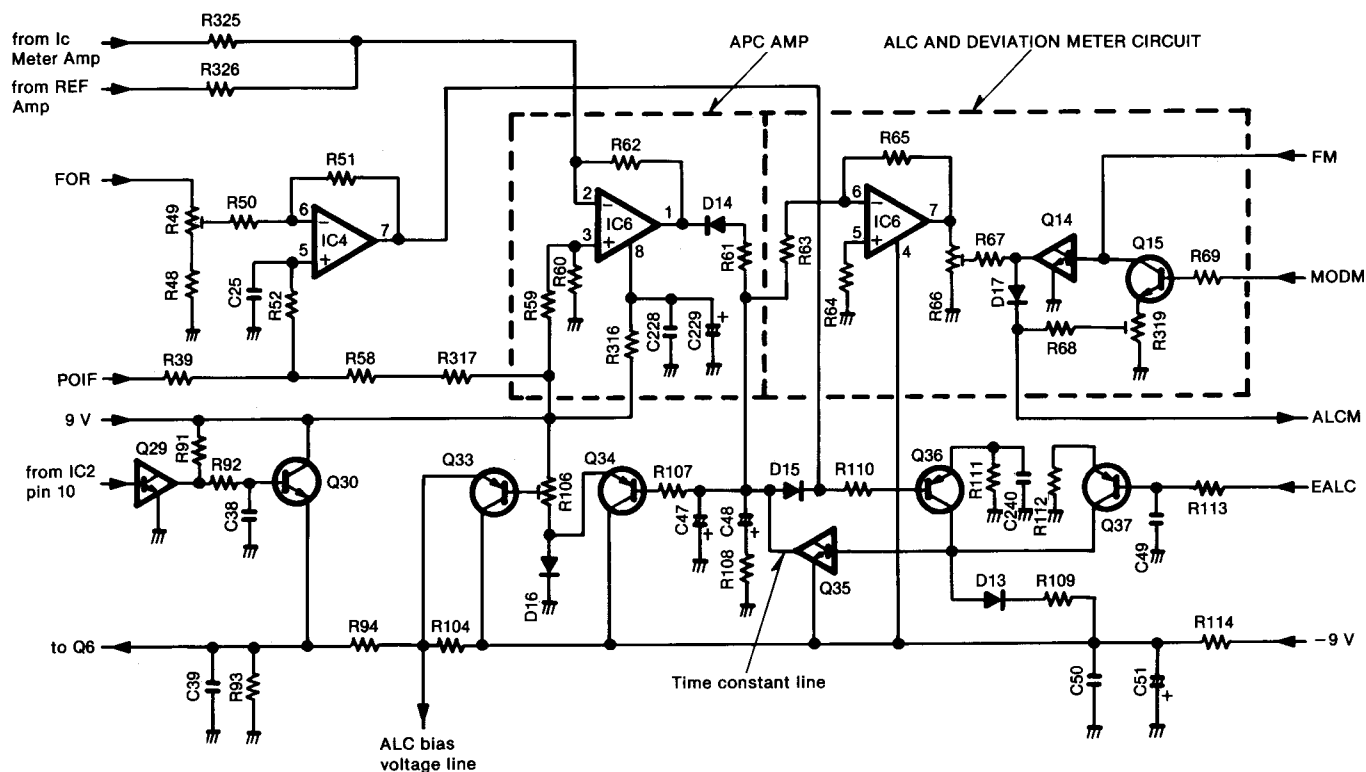

Fig. 11

### 4-2-13 MONITOR CIRCUIT (IF AND MAIN UNITS)

A portion of the 9 MHz IF signal from Q39 in the IF UNIT is amplified at Q38 and converted to a 455 kHz IF monitor signal at IC9. The signal is demodulated at IC8 and applied to the monitor selector switch (IC26 pin 2) in the MAIN UNIT as the "MAF" signal.

IC26 pin 13 receives the "MONS" signal to turn ON the selector switch. Hence, the monitor signal, passed through the monitor switch, is applied to the monitor amplifier (IC25 pin 2).

In CW, the CW sidetone signal from the CW pitch oscillator is applied to the monitor amplifier. The "MONS" signal is cut off at the selector switch by Q39.

In FM, the monitor signal, demodulated at IC10 in the IF UNIT, passes through the monitor selector switch (IC26 pin 10). The signal is then applied to the monitor amplifier (IC25 pin 2).

### 4-2-14 TRANSMITTER METER CIRCUITS (IF UNIT)

#### (1) Po meter

The "FOR" voltage from the FILTER UNIT is applied to the Po meter amplifier (IC5 pin 3), and is then applied to the meter function switch (S109 in the NB SW UNIT). D11 and C19 are used for peak power measurement.

#### (2) Ic meter

The "IC+" and "IC-" voltages, generated in the PA UNIT, are applied to a differential amplifier IC3. The resulting signal is applied to the meter function switch.

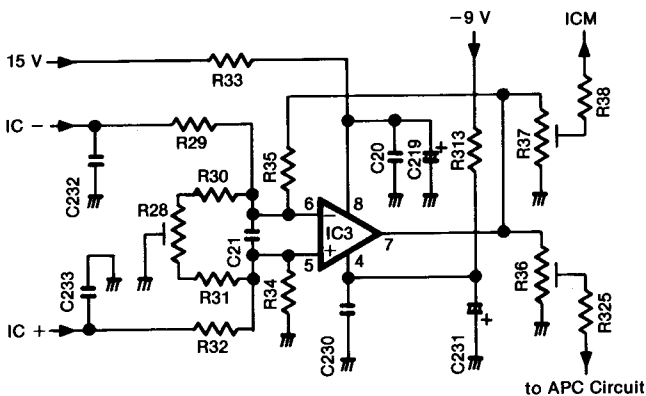

Fig. 12

#### (3) ALC meter

A voltage from the ALC time constant line is applied to the ALC meter amplifier (IC6 pin 6), and is then applied to the meter function switch.

In FM, the "FM" signal line becomes "HIGH," turning ON Q14. The ALC meter signal is then cut off, and the deviation meter signal from the MAIN UNIT is amplified at Q15, and is also applied to the meter function switch as the deviation meter signal.

#### (4) COMP meter

A portion of the output from the compressor amplifier (Q53) is detected at D63 and D64, amplified at Q55, and applied to the meter function switch.

#### (5) SWR meter

The "FOR" voltage, amplified at the Po meter amplifier, is applied to the SWR MODULE. The "REF" voltage, amplified at IC4, is also applied to the SWR MODULE. The SWR MODULE outputs a signal according to the ratio of "FOR" to "REF" voltage. The signal is applied to the meter function switch.

### 4-2-15 METER SWITCHING CIRCUIT (MAIN UNIT)

The transmitter meter signal, selected with the meter function switch, is applied to the meter switching circuit (IC26). The S-meter signal from IC31 is also applied to IC26. The meter signal is selected with the "T9V" and "R9V" voltage lines.

### 4-2-16 T/R SWITCHING CIRCUIT (IF UNIT)

When the PTT or [TRANSMIT/RECEIVE] switch is set to transmit, IC1 pin 8 and IC1 pin 6 are "LOW." At this time, Q9 turns ON, and 0 V are present on the "R9V" line. Q11 turns OFF, and there are 9 V present on the "T9V" line.

#### T/R SWITCHING CIRCUIT

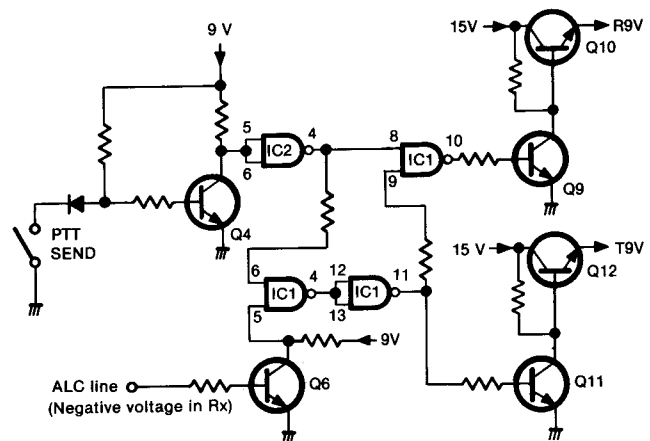

A	B	Y
L	L	H
L	H	H
H	L	H
H	H	L

Fig. 13

## T9V TIMING CHART

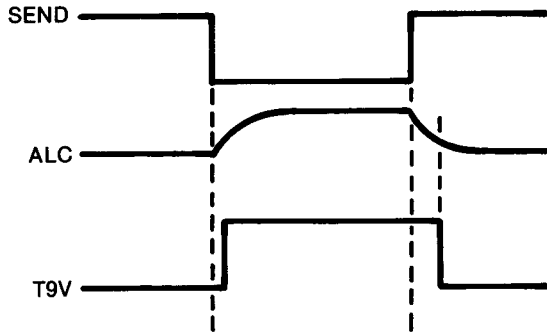

Fig. 14

When the PTT or [TRANSMIT/RECEIVE] switch is set to receive, IC1 pin 8 and IC1 pin 6 are "HIGH." IC1 pin 5 is "HIGH" after the "ALC" line becomes "LOW." At this time, Q9 turns OFF, and 9 V are present on the "R9V" line. Q11 turns ON, and there are 0 V present on the "T9V" line.

## IF FILTER SWITCHING CIRCUIT

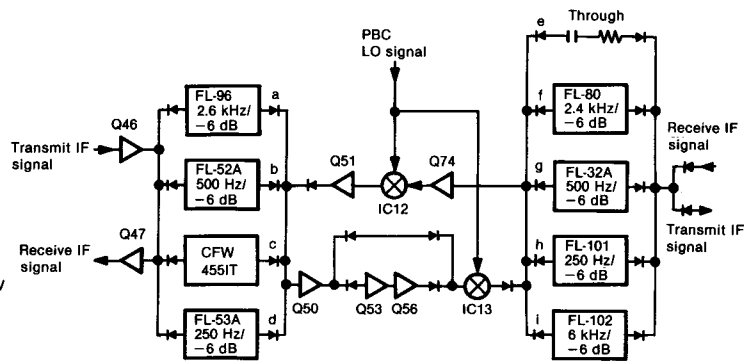
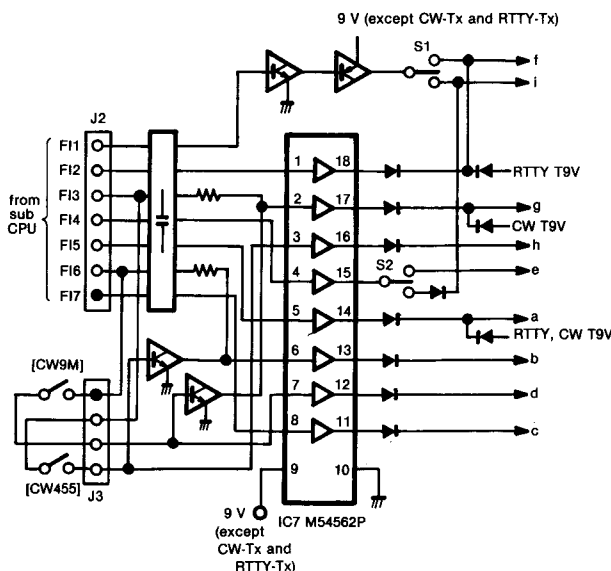

Fig. 15

## 4-3 PLL CIRCUITS

### 4-3-1 GENERAL DESCRIPTION

Two PLL circuits provide Dual Watch operation. These circuits are incorporated in the PLL-A and PLL-B UNITS.

Each PLL UNIT generates a 1st LO signal (46.6115 ~76.5115 MHz variable) used in the RF UNIT. PLL-A UNIT generates a 2nd LO signal (37.5 MHz fixed) used in the IF UNIT. The 1st LO signal contains BFO shift and PBT-1 shift frequencies which are generated in the MAIN UNIT.

This section mainly describes the PLL-A UNIT, which has circuitry that is similar to the PLL-B UNIT.

### 4-2-17 MUTE CIRCUIT (IF UNIT)

The mute circuit prevents clicking when PLL data or the operating mode are changed. When PLL data are changed, the "MUTE" signal (or "LMUT" when the operating mode is changed) is applied to the mute detector circuit (Q48, Q49). The mute detector circuit outputs the mute signal to the IF amplifier Q51 to cut off the receiver IF signal. The mute signal is also applied to the squelch gate (Q40) to cut off the AF circuit.

### 4-2-18 IF FILTER SWITCHING CIRCUIT

The IC-781 has four 9 MHz IF filters (plus one bypass circuit) and four 455 kHz IF filters. IF filter combinations are selected with sub CPU output ("FI1"~"FI7") depending on the operating mode. IC7 is a voltage buffer that turns ON the filter switching diodes.

### 4-3-2 REFERENCE OSCILLATOR CIRCUIT

The reference oscillator signal is used for the PLL-A and B UNITS, the MAIN UNIT PBT PLL and the BFO PLL. Thus, the reference oscillator stability determines the transceiver's frequency stability. Therefore, a constant temperature oven crystal unit with calibration control (CR-228) is used to maintain frequency stability within  $\pm 0.25$  ppm ( $-30^{\circ}\text{C} \sim +60^{\circ}\text{C}$ ;  $-22^{\circ}\text{F} \sim +140^{\circ}\text{F}$ ).

### 4-3-3 2ND LO CIRCUIT

A 12.5 MHz signal oscillated at X1 (CR-228) is multiplied by 3 at Q33. The resulting 37.5 MHz signal is applied to the IF UNIT via J5 (IF UNIT: P6).

#### 4-3-4 MAIN LOOP

The main loop uses a pulse swallow counter system that generates 46.6115~76.5115 MHz signals in 500 kHz steps. Because the sub loop produces 10 Hz steps, the PLL produces a 30 MHz frequency range in 10 Hz steps.

The oscillated signal at one of the four VCOs (Q2, Q3, Q13, Q14; see Section 4-3-5 for details) is amplified at Q6 and Q45. The signal is mixed with the sub loop output ( $f_{LO}$ : 42.0115~42.51149 MHz) at IC4 and filtered at the low-pass filter (L50~L53, C136~C142). Q21 is an isolator which ensures that the mixer input does not affect the VCO output.

The mixed signal is amplified at Q19 and Q20 and is then filtered at one of three filters. The filter is selected by the "V1A"~"V4A" signals from the LOGIC-A UNIT. The filtered signal, amplified at Q18, is then applied to the prescaler (IC10, IC11 in EP2). The signal, divided by 3 or 4, is applied to the PLL IC (IC2).

IC2 contains a phase detector, a programmable divider and a modulus controller for the dividing ratio in the IC chip. The phase of the divided signal at IC10, detected at IC2 using a reference frequency ( $f_{REF}$ ) of 500 kHz, is then output from pins 15 and 16. The 500 kHz frequency is obtained from the reference oscillator (X1). 12.5 MHz oscillated at X1, is divided by 5 at IC8 and divided by 5 at the programmable divider section of IC2.

The phase detected signal is then converted to the lock voltage at the loop filter (IC3; see Section 4-3-6 for details), and applied to the VCO. Thus, the VCO output (PLL output) is locked to produce stable oscillation.

The PLL oscillation frequency is obtained with the following calculation:

$$f_V = f_{LO} + N_T \times f_{REF}$$

- $f_V$  : Main loop output
- $f_{LO}$  : Sub loop output
- $N_T$  : Dividing ratio from the LOGIC-A UNIT
- $f_{REF}$  : Reference frequency (500 kHz)

#### 4-3-5 VCO CIRCUIT

The transceiver's C/N ratio is determined by the VCO and the loop filter. Four VCO circuits keep the low noise and reduce spurious emissions. Q4, Q5, Q15 and Q16 are VCO switches which select the operating VCO with "VA1"~"VA4" lines. The "VA1"~"VA4" lines are also used for the bandpass filter in the PLL circuits.

#### 4-3-6 LOOP FILTER

The loop filter converts a pulse-type signal to a DC signal with no ripple. If ripple is present, VCO noise or spurious signals increase. However, when ripple is reduced, PLL lock-up time increases. To reduce ripple and create rapid lock-up time, the active filter is used as a loop filter. Rapid lock-up speed is made by R3, R5/C15 and R4, R6/C17. Ripple is reduced by R8/C15 and R7/C17. When the frequency is greatly changed, D24~D27 speed up lock-up time.

#### 4-3-7 MARKER CIRCUIT

A 500 kHz signal is output from IC2 pin 13. The signal is divided by 4 at IC1 and then divided by 5 at IC9 to obtain a 25 kHz signal. The 25 kHz signal is amplified at Q44 and applied to the RF UNIT via P10 (RF UNIT: J5).

#### 4-3-8 SUB LOOP

The sub loop uses a DDS (Direct Digital Synthesizer) system that generates 42.0115~42.51149 MHz signals in 10 Hz steps. The BFO shift frequency and the PBT-1 shift frequency are mixed in the sub loop for Passband Tuning operation.

The oscillated signal at the VCO (Q24) is buffer-amplified at Q25 and mixed with the BFO/PBT-1 shift signal ( $f_{LO1}$ : 41.5115 MHz  $\pm$  shift frequency). The resulting signal passes through the low-pass filter, is amplified at Q30 and Q31, and is then applied to the DDS-A UNIT.

The output pulse-type signal from the DDS-A UNIT passes through the loop filter (R88, R89, C158) where it is converted into a DC signal (lock voltage). The lock voltage is applied to the VCO to lock the oscillating frequency.

#### 4-3-9 BFO, PBT SHIFT SIGNAL

The PBT-1 PLL output (PLOA: 10.7165 MHz  $\pm$  1.5 kHz) from the MAIN UNIT enters the PLL-A UNIT via J9 (MAIN UNIT: J14). The signal passes through the isolator (Q42) and is applied to the mixer (IC7). A reference oscillator signal from X1 is divided by 2 at IC8 and then multiplied by 5 at Q37 and Q38. The resulting 31.25 MHz signal is also applied to IC7 to produce the PBT-1 shift frequency (41.9665 MHz  $\pm$  1.5 kHz).

The PBT-1 shift frequency output from IC7 pin 2 is filtered at F12, amplified at Q36, and then applied to the mixer (IC6) to be mixed with the BFO shift frequency.



The BFO PLL output (PLOB: 455 kHz  $\pm$  mode shift frequency) from the MAIN UNIT enters the PLL-A UNIT via J6 (MAIN UNIT: J12). The signal passes through the isolator (Q34) and is mixed with the PBT-1

shift frequency at IC6. The resulting signal ( $f_{LO1}$ : 41.5115 MHz  $\pm$  shift frequency) is filtered at F1 and amplified at Q35. The amplified signal is applied to both the sub loop mixer (IC5) and the PLL-B UNIT.

### PLL CIRCUITS: BLOCK DIAGRAM

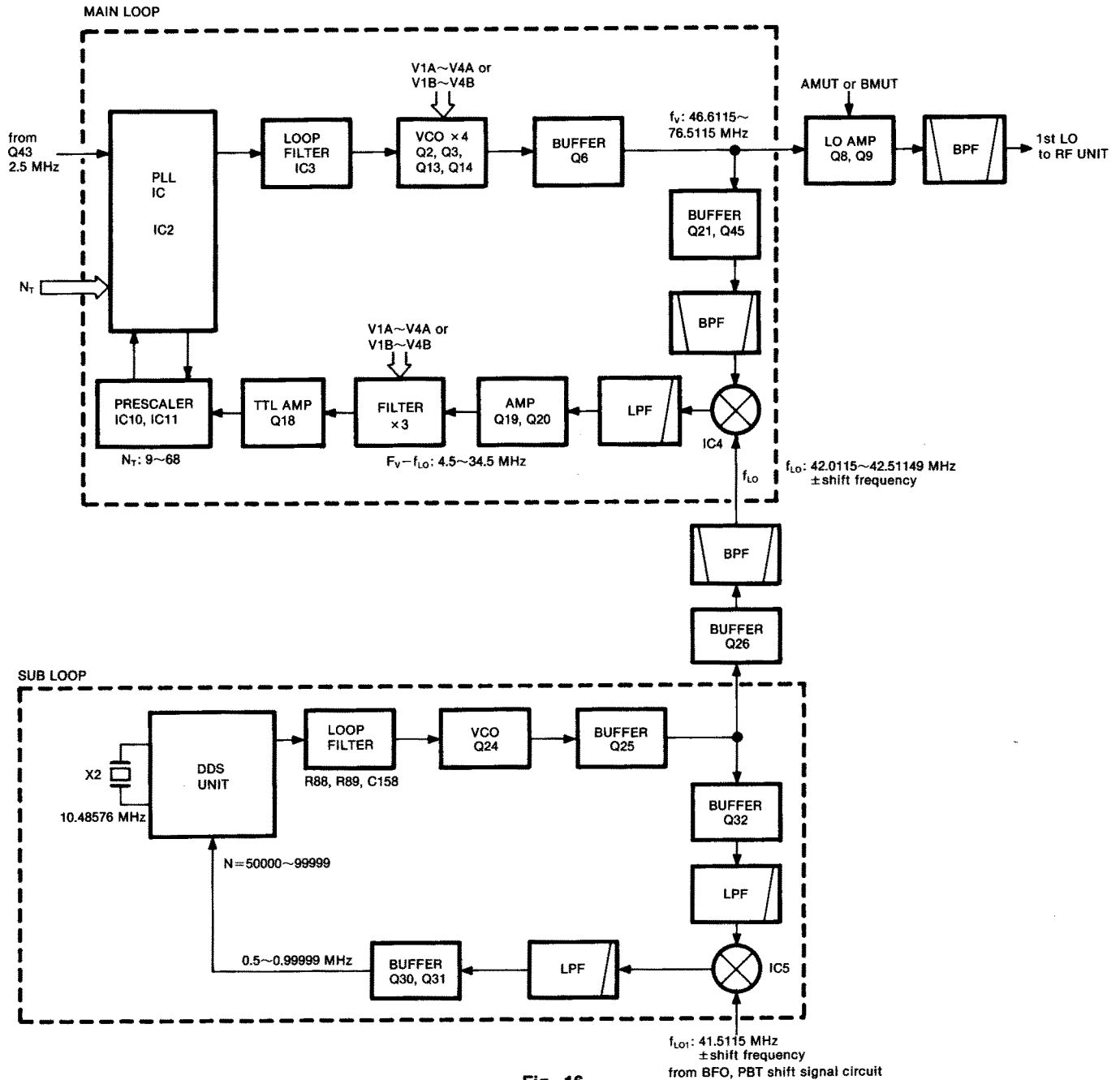

Fig. 16

### 4-3-10 MUTE CIRCUIT

When the main loop or the sub loop is unlocked, the "LD" terminal (IC2, pin 7 or "LD" on the DDS UNIT) becomes "LOW," turning Q22 ON. When Q22 is ON, Q22 outputs "HIGH" as the "AMUT" signal (PLL-B UNIT: "BMUT"). The "AMUT" signal turns Q7 and Q17 ON, deactivating the PLL output buffer amplifier (Q8 and Q9). The "AMUT" signal is also applied to the RF UNIT via the LOGIC-B UNIT, creating a Pi network attenuator (D301~D305) to maximize attenuation.

When transmitting or when Dual Watch is OFF, the PLL-B UNIT is deactivated by the "DWMU" signal. The "DWMU" signal coming from the MODE SW UNIT passes through the LOGIC-B UNIT and enters the PLL-B UNIT via P3, pin 1. The "DWMU" signal deactivates the PLL output buffer amplifier (Q8 and Q9), and cuts off the VCO switching signal ("V1B" ~ "V4B") at the LOGIC-A UNIT.

## 4-4 LOGIC CIRCUITS

The LOGIC UNIT mainly consists of two CPUs, five input expanders and three I/O expanders. Two CPUs, an 8-bit main CPU and a 4-bit sub CPU, control most functions including the CRT display.

The input and output ports are displayed on the block diagram on the next page.

### 4-4-1 MODE INPUT DATA

Input expander IC501 pins 15~17 receive the following data:

MODE	PIN NO. (PORT NO.)		
	15 (P60)	16 (P61)	17 (P62)
LSB	LOW	HIGH	HIGH
USB	HIGH	LOW	HIGH
AM	LOW	LOW	HIGH
CW	HIGH	HIGH	LOW
RTTY	LOW	HIGH	LOW
FM	HIGH	LOW	LOW

### 4-4-2 SCAN SPEED AND DELAY

IC14 pins 8 and 9 are scan speed and delay input ports which receive scan clock signals. A scan speed clock signal is generated at IC16 (pins 4~6 and 8~10) and a scan delay clock signal is generated at IC16 (pins 1~3, 11~13) on the LOGIC-B UNIT. Clock speed is determined by the [SCAN SPEED] control via the "SCS1 and SCS2" lines and the [SCAN DELAY] control via the "SCD1 and SCD2" lines.

### 4-4-3 BAND SELECTION DATA

To select the correct bandpass filter, the low-pass filter and VCOs in the PLL-A and B UNITS, I/O expander (IC1) in the LOGIC-A UNIT outputs the following data:

FREQUENCY (MHz)	BPF	LPF	VCO
0.1~ 0.499	B1	1.9 M	V1
0.5~ 1.599	B2		
1.6~ 1.999	B3		
2.0~ 2.999	B4	3.5 M	
3.0~ 3.999	B5		
4.0~ 5.999	B6	7 M	
6.0~ 7.999	B7		
8.0~10.999	B8	10 M	V2
11.0~14.999	B9	14 M	
15.0~21.999	B10	21 M	V3
22.0~30.0	B11	28 M	V4

### 4-4-4 CRTC UNIT

The CRTC (CRT Controller) UNIT converts the logic circuit data (DB0~DB7, A0~A3) into the composite picture signal.

IC1 generates R, G, B, L/d signals with data from the logic circuits. These signals are converted to the composite picture signal at IC2 and buffer-amplified at Q1. The amplified signal passes through the low-pass filter and is then applied to the DISPLAY UNIT via P5.

The composite picture signal, amplified by Q9 in the LOGIC-A UNIT, is applied to the [DATA-IN] socket as video output for a TV set.

### CRTC UNIT

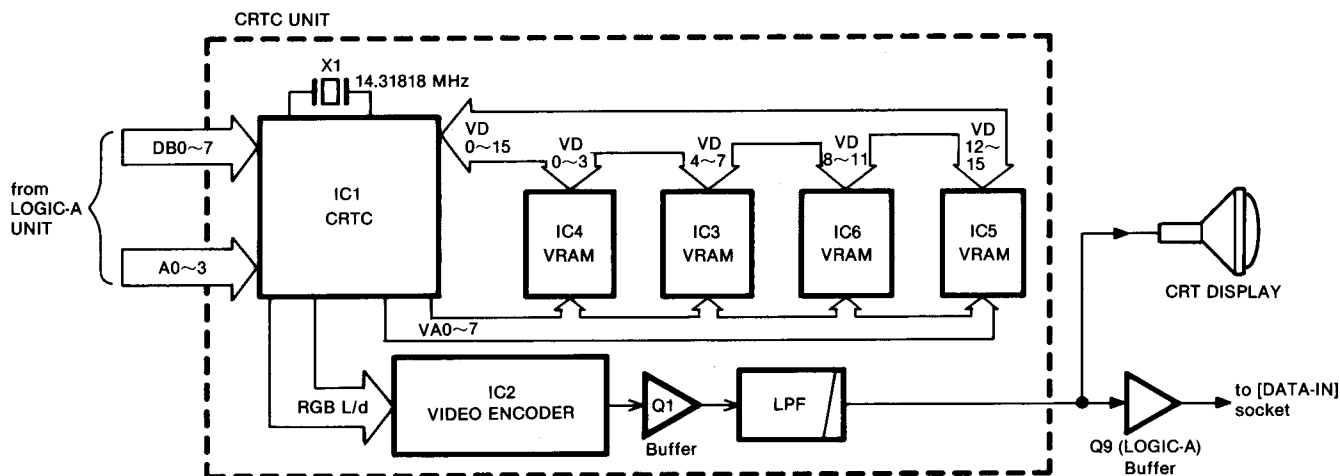

Fig. 17

# LOGIC CIRCUITS: BLOCK DIAGRAM

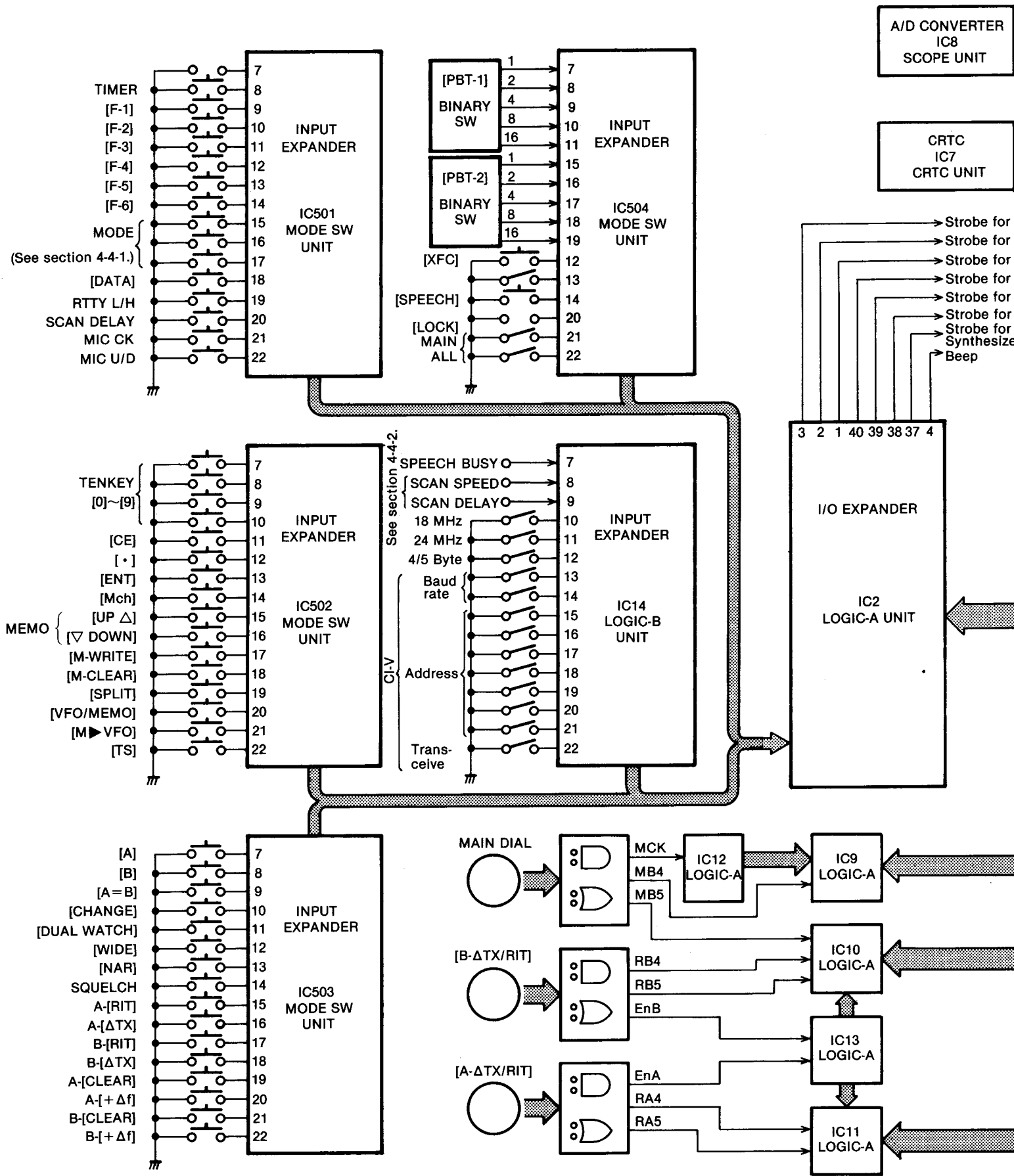
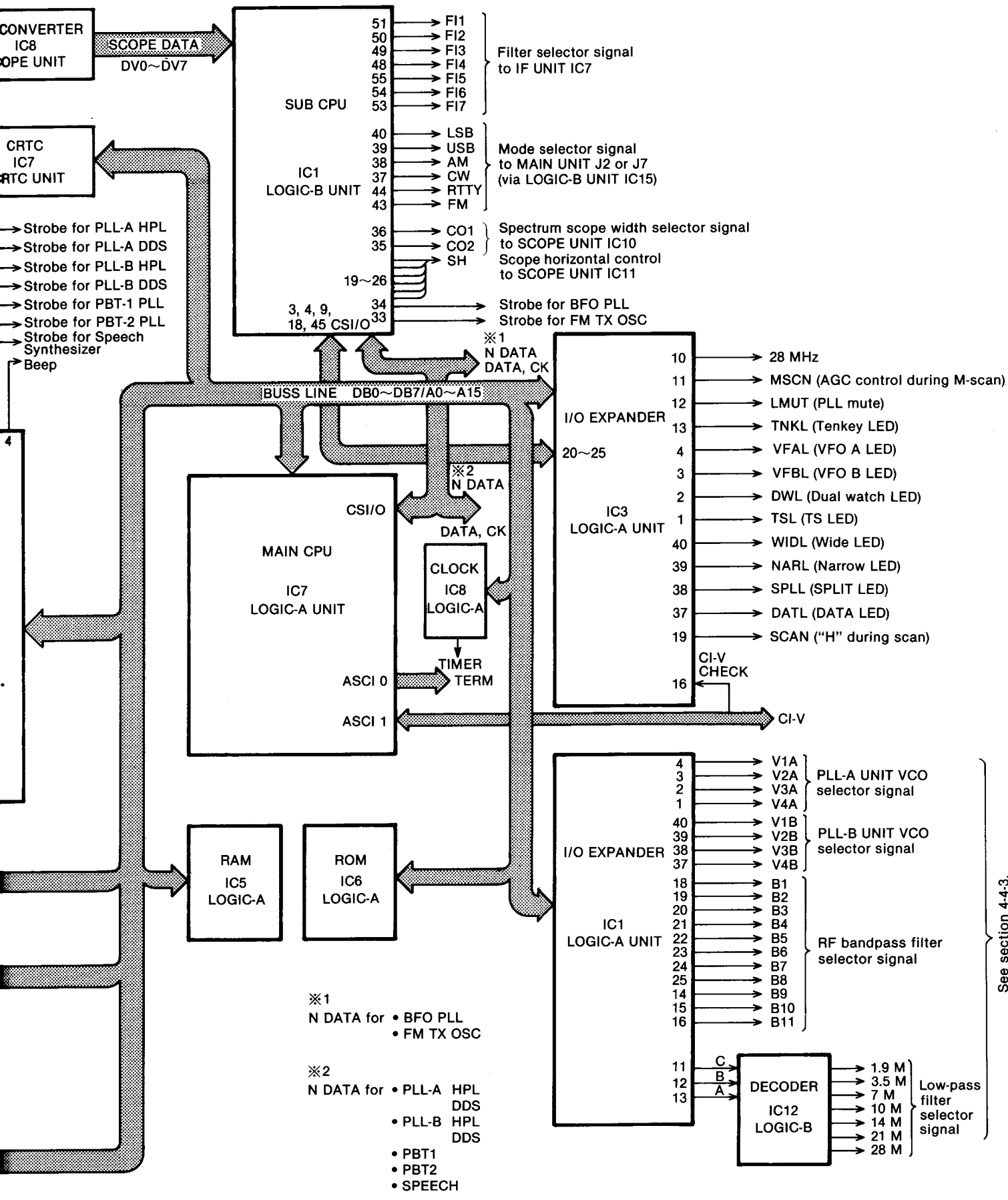

Fig. 18



## 4-5 SCOPE UNIT

### 4-5-1 SCOPE RECEIVER CIRCUIT

The spectrum scope screen has a dynamic range of 60 dB and a sensitivity of 0.32  $\mu\text{V}$  when the pre-amplifier is ON. The spectrum scope not only has a high dynamic range and excellent sensitivity, but also is a precise instrument for signal analysis. Using a 46.51 MHz 1st IF signal from the RF UNIT, the SCOPE UNIT creates an 8-bit scope signal.

The 1st IF signal amplified at Q10 in the RF UNIT enters the SCOPE UNIT via P1 (RF UNIT: J8). The signal passes through the pin diode attenuator (D1, D2) which is controlled by a scope AGC circuit. The signal is then amplified at Q1 and converted to a 4.7 MHz signal at IC1 with a 51.2 MHz LO signal. The LO signal, oscillated at Q3 and X1, is amplified at Q2.

The converted signal, filtered at the high-pass filter and the bandpass filter, is amplified at Q4. The signal is mixed with the sweep signal at IC4 to be converted into a 390 kHz swept signal.

The sweep signal is generated at Q10. The generated frequency is controlled by IC10 and D15 with the "SH" signal (a digital sawtooth waveform). The sweep width of  $\pm 25$  kHz,  $\pm 50$  kHz and  $\pm 100$  kHz is selected at IC10 using the "CO1" and "CO2" lines. The sweep signal is amplified at Q11 and applied to the mixer (IC5). Q3 generates a 51.2 MHz signal which is divided at IC2 by 10. IC5 mixes the 5.12 MHz signal with the sweep signal. The mixed signal is amplified at Q5 and applied to IC4 as the sweep signal.

The 390 kHz swept signal is filtered at a low-pass filter and the bandpass filter using the ceramic resonator (X2, X3). This filter has characteristics of 600 Hz $\sim$ 1 kHz/ $-3$  dB. The filtered signal is amplified at Q7 and Q6 and applied to the logarithmic detector (IC6). IC6 detects the swept signal and converts it into DC voltage.

A DC voltage is differentially amplified at IC7a to obtain an output of 0 $\sim$ 3 V DC. This output is converted to an 8 bit digital signal at IC8. The 8 bit digital signal is applied to the sub CPU (IC1) in the LOGIC-B UNIT to display the detected signal on the spectrum scope screen.

### 4-5-2 AGC CIRCUIT

A portion of the 390 kHz swept signal is amplified at Q8 and detected at D8 and D9. The detected signal is inversion-amplified at IC3b and is then applied to the source of Q1, Q4 and Q7 as the bias voltage. The amplified signal at IC3b is also applied to a pin diode (D1) after inversion-amplification at IC3a.

## 4-6 ANTENNA TUNER CIRCUITS

### 4-6-1 MATCHING CIRCUIT

The matching circuit is a T network. Using two motors, the matching circuit obtains rapid overall tuning speed.

Using relays (RL204 $\sim$ RL209), the LPF (low-pass filter) selector signal from the LOGIC-B UNIT grounds one of the taps of L210 and additional coils (L211 $\sim$ L213). The LPF selector signal also connects the combination of the capacitors C201/C202 or C203/C204 in parallel to the variable capacitors (C303 and C304) when operating in the 1.8 $\sim$ 3.5 MHz range.

### SCOPE UNIT: BLOCK DIAGRAM

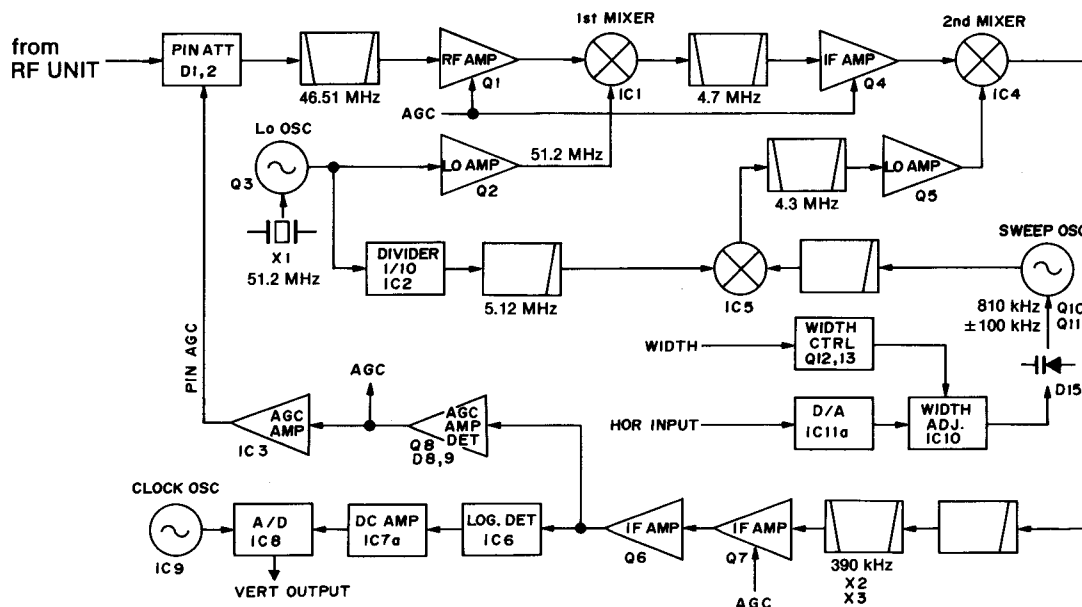

Fig. 19

After selecting the coils or capacitors, two motors (MF1, MF2) adjust C303 and C304 using the output of the motor control circuit to obtain a low SWR.

### MATCHING CIRCUIT: BLOCK DIAGRAM

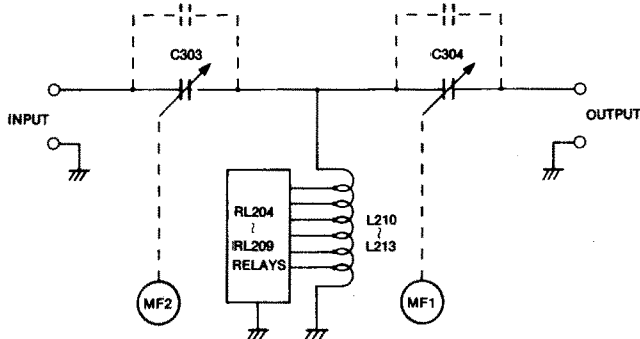

Fig. 20

### 4-6-2 DETECTOR CIRCUIT

The antenna tuner has two detector circuits: a resistance component detector and a reactance component detector.

Resistance components are picked up by L6 and detected by D16 and D15 on the TUNER 2 UNIT. D16 outputs negative voltage and D15 outputs positive voltage. Output voltage of the resistance component detector is added to the voltage output from D16 and D15. When antenna impedance is higher than 50  $\Omega$ , output voltage is negative; when lower than 50  $\Omega$ , positive.

Reactance components are picked up by comparing the phases of the RF current and RF voltage. The RF current is detected by L6 and R43. RF voltage is detected by C42~C44. Both detector voltages are buffer amplified at Q13 and Q14, and are then applied to the phase comparator (IC3~IC5). The output signal of IC5 is detected at D13 and D14. When the RF current phase leads the voltage phase, the detected voltage is negative; when the current lags the voltage, the detected voltage is positive.

### DETECTOR CIRCUIT: BLOCK DIAGRAM

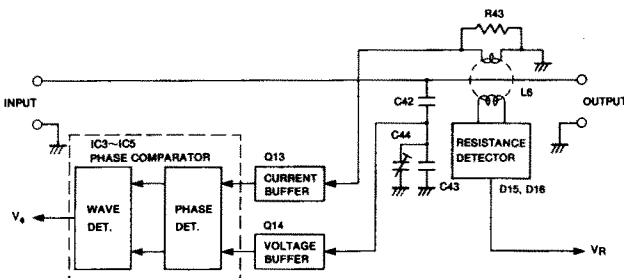

Fig. 21

### 4-6-3 MOTOR CONTROL CIRCUIT

The output signal of the resistance detector ( $V_R$ ) is amplified at IC1B and current amplified at Q1 and Q2. The signal then drives the motor (MF1) in the matching circuit. The variable resistor (R301) is connected to C304 to detect C304 rotation. The detected voltage is applied to the comparator (IC1A) to be compared to the preset voltage adjusted at R101.

The output signal of the reactance detector ( $V_\phi$ ) is amplified at IC2A and current amplified at Q7 and Q8. The signal then drives the motor (MF2) in the matching circuit. C303 rotation is detected at R302. The detected voltage is applied to IC2B together with the preset voltage adjusted at R102.

When the operating band is changed, a pulse signal is applied to IC102 pin 13. The integral circuit (C125, R115) charges this pulse signal and turns RL1 ON until C303 and C304 move to their preset positions. The preset position is detected by comparators IC1A and IC2B.

Q3~Q6 and Q9~Q12 protect the variable resistors (R301, R302) from excess current.

### MOTOR CONTROL CIRCUIT

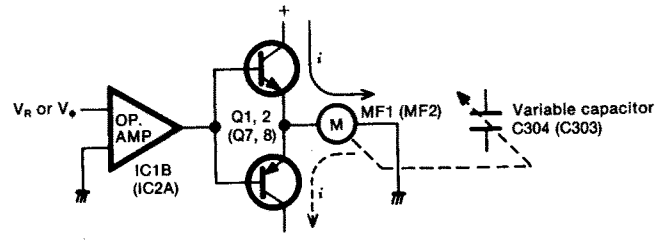

Fig. 22

### 4-7 POWER SUPPLY CIRCUITS

The power supply circuit mainly consists of a 280 V DC rectifier, a start-up circuit, a 15 and 28 V DC switching regulator, a 5, 9, 12 V DC regulator and a -9 V converter.

When turning ON the power, the 15 and 28 V switching regulator operates with the start-up circuit output voltage. After several milliseconds, the switching regulator operates on its own output voltage.

#### 4-7-1 RECTIFIER CIRCUIT (PI UNIT)

An AC voltage from the AC power socket passes through the [POWER] switch and is applied to the PI UNIT. The AC voltage passes through the line filter (L8, C26, C27) and R20. R20 prevents an entry of current until 15 V DC are supplied from the REG UNIT. After 15 V DC are regulated, the AC voltage bypasses R20 through RL1.

Either 100 or 200 V AC input is selected by a plug, P2. The selected AC input is rectified and filtered by D1 and C1~C4 to obtain 280 V DC. 280 V DC are then applied to the REG UNIT. R1 and R2 keep the voltage balance of C1~C4 constant.

#### 4-7-2 START-UP CIRCUIT (PI AND REG UNITS)

The AC voltage is applied to a transformer (T1), rectified by D3, and applied to a start-up regulator in the REG UNIT. The start-up regulator (Q5, Q6) supplies 15 V DC to IC1 until C29 is fully charged. When the switching regulator is activated, the start-up circuit deactivates. IC1 then continuously generates 15 V DC, supplying the voltage to itself through D1.

When the timer function turns OFF the power, the "BU" signal line becomes "HIGH," selecting RL2 for the "M" side. The AC voltage from T1 is rectified by D4. The rectified DC voltage activates Q4 and Q5.

#### 4-7-3 SWITCHING REGULATOR (REG UNIT)

Passing through a line filter, 280 V DC from the PI UNIT are applied to the TR UNIT to be converted to a pulse signal, which is then applied to a transformer (T2). T2 has two secondary windings for 15 V and 28 V.

The output voltages from the 15 V winding are rectified and filtered by D2, C15 and C16 to obtain 15 V DC. The 15 V DC are fed back to the switching regulator IC (IC1). IC1 contains a 5 V reference voltage circuit, op-amp, comparator and current limiter circuit. IC1 controls the pulse generator (Q1~Q4) and compares the feedback voltage to the reference voltage.

The output voltages from the 28 V winding are rectified by D3 in the DI UNIT, and are filtered by C20~C23 to obtain 28 V DC. When high current is consumed, the output voltages are controlled by IC1. When low current is consumed, the output voltages are not controlled by IC1. Therefore, the bleeder circuit (Q7, D5) prevents a voltage increase in the 28 V DC line during a no-load period. Q7 controls bleeder current using a 16 V Zener diode.

A 0.001  $\Omega$  resistor (R22) in the GND line provides detection of the total current limiter.

#### 4-7-4 REGULATOR CIRCUITS (PI AND REG UNITS)

Either 12, 9, 5 or -9 V DC are supplied from their corresponding regulator circuits. 12, 9 and 5 V DC are regulated from the 15 V DC.

##### (1) 5 V REGULATOR (REG UNIT)

5 V DC are regulated by the three-terminal voltage regulator (IC2).

##### (2) 9 V REGULATOR (REG UNIT)

9 V DC are regulated by Q8~Q11. Q10 is a current limiter which reduces the current when the output current of 9 V DC exceeds 1.2 A. R35 is a current detector.

#### SWITCHING REGULATOR: BLOCK DIAGRAM

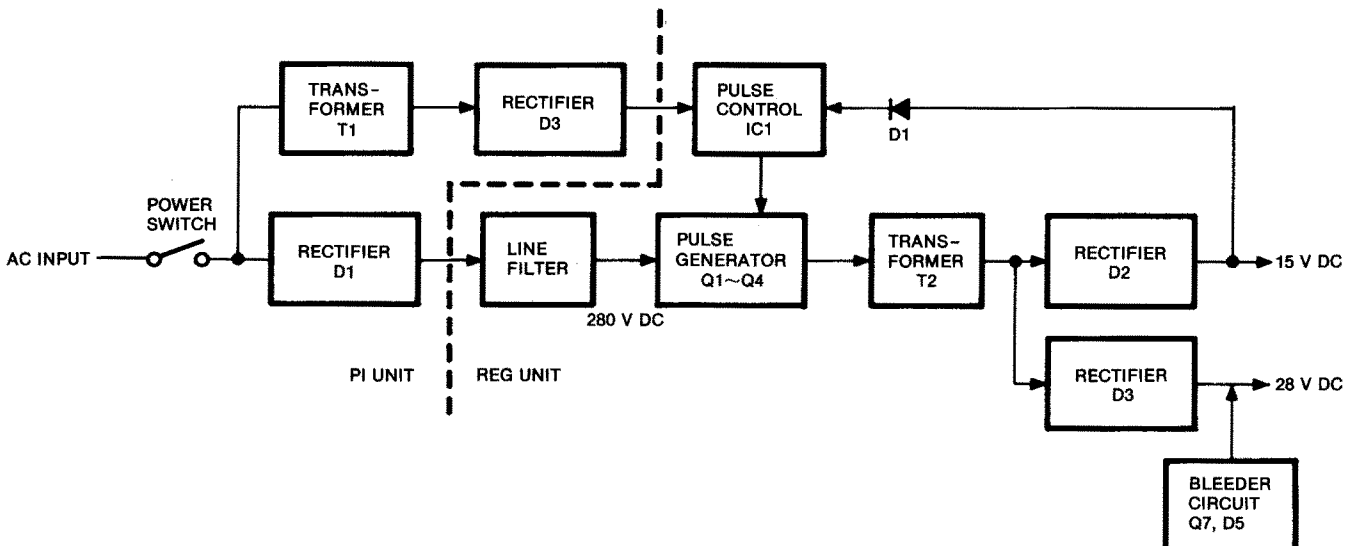

Fig. 23

### (3) -9 V REGULATOR (PI UNIT)

The AC voltage from T1 is rectified at D2 and applied to a -9 V regulator circuit (Q1~Q3). Q3 is a differential amplifier and one of its bases is grounded. Hence, a -9 V regulator circuit outputs a negative voltage equivalent to the reference voltage.

### (4) 12 V REGULATOR (PI UNIT)

12 V DC are regulated by Q6~Q8 for the DISPLAY UNIT. The DISPLAY UNIT requires very stable 12 V DC.

## 4-7-5 DC-DC UNIT

The DC-DC UNIT generates a negative voltage by converting the DC input to AC voltages (approx. 16 kHz) with a multivibrator (Q1, Q2, L2). After D3 and D4 rectify the full AC wave, a negative voltage equivalent to the input voltage is obtained. The voltage is applied to the TUNER and SCOPE UNITS.

### DC-DC UNIT

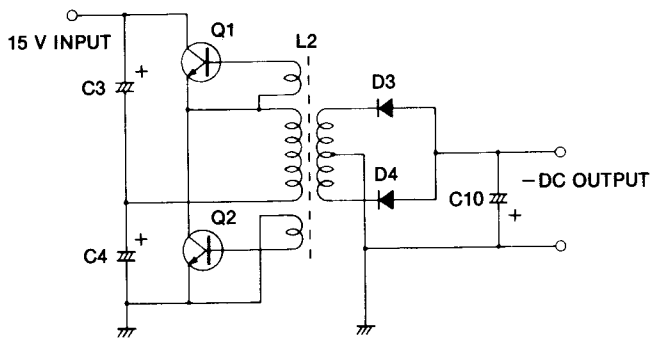
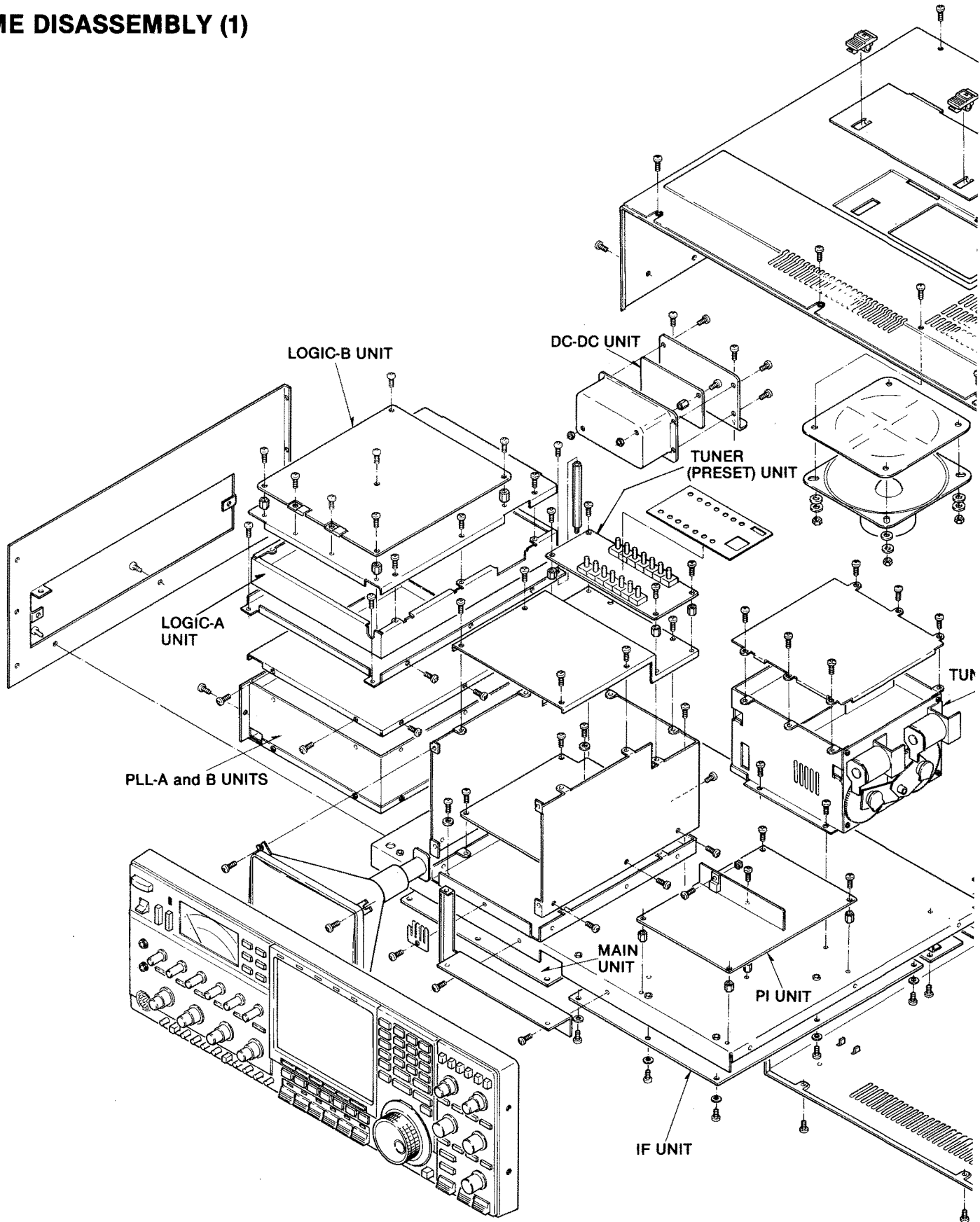

Fig. 24



# SECTION 5 MECHANICAL PARTS AND DISASSEMBLY

## 5-1 FRAME DISASSEMBLY (1)



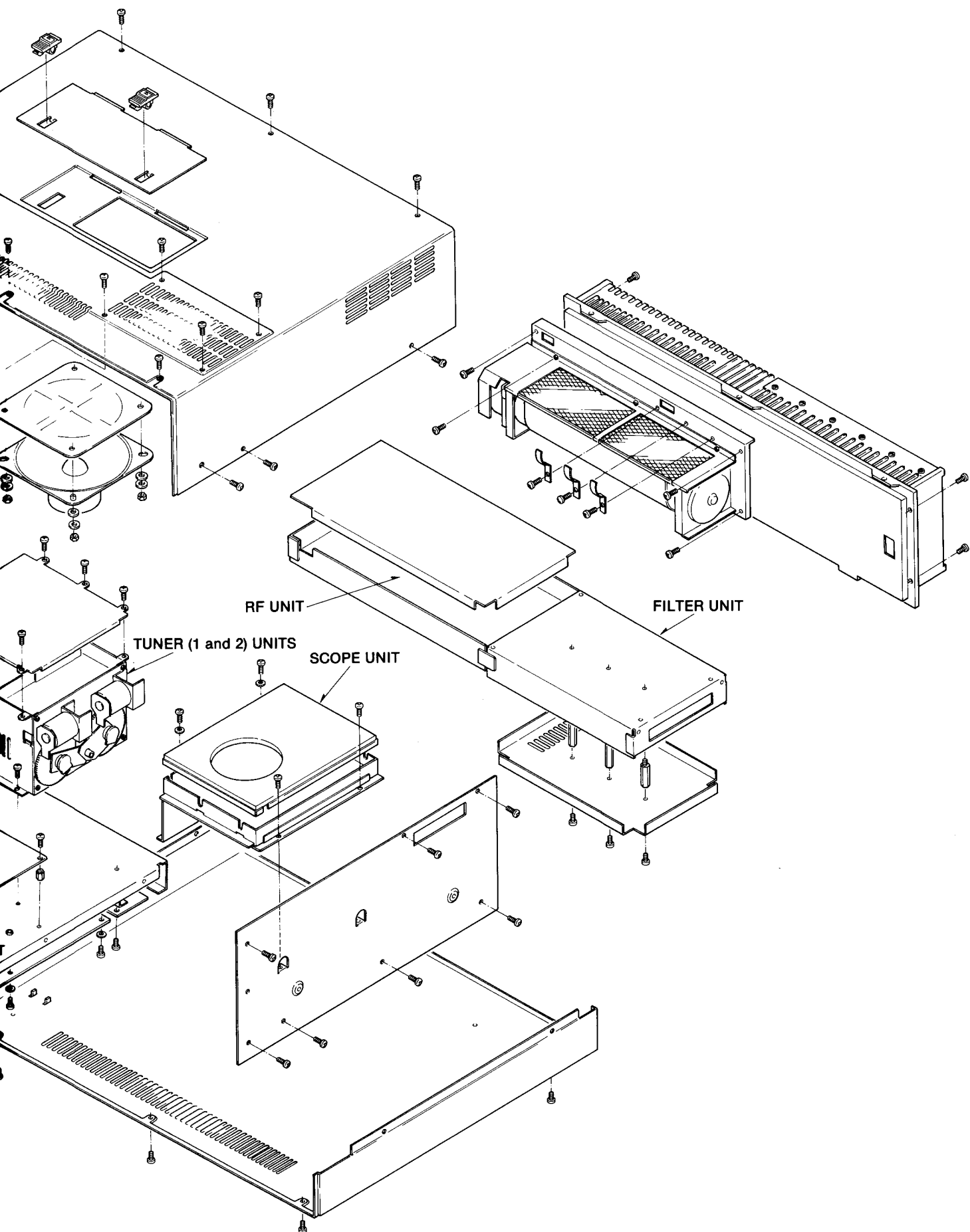

## 5-2 FRAME DISASSEMBLY (2)

NUMBER IN DIAGRAM	DESCRIPTION	ORDERING NUMBER	QTY.
①	Bottom cover (rubber stand assembled)	8110001970	1
②	Chassis (left side)	8010006890	1
③	Filter shield plate	8930012020	1
④	RF chassis	8510004950	1
⑤	RF shield plate	8510004880	1
⑥	Heatsink hood	8010006901	1
⑦	Fan cover	8010007131	1
⑧	Contact spring (C)	8930004070	3
⑨	Shield plate (SCOPE UNIT)	8510002901	1
⑩	DC-DC cover	8510000430	1
⑪	DC-DC case	8510000420	1
⑫	Standoff	8930011540	1
⑬	CRT upper plate	8510004960	1
⑭	CRT side plate	8010006950	1
⑮	PLL top casing	8510004900	1
⑯	PLL chassis	8010006930	1
⑰	PLL bottom casing	8510004890	1
⑱	LOGIC-A chassis	8510004970	1
⑲	LOGIC-A bottom casing	8510004930	1
⑳	Chassis (right side)	8010006880	1
㉑	Heatsink (PI UNIT)	8410000611	1
㉒	Center chassis	8010006910	1
㉓	LOGIC-A top casing	8510004910	1
㉔	Access cover	8110001990	1
㉕	Top cover (speaker assembled)	8110001980	1
㉖	PI cover	8110001960	1
㉗	Access cover latch	8930011660	2
㉘	Preset control VR-plate	8310011560	1

### • CONTACT SPRINGS

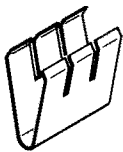

8930001180



8930001160

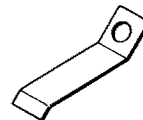

8930001170

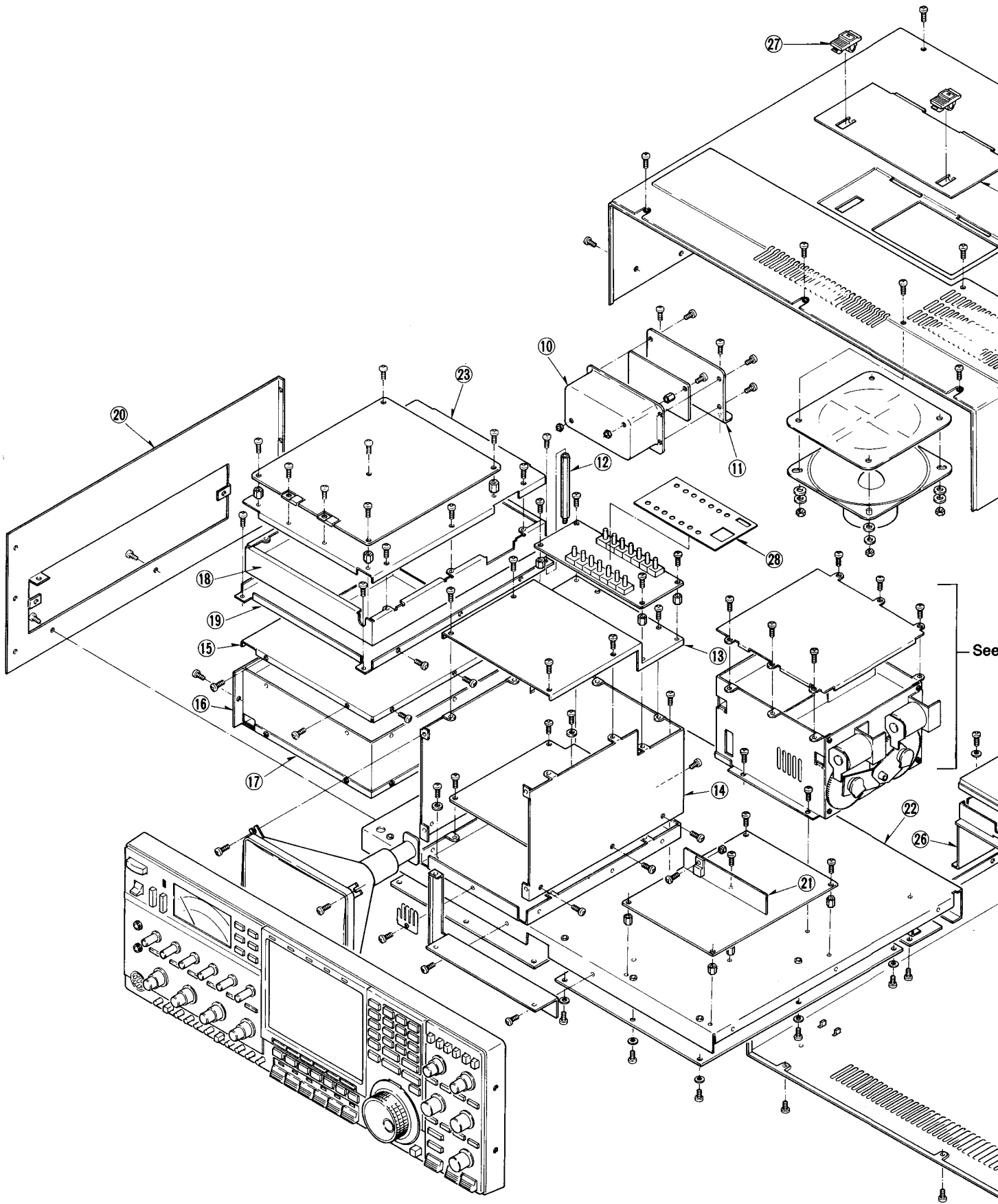

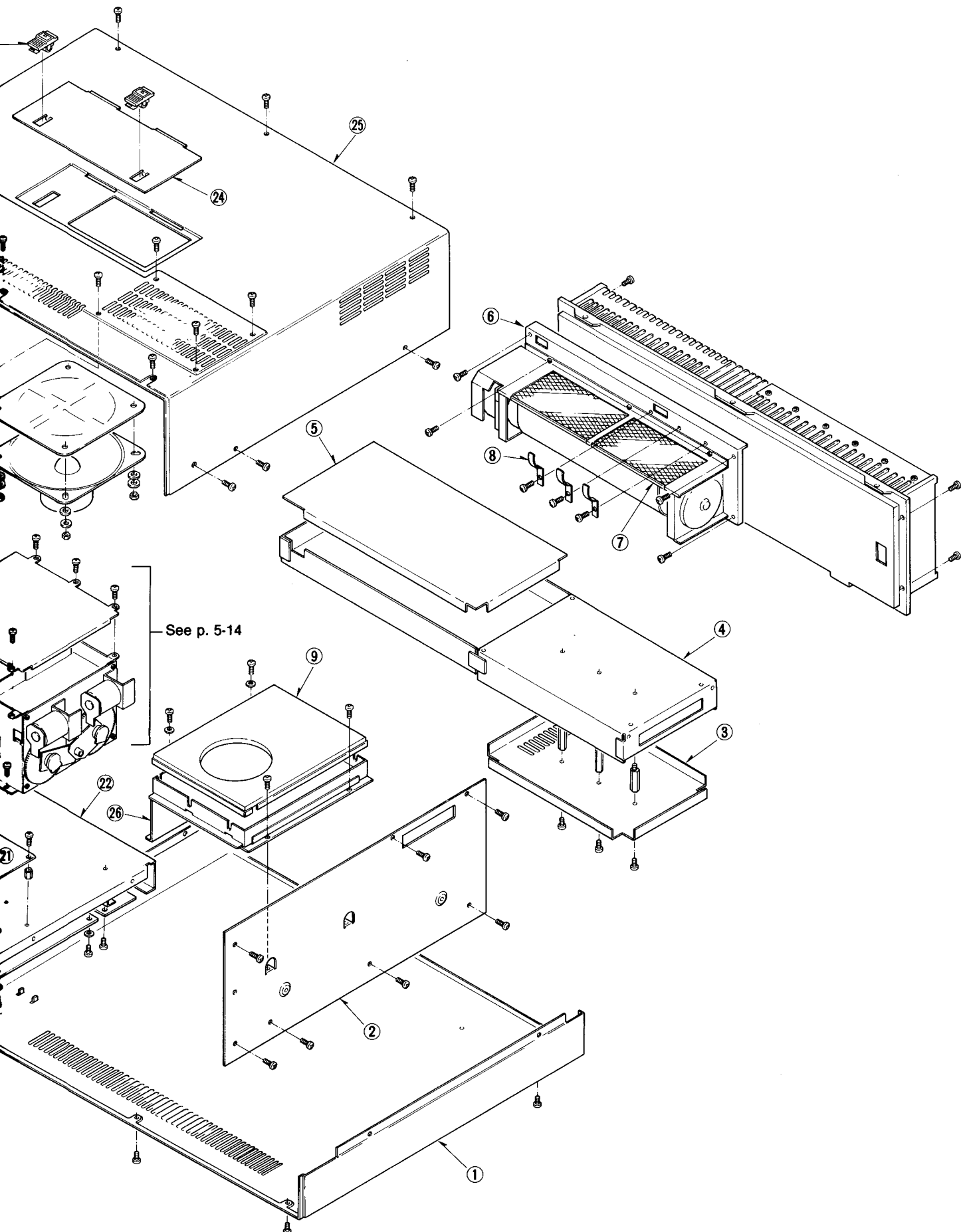

### 5-3 FRAME DISASSEMBLY (3)

NUMBER IN DIAGRAM	DESCRIPTION	ORDERING NUMBER	QTY.
①	FH D=6 M4×6 SUS ZK	8810004970	10
②	ICOM screw (A) 5	8810003660	3
③	Set screw (C) M3×6	8810003360	4
④	Set screw (A) M3×5	8810003150	7
⑤	Set screw (A) M3×6	8810003160	5
⑥	Spring washer M4	8850000430	4
⑦	Washer M4	8850000140	4
⑧	FH M4×8	8810003120	4
⑨	Nut M4	8830000110	4
⑩	ICOM screw (C) 8	8810003920	9
⑪	PH M2×4	8810000010	2
⑫	PH B1 3×6	8810001350	4
⑬	ICOM screw (C) 10	8810003760	5
⑭	Set screw (A) M2.6×4	8810004750	6
⑮	Set screw (C) M3×5	8810003350	4
⑯	Set screw (A) M3×8	8810003170	1
⑰	ICOM screw (C) 9	8810003750	4
⑱	Half thread spacer (B)	8930006070	5
⑲	ICOM screw (B) 1	8810003700	2
⑳	FH M2.6×4	8810002100	26
㉑	FH M3×6	8810002480	2
㉒	PH M2.6×5	8810000140	6
㉓	ICOM screw (C) 8	8810003920	5
㉔	Nut M3	8830000100	1

**Screw type**

Screw: M2.6×4, M3×6, M3×8, M4×6

**Screw head style**

PH: Pan head, FH: Flat head

**Icom standard screw**

Set screw (A): Pan head screw with spring washer

Set screw (C): Pan head screw with spring and flat washers

ICOM screw (A): Button head screw (silver color)

ICOM screw (B): Button head screw (black color)

ICOM screw (C): Button head screw with half thread (silver color)

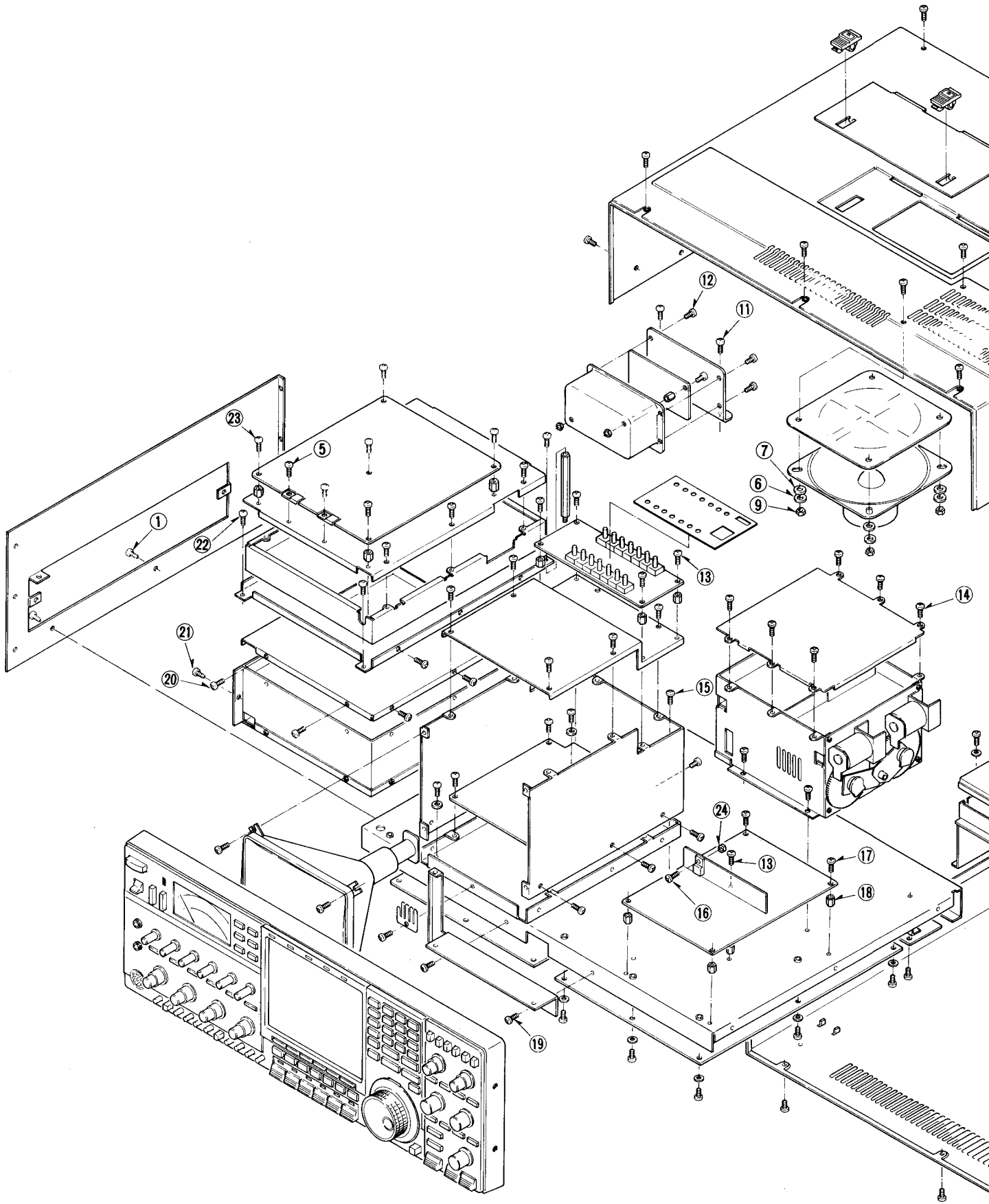

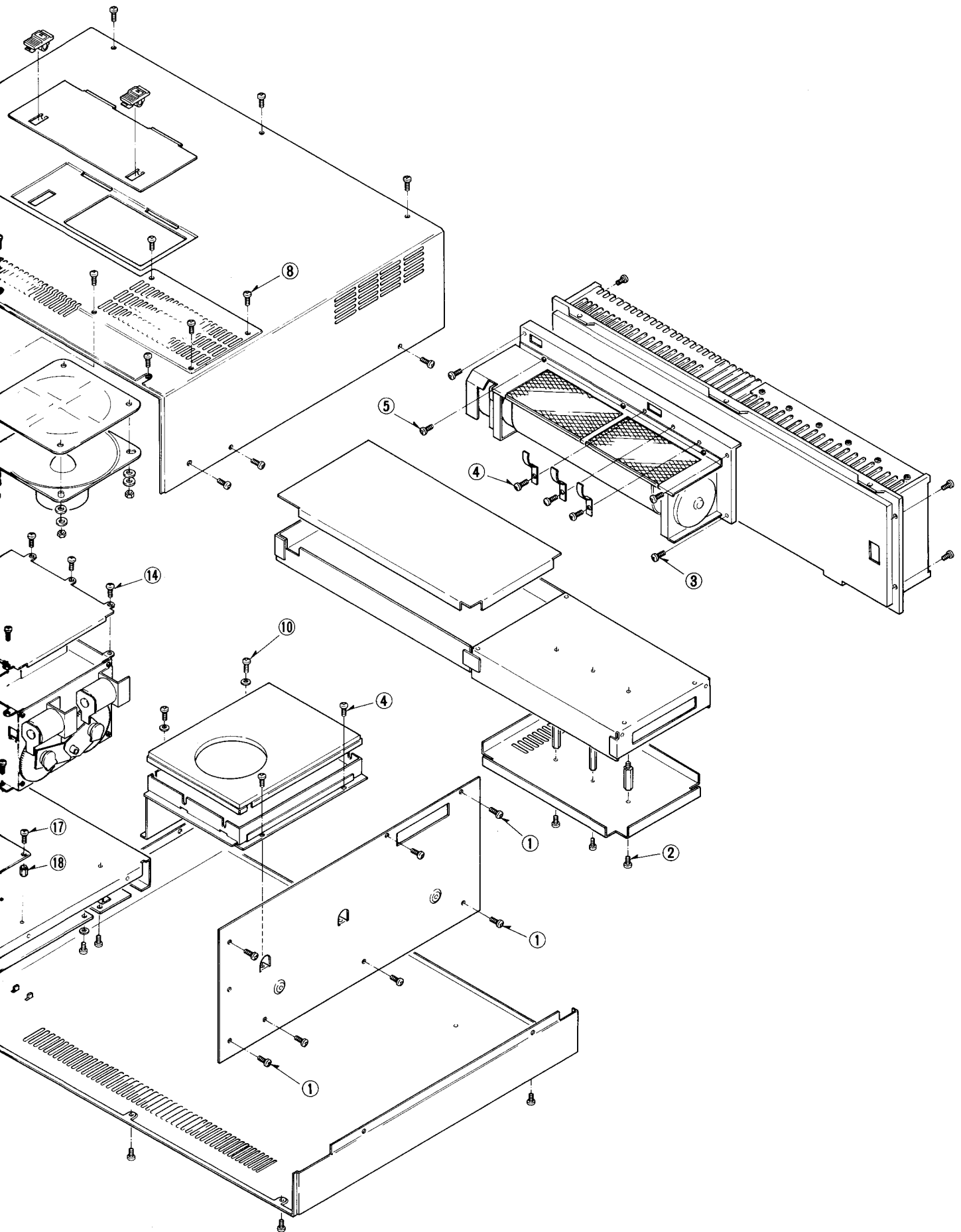



## 5-4 FRONT PANEL DISASSEMBLY (1)

NUMBER IN DIAGRAM	DESCRIPTION	ORDERING NUMBER	QTY.
①	Knob (N120)	8610004150	6
②	Knob (N121)	8610004160	6
③	Knob (N118) (including HLH)	8610003300	6
④	Knob (N124) (including HLH)	8610004190	1
⑤	Rubber seal	8010007480	1
⑥	Knob (N122)	8610004170	1
⑦	Knob (N123)	8610004180	2
⑧	Front panel	8210002840	1
⑨	CRT rubber seal	8930011670	1
⑩	Button (K97)	8610003840	6
⑪	Button (K79)	8610002840	1
⑫	Front sub chassis	8010006941	1
⑬	Button (K80)	8610002850	2
⑭	Button	8930006940	2
⑮	Push knob (N102 (A))	8610003630	8
⑯	Button (K101 (F)) [M ► VFO]	8610004050	1
⑰	Button (K101 (G)) [▽ DOWN]	8610004060	1
⑱	Button (K101 (H)) [UP △]	8610004070	1
⑲	Button (K105)	8610004140	2
⑳	Button (K103)	8610004090	8
㉑	Button (K66 (A))	8610002540	2
㉒	Button (K102)	8610004080	6
㉓	Button (K98)	8610003850	6

Screw head style HLH: Headless hex

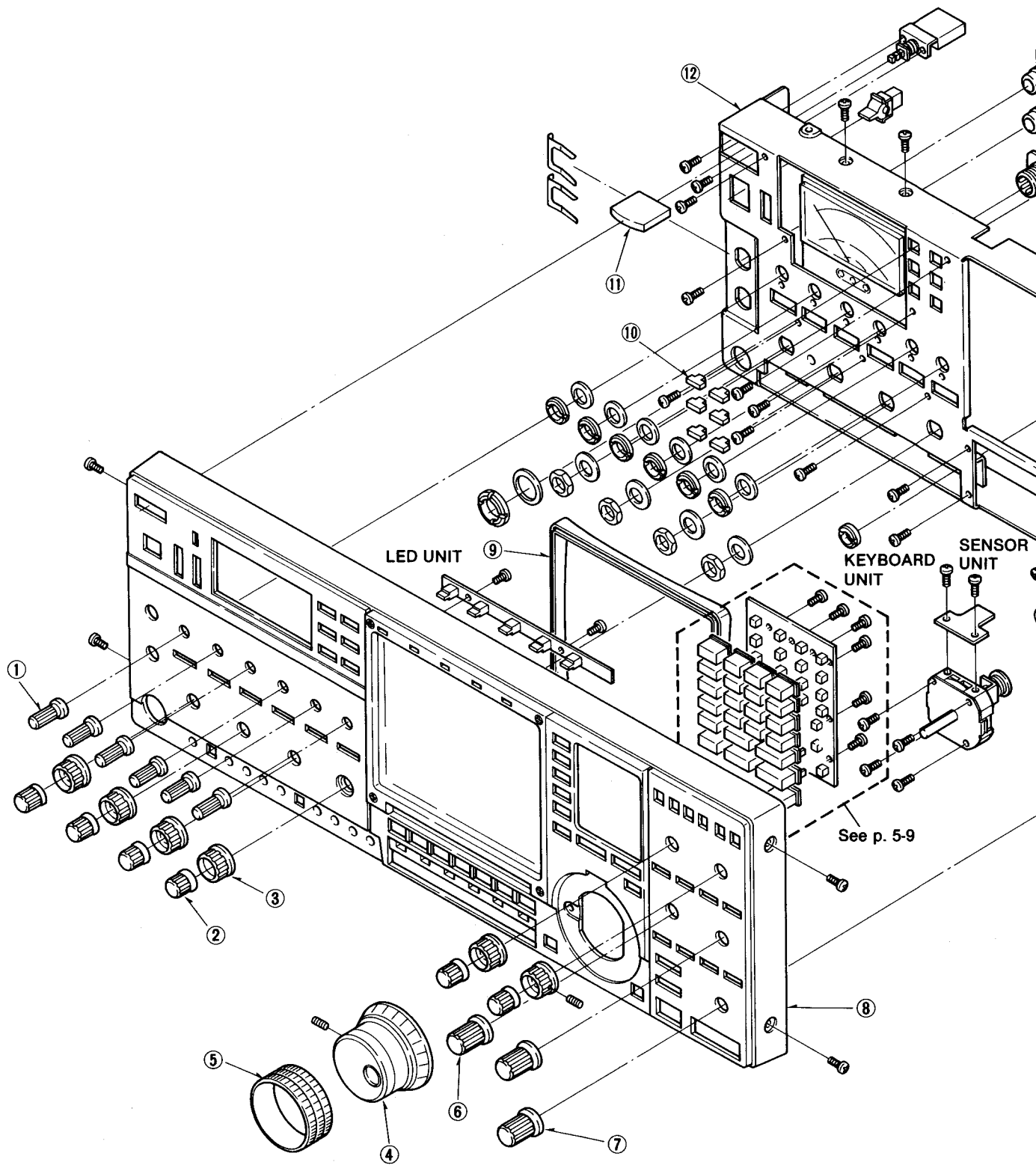

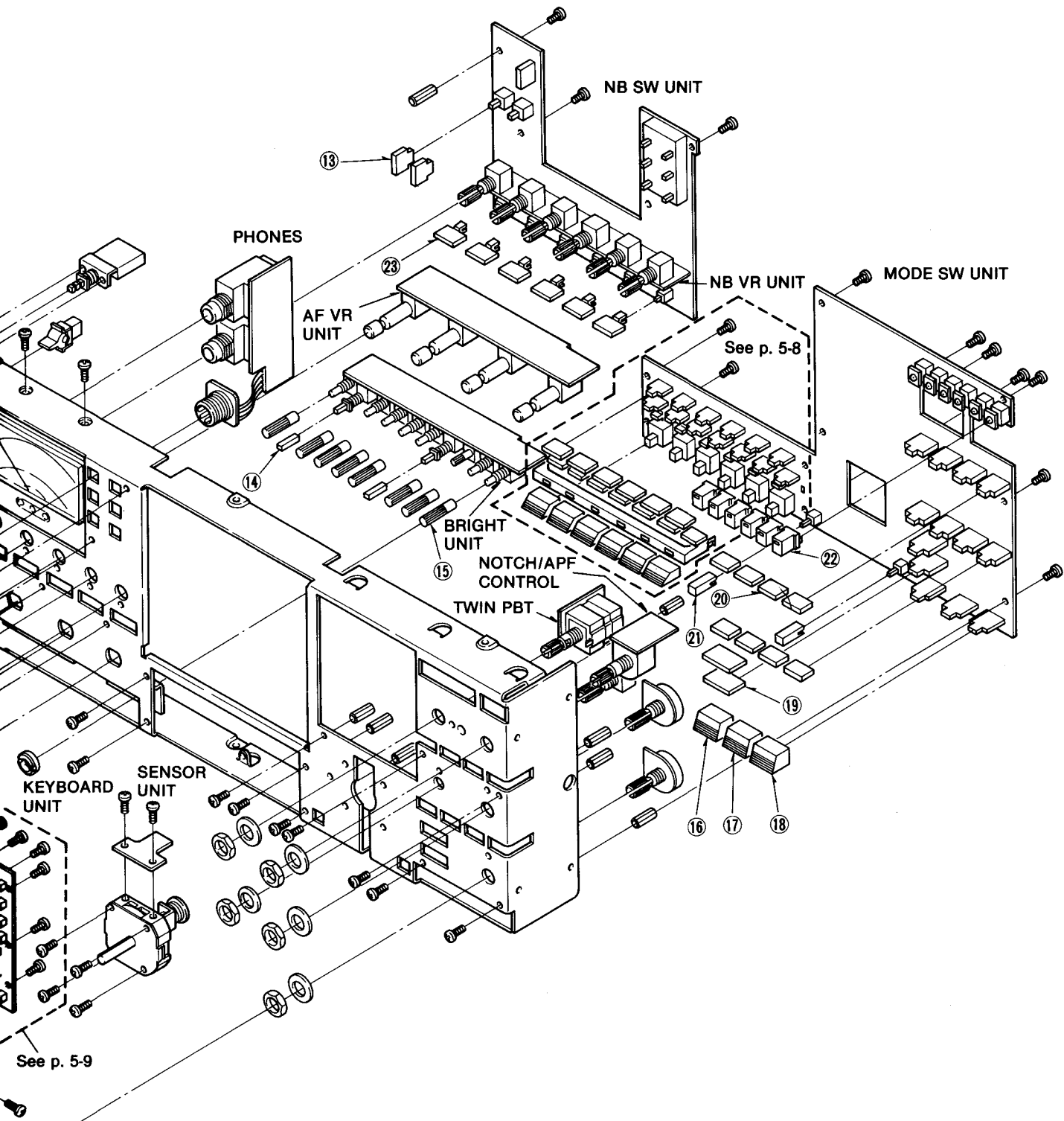

• MODE SW UNIT

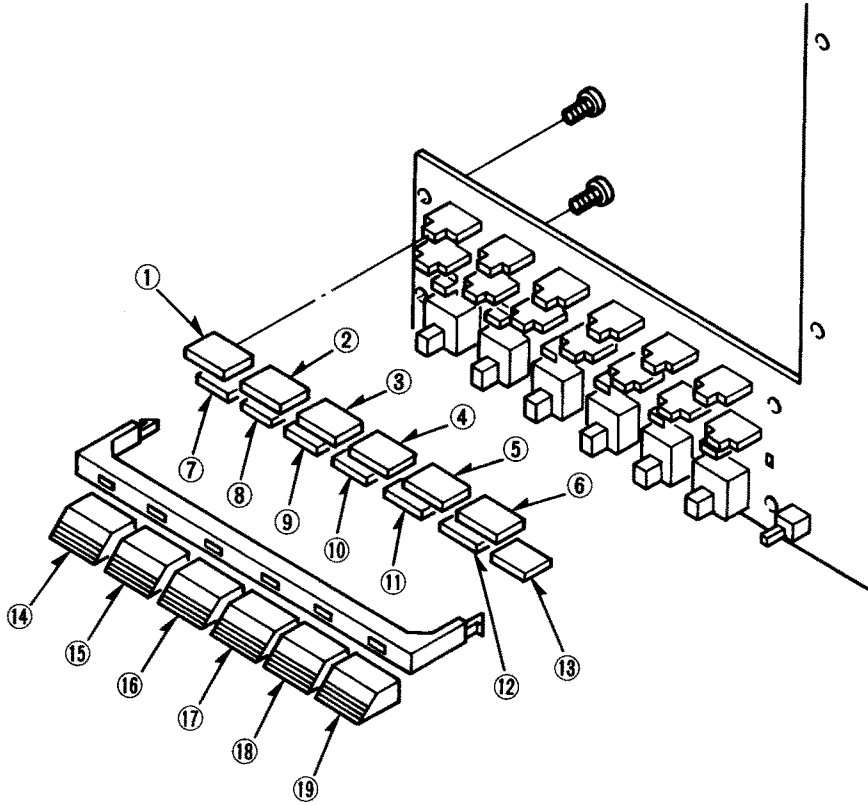

NUMBER IN DIAGRAM	DESCRIPTION	ORDERING NUMBER	QTY.
①	Button (K99) [F-1]	8610003860	1
②	Button (K99 (A)) [F-2]	8610003870	1
③	Button (K99 (B)) [F-3]	8610003880	1
④	Button (K99 (C)) [F-4]	8610003890	1
⑤	Button (K99 (D)) [F-5]	8610003900	1
⑥	Button (K99 (E)) [F-6]	8610003910	1
⑦	Button (K100) [LSB]	8610003920	1
⑧	Button (K100 (A)) [USB]	8610003930	1
⑨	Button (K100 (B)) [CW]	8610003940	1
⑩	Button (K100 (C)) [RTTY]	8610003950	1
⑪	Button (K100 (D)) [AM]	8610003960	1
⑫	Button (K100 (E)) [FM]	8610003970	1
⑬	Button (K100 (F)) [DATA]	8610003980	1
⑭	Button (K101) [PREAMP]	8610003990	1
⑮	Button (K101 (A)) [ATT 10 dB]	8610004000	1
⑯	Button (K101 (B)) [ATT 20 dB]	8810004010	1
⑰	Button (K101 (C)) [MARKER]	8810004020	1
⑱	Button (K101 (D)) [MONITOR]	8610004030	1
⑲	Button (K101 (E)) [TONE]	8610004040	1

• KEYBOARD UNIT

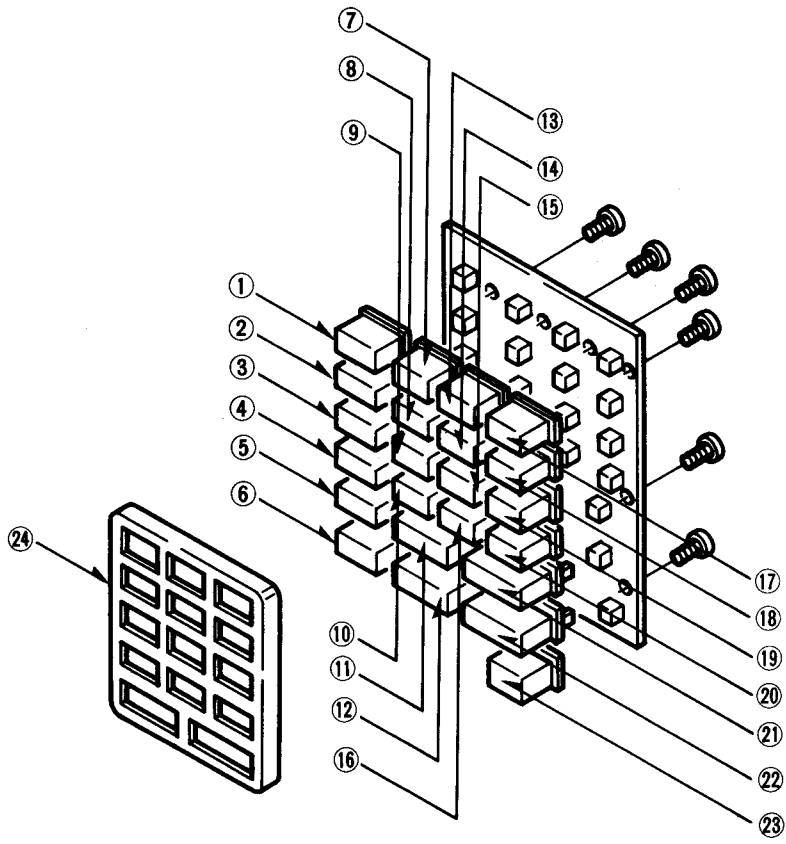

<b>NUMBER IN DIAGRAM</b>	<b>DESCRIPTION</b>	<b>ORDERING NUMBER</b>	<b>QTY.</b>
①	Button (K92 (F)) [A = B]	8610003660	1
②	Button (K92 (G)) [A]	8610003670	1
③	Button (K92 (H)) [CHANGE]	8610003680	1
④	Button (K92 (I)) [B]	8610003690	1
⑤	Button (K92 (E)) [SPLIT]	8610003650	1
⑥	Button (K92 (J)) [XFC]	8610003700	1
⑦	Button (K92 (K)) [1]	8610003710	1
⑧	Button (K92 (N)) [4]	8610003740	1
⑨	Button (K92 (Q)) [7]	8610003770	1
⑩	Button (K92 (T)) [.]	8610003800	1
⑪	Button (K104) [M-CH]	8610004100	1
⑫	Button (K104 (B)) [DUAL WATCH]	8610004120	1
⑬	Button (K92 (L)) [2]	8610003720	1
⑭	Button (K92 (O)) [5]	8610003750	1
⑮	Button (K92 (R)) [8]	8610003780	1
⑯	Button (K92 (U)) [0]	8610003810	1
⑰	Button (K92 (M)) [3]	8610003730	1
⑱	Button (K92 (P)) [6]	8610003760	1
⑲	Button (K92 (S)) [9]	8610003790	1
⑳	Button (K92 (V)) [CE]	8610003820	1
㉑	Button (K104 (A)) [ENT]	8610004110	1
㉒	Button (K104 (C)) [VFO/MEMO]	8610004130	1
㉓	Button (92 (W)) [TS]	8610003830	1
㉔	Keyboard panel	8210002850	1



## 5-5 FRONT PANEL DISASSEMBLY (2)

NUMBER IN DIAGRAM	DESCRIPTION	ORDERING NUMBER	QTY.
①	BiH M4 × 5 ZK	8810004690	5
②	PH M2.6 × 12	8810000180	4
③	VR-Nut (C)	8830000030	8
④	PH M2 × 4	8810000010	8
⑤	FH (-) M2.6 × 6 ZK	8810004770	4
⑥	VR-Nut (A)	8830000040	6
⑦	VR-Nut (B)	8830000050	1
⑧	PH B0 M2 × 4	8810000980	2
⑨	PH M3 × 4	8810000210	16
⑩	Set screw (A) M3 × 5	8810003150	2
⑪	PH B0 M2.6 × 6	8810001040	2
⑫	Thread spacer (X)	8930011520	7
⑬	Set screw (A) M3 × 6	8810003160	20
⑭	Thread spacer (V)	8930000720	9
⑮	PH B0 M2 × 4	8810001730	3

**Screw type**            Screw: M2 × 4, M2.6 × 6, M2.6 × 12, M3 × 4, M3 × 5  
**Screw head style**    PH: Pan head, BiH: Binding head  
**Set screw (A)**        Pan head screw with spring washer

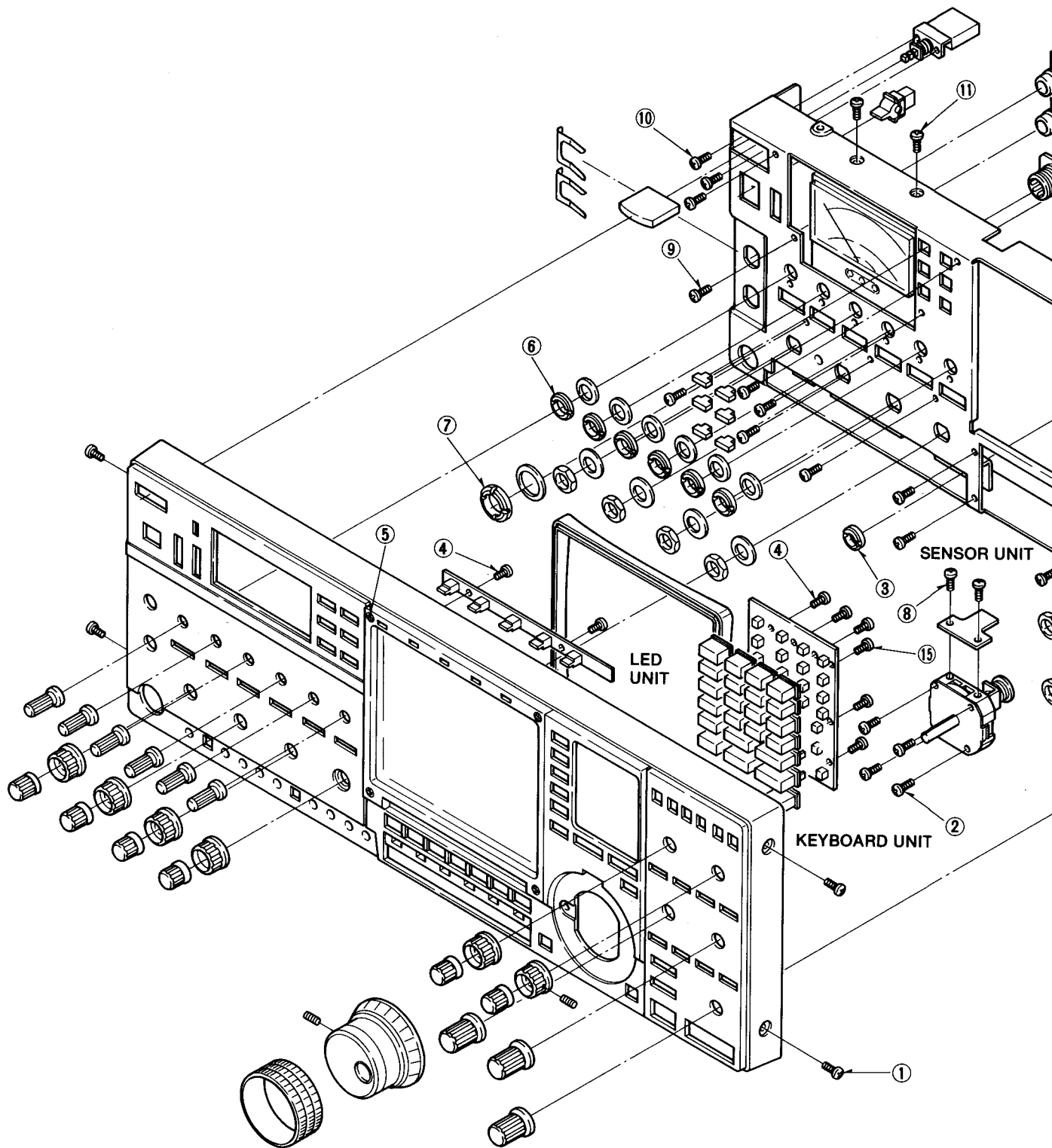

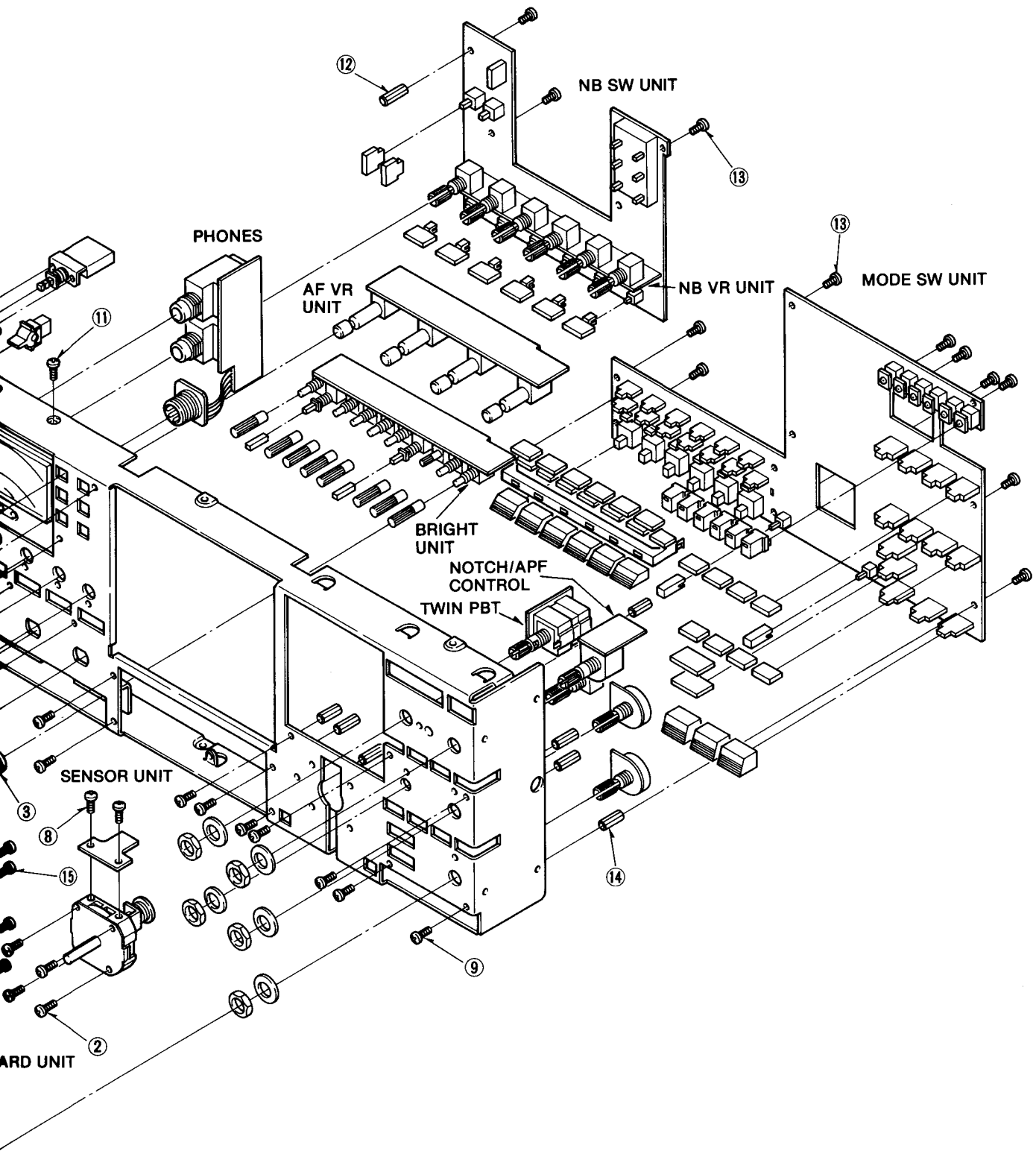

## 5-6 REAR PANEL (PA AND REG UNITS) DISASSEMBLY

NUMBER IN DIAGRAM	DESCRIPTION	ORDERING NUMBER	QTY.
①	ICOM screw (B) 5	8810003710	22
②	PA cover	8510004830	1
③	Shield plate	8510004920	1
④	Standoff (J)	8930000140	4
⑤	Set screw (A) M3 × 8	8810003170	13
⑥	Screw lug B-2 (M2.6)	8860000100	2
⑦	Set screw (A) M3 × 6	8810003160	5
⑧	Set screw (A) M3 × 18	8810003230	1
⑨	Thermal sensor plate	8930004200	1
⑩	Flat washer M3 Ni	8850000130	5
⑪	Spring washer M3 Ni	8850000420	7
⑫	Spacer (D)	8930000350	1
⑬	Heatsink	8410001121	1
⑭	Nut M3	8830000100	2
⑮	Standoff (C)	8930000060	2
⑯	Set screw (C) M3 × 6	8810003360	4
⑰	Transistor plate	8930011790	1
⑱	Set screw (C)	8810004760	1
⑲	Set screw (A) M2.6 × 8	8810003140	2
⑳	Shield plate	8510004860	1
㉑	REG cover	8510004870	1
㉒	Heatsink	8930011810	1

**Screw type**

Screw: M2.6 × 8, M3 × 6, M3 × 8, M3 × 18

**Icom standard screw**

Set screw (A): Pan head screw with spring washer

Set screw (C): Pan head screw with spring and flat washers

ICOM screw (B): Button head screw (black color)

REG UNI

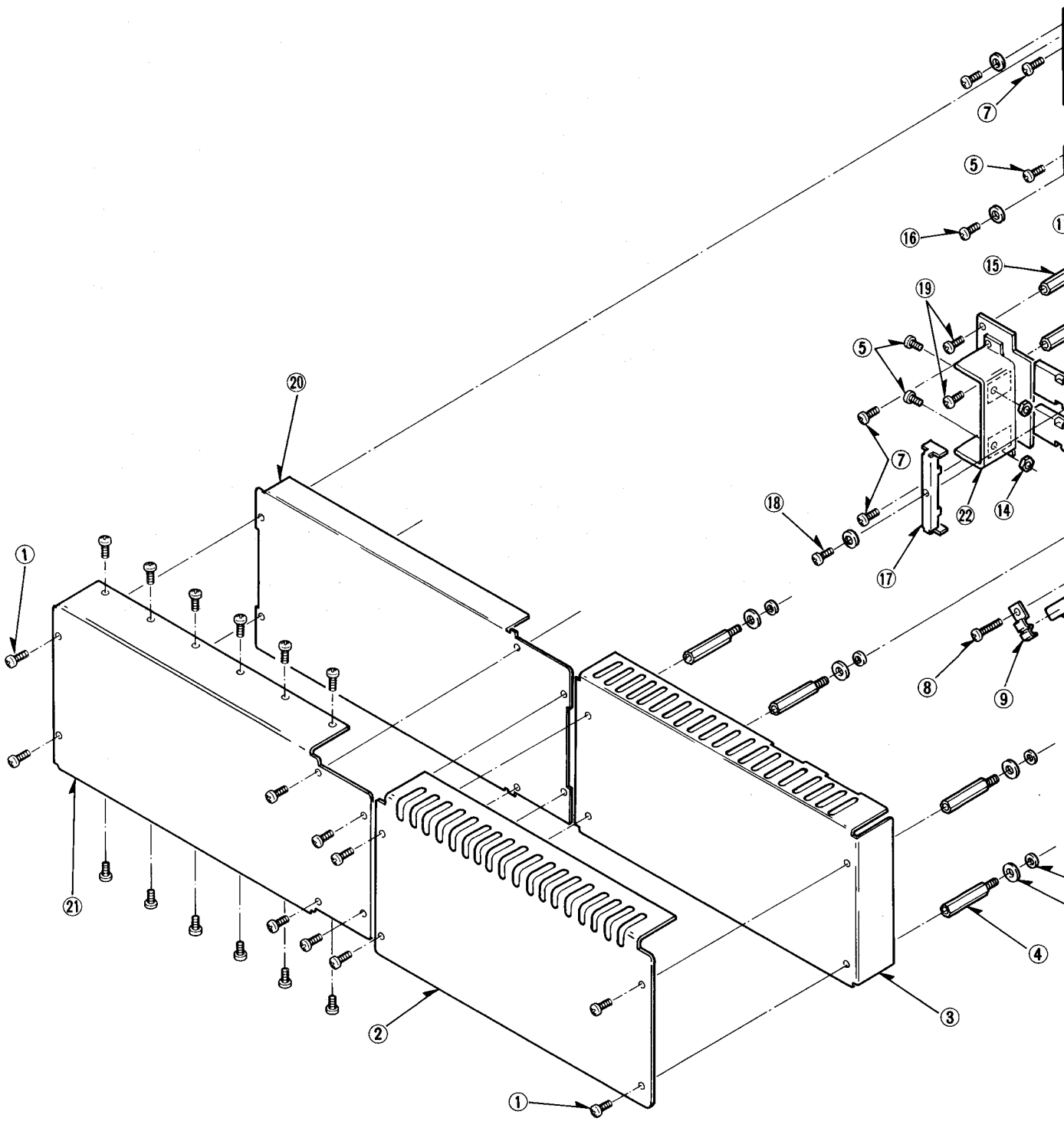

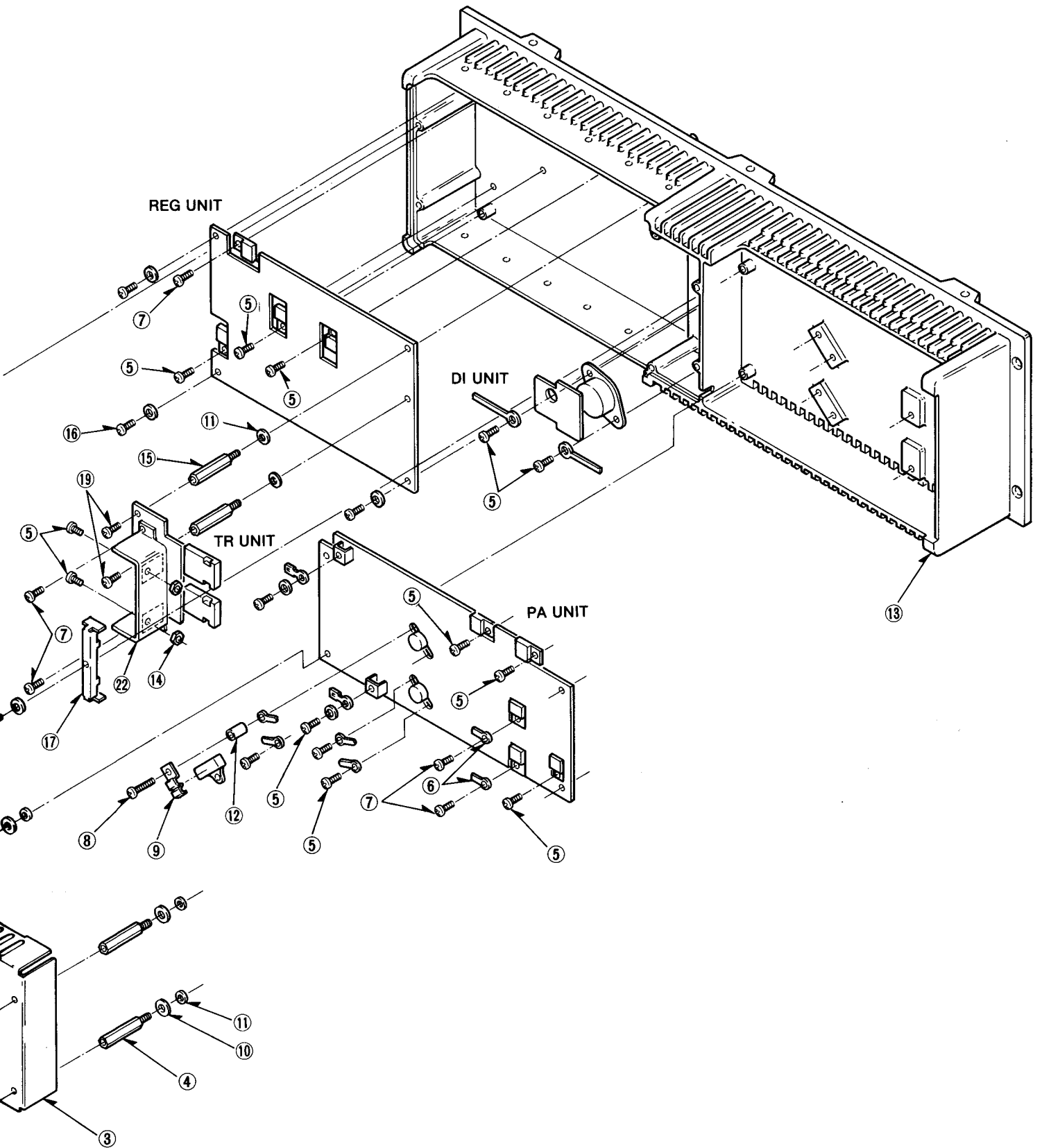

## 5-7 TUNER UNIT DISASSEMBLY

NUMBER IN DIAGRAM	DESCRIPTION	ORDERING NUMBER	QTY.
①	HLH M4 × 6	8820000520	4
②	VR plate	8930002050	2
③	G-16 gear (100)	8930005940	2
④	Thread stoper	8930000310	1
⑤	Gear plate	8930012010	1
⑥	Set screw (A) 4 × 6	8810003260	1
⑦	Tuner chassis	8010006920	1
⑧	Tuner center plate	8510004940	1
⑨	Tuner top cover	8510004850	1
⑩	Set screw (A) M2.6 × 4	8810004750	6
⑪	ICOM screw (C) 9	8810003750	4
⑫	BFO shield plate	8510000380	2
⑬	Standoff (D)	8930000070	4
⑭	Set screw (C) 3 × 6	8810003360	4
⑮	G-15 gear (20)	8930000880	1
⑯	Motor (HMK2601-01-030)	2710000080	1
⑰	OH M3 × 5	8810002160	4
⑱	OH M3 × 8	8810002180	4

**Screw type**

Screw: M2.6 × 4, M3 × 5, M3 × 8, M4 × 6

**Screw head style**

PH: Pan head, BH: button head, HLH: Headless hex hex

OH: Oval countersunk head

**Icom standard screw**

Set screw (A): Pan head screw with spring washer

Set screw (C): Pan head screw with spring and flat washers



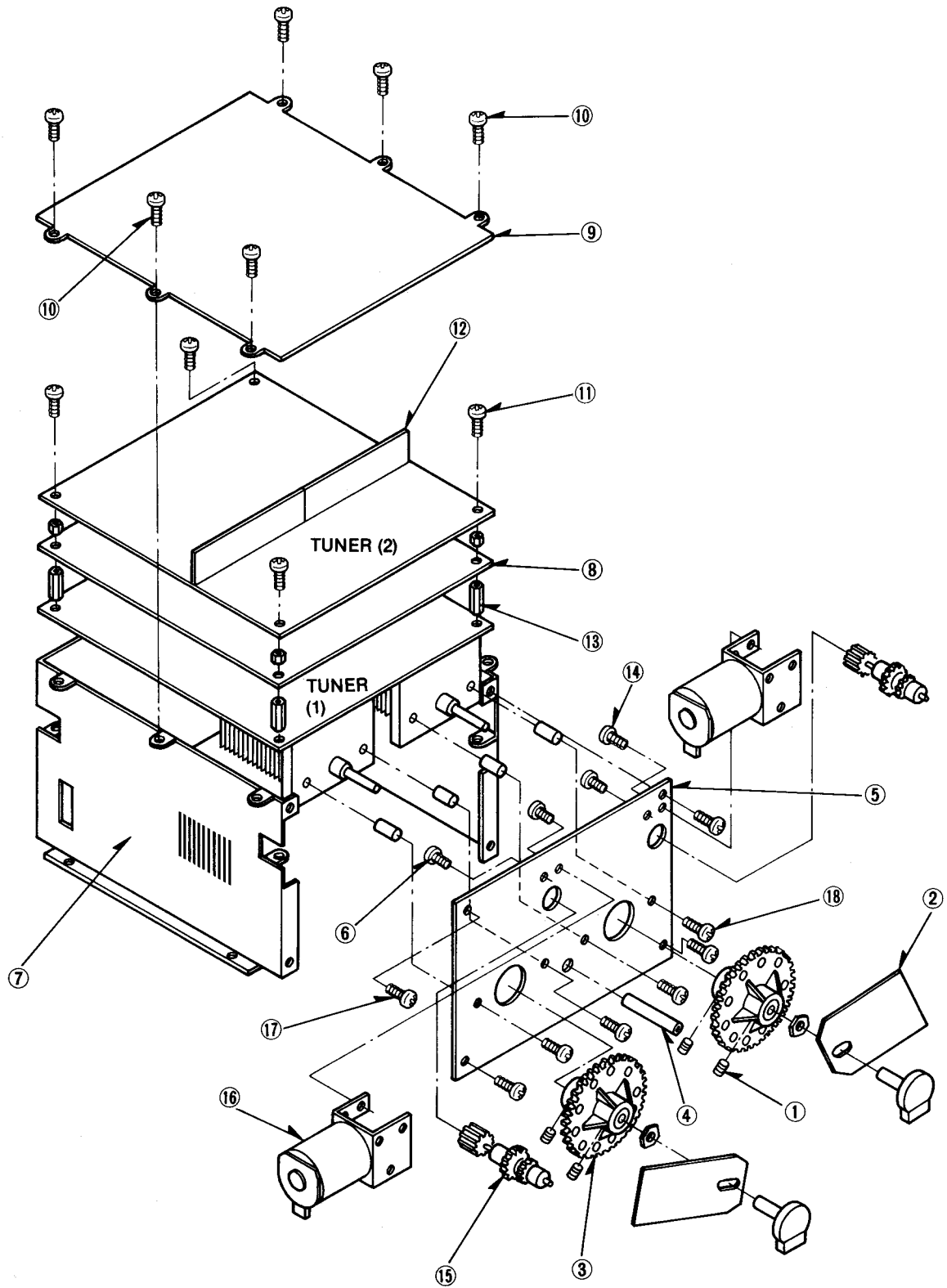

# 5-8 FRONT UNIT CONNECTOR ASSEMBLY

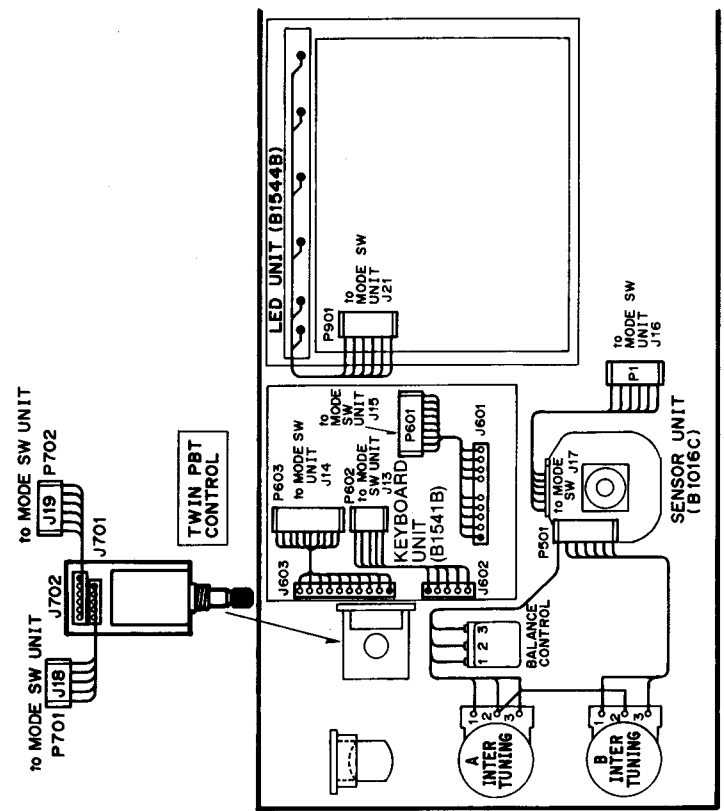
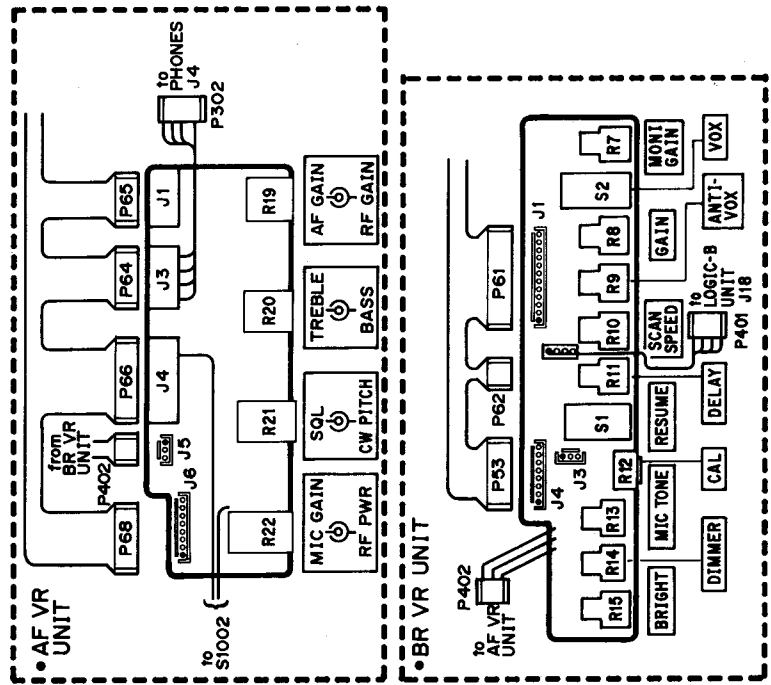
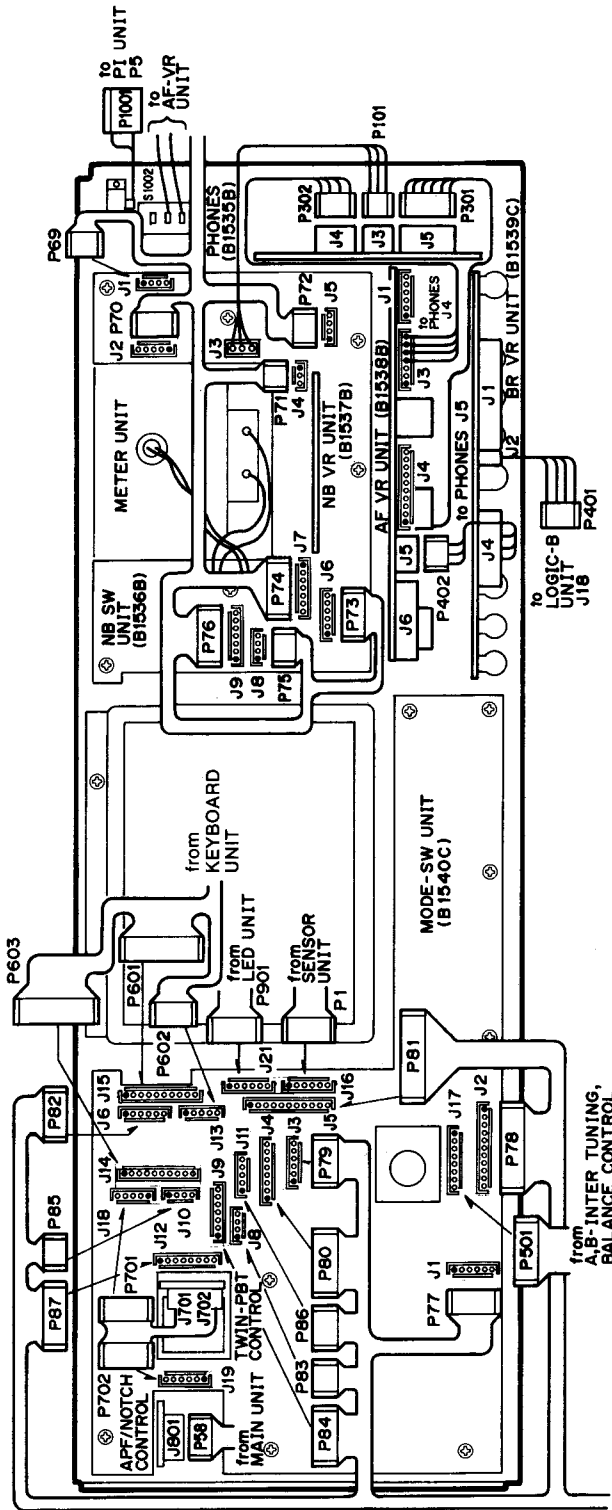

# 5-9 TOP VIEW CONNECTOR ASSEMBLY

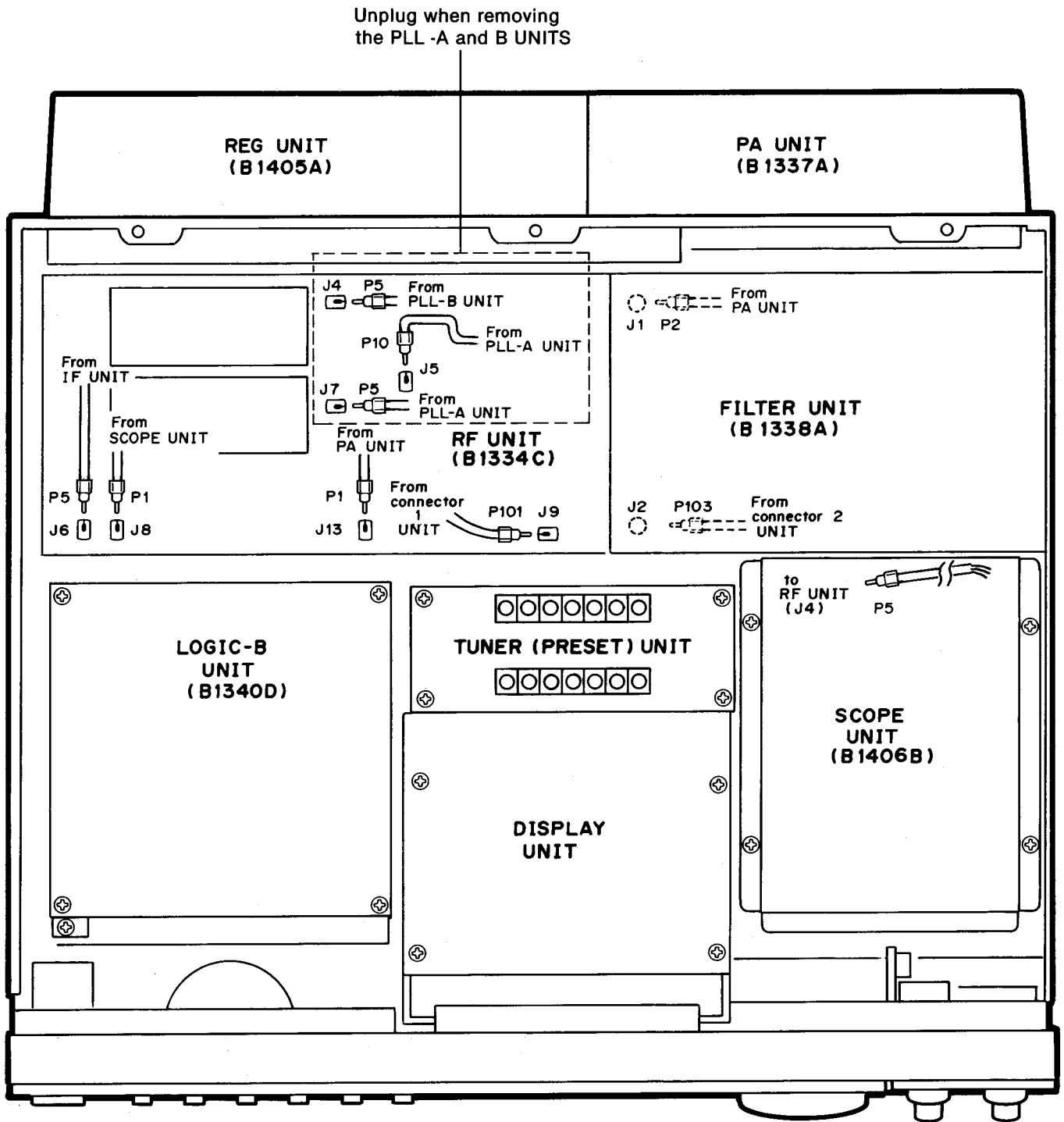

# 5-10 BOTTOM VIEW CONNECTOR ASSEMBLY

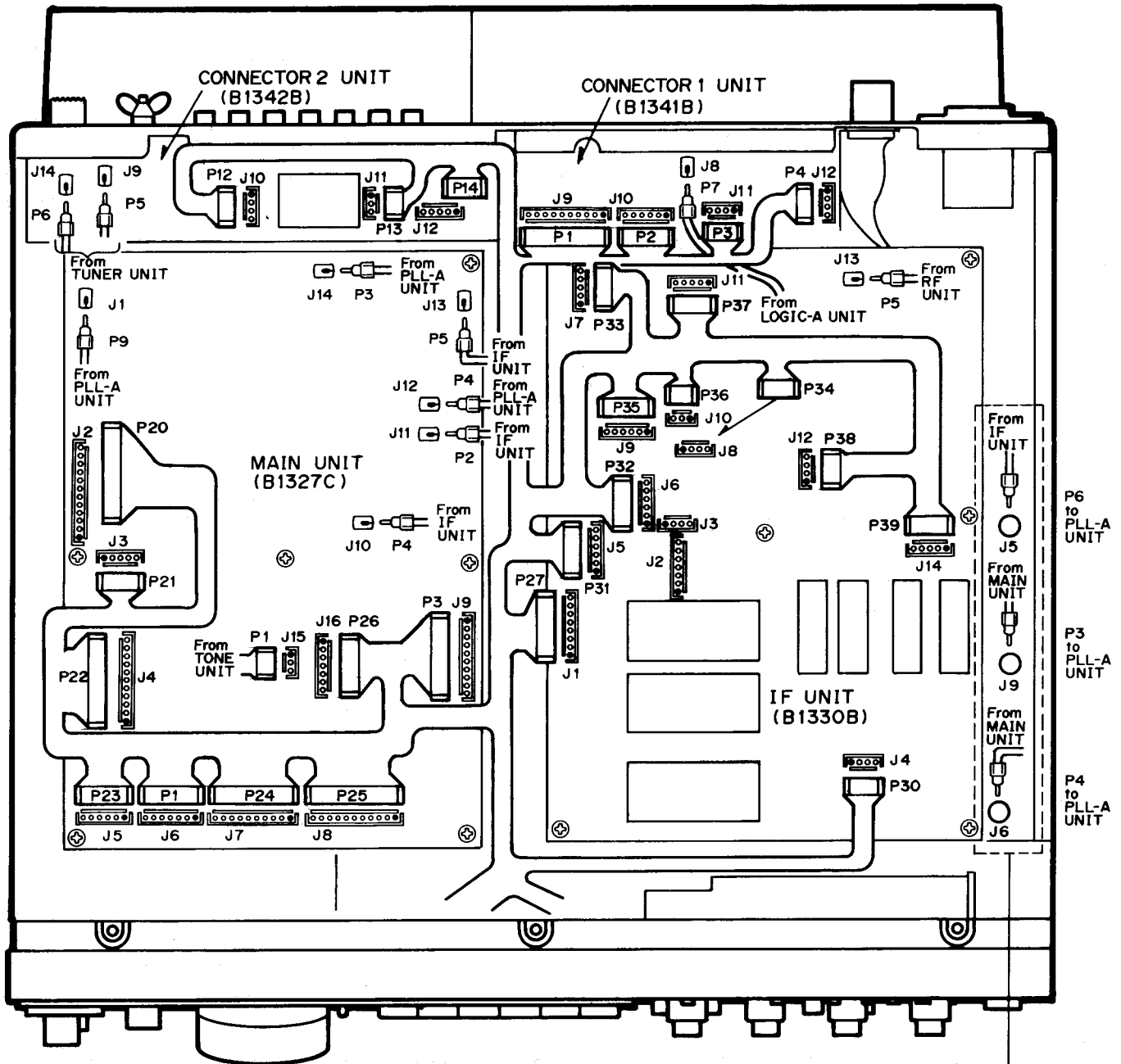

Unplug when removing the PLL-A and B UNITS

## 5-11 PLL-A AND PLL-B UNITS REMOVAL

1. Remove 14 screws from the top and bottom cover.
2. Unplug 6 coaxial cables as shown in page 5-17 and 5-18.
3. Remove 4 screws ① from the RF and FILTER UNITS and pull the unit's case as shown in Fig. 1.  
(Fig. 1 does not show the two screws on the right side.)
4. Remove 7 screws ② from the left side of the chassis.
5. Remove 3 screws ③ from the LOGIC-A bottom casing.

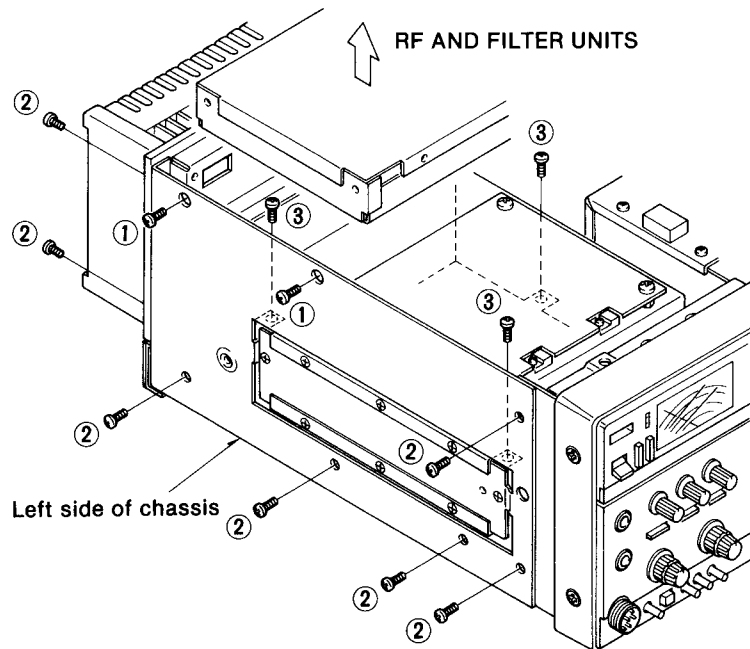

Fig. 1

6. Remove 6 screws ④ from the metal casing above the LOGIC-A UNIT and gently pull off the casing.  
Remove the connectors on the LOGIC-B UNIT.
7. Gently pull out the PLL-A, B UNITS as shown in Fig. 2.

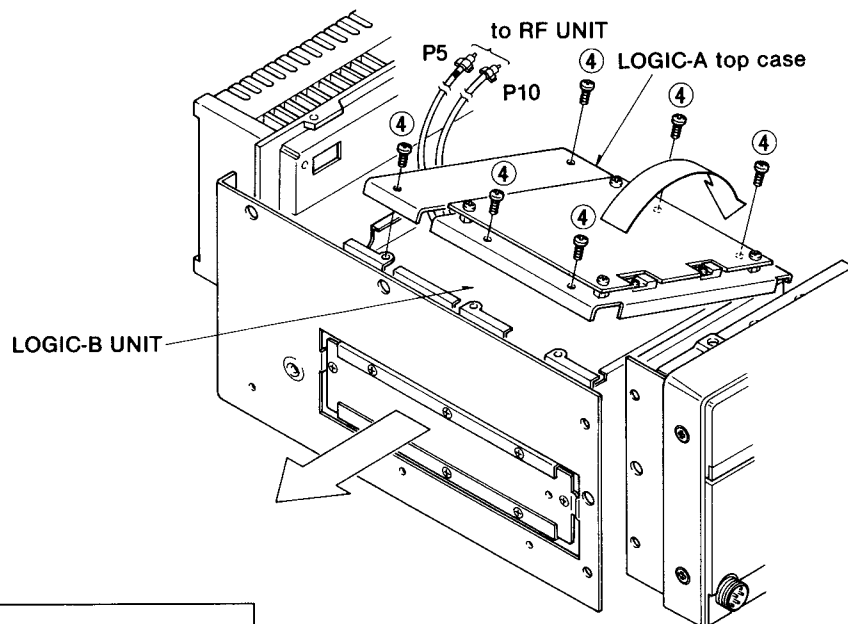

Fig. 2

### NOTE:

When reassembling these units, make sure not to pinch any of the wires between the boards and the casing.

# SECTION 6 ADJUSTMENT PROCEDURES

## 6-1 BEFORE ADJUSTMENT

### ■ POWER SUPPLY VERIFICATION

Verify output voltage of the switching regulator as shown below.

MEASUREMENT		VALUE
UNIT	POINT	
PI	J5 pin 1	15 V
	J7 pin 1	5 V
	J7 pin 8	9 V
	J4 pin 1	-9 V
	P6 pin 1	12 V
	J9 pin 1	32 V

### UNIT LOCATION

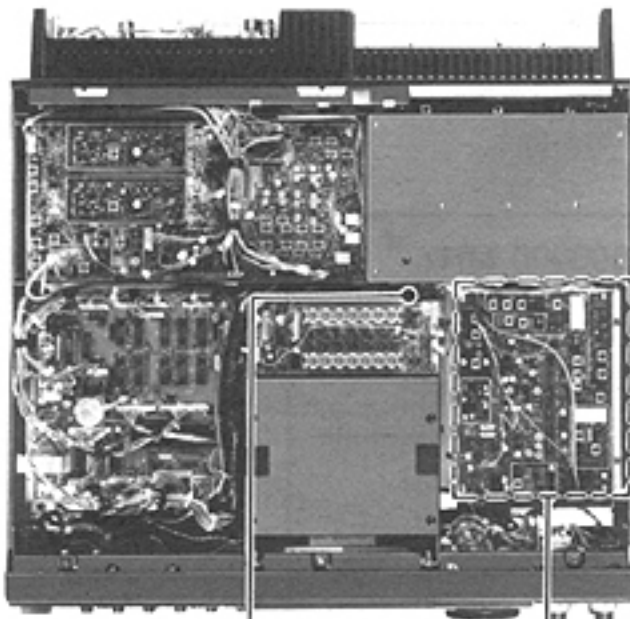

P6 12 V check point  
(See below.)

The PI UNIT is located under the SCOPE UNIT.

Pin 1 (P6), 12 V check point

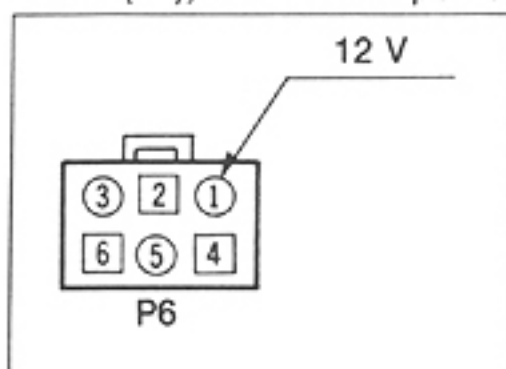

### PI UNIT

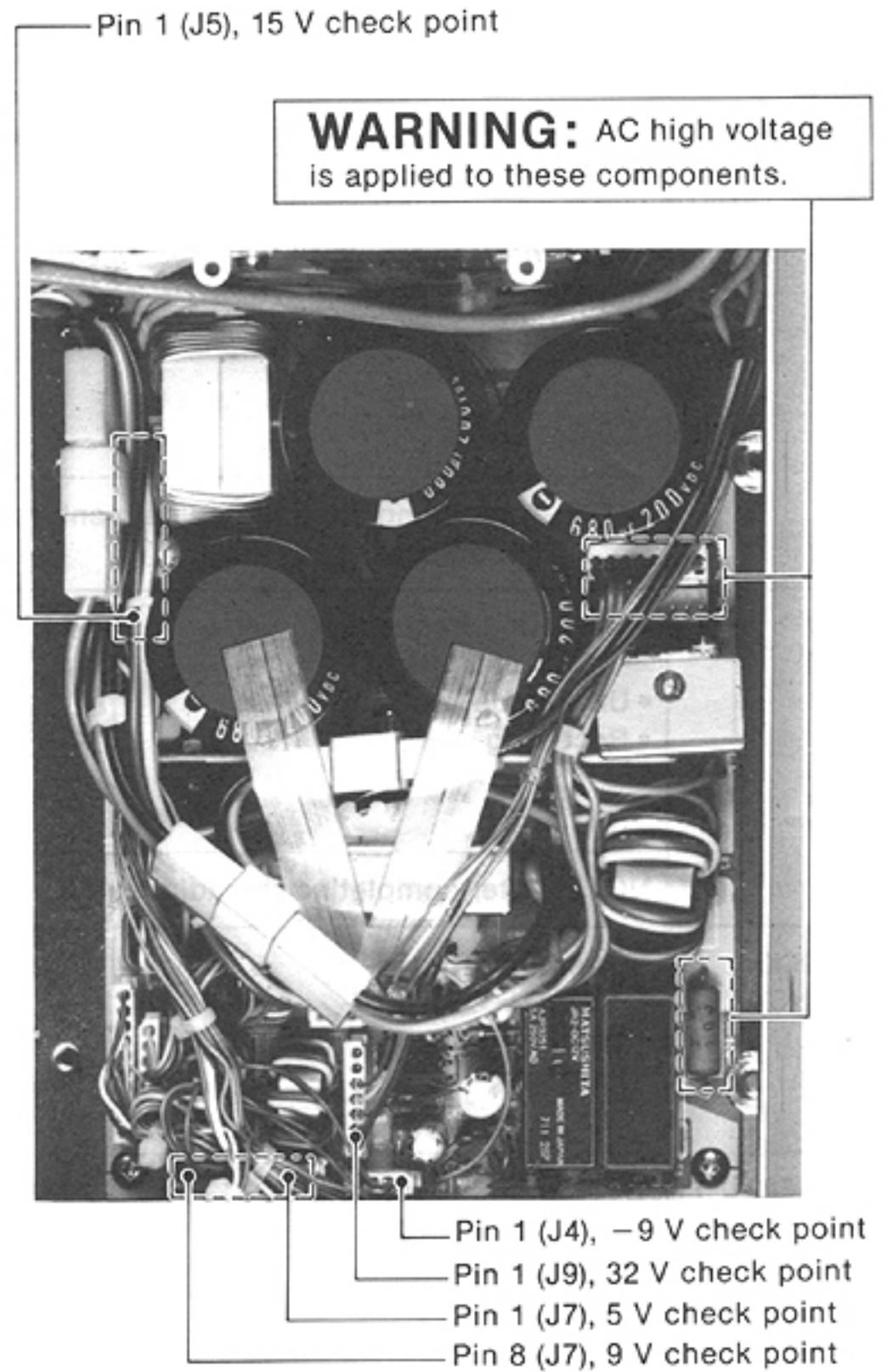

## 6-2 PLL ADJUSTMENT

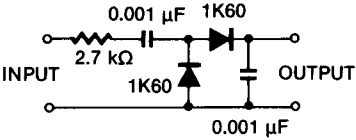
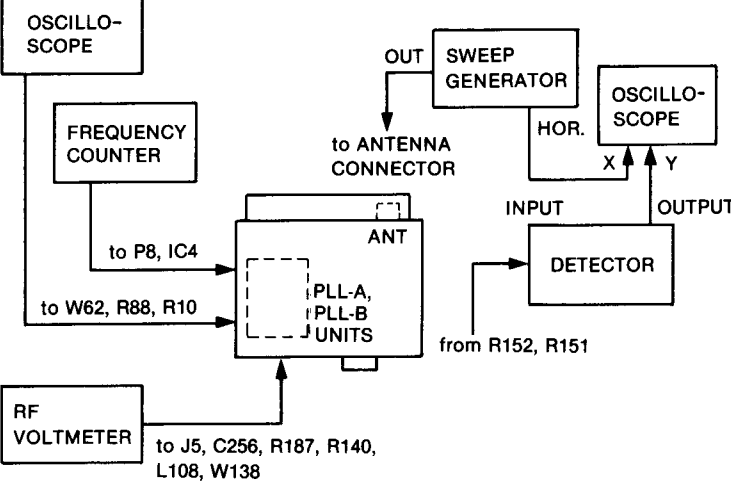
REQUIRED TEST EQUIPMENT	TEST EQUIPMENT HOOK-UP
<p>(1) FREQUENCY COUNTER</p> <ul style="list-style-type: none"> <li>• Frequency range : 0.1~100 MHz</li> <li>• Frequency accuracy : <math>\pm 0.1</math> ppm or better</li> <li>• Sensitivity : 100 mV or better</li> </ul> <p>(2) RF VOLTMETER</p> <ul style="list-style-type: none"> <li>• Frequency range : 0.1~100 MHz</li> <li>• Measuring range : 0.01~10 V</li> </ul> <p>(3) OSCILLOSCOPE</p> <ul style="list-style-type: none"> <li>• Frequency range : DC~50 MHz</li> <li>• Measuring range : 0.01~10 V</li> </ul> <p>(4) SWEEP GENERATOR</p> <ul style="list-style-type: none"> <li>• Frequency range : 0.1~100 MHz</li> <li>• Sweep bandwidth : At least 10 MHz</li> <li>• Output impedance : 50 <math>\Omega</math></li> </ul> <p>(5) DETECTOR</p> 	

ADJUSTMENT	ADJUSTMENT CONDITIONS	MEASUREMENT		VALUE	ADJUSTMENT POINT	
		UNIT	LOCATION		UNIT	ADJUST
REFERENCE FREQUENCY	<ul style="list-style-type: none"> <li>• Operating frequency: 14.17500 MHz</li> <li>• USB mode</li> <li>• Receiving</li> <li>• Open the top cover of X1.</li> </ul>	PLL-A	Connect the oscilloscope to W62.	2 V DC	Front panel	[CAL] pot
			Connect the frequency counter to P8.	12.500000 MHz	PLL-A	X1
NOTE: After completing the adjustment, return P8 and X1 top cover to their original conditions.						
2ND LO OUTPUT LEVEL	<ul style="list-style-type: none"> <li>• Operating frequency: 14.17500 MHz</li> <li>• USB mode</li> <li>• Receiving</li> </ul>	PLL-A	Terminate J5 to ground with a 50 $\Omega$ resistor. Connect the RF voltmeter to J5.	Adjust for maximum output. (-8~-12 dBm)	PLL-A	L80, L81
		NOTE: After completing the adjustment, remove the resistor from J5.				
DDS CLOCK FREQUENCY	<ul style="list-style-type: none"> <li>• Operating frequency: 14.17500 MHz</li> <li>• USB mode</li> <li>• Receiving</li> </ul>	DDS-A	Connect the frequency counter to IC4, pin 11.	5.242880 MHz	DDS-A	C1
MULTIPLIER OUTPUT LEVEL	<ul style="list-style-type: none"> <li>• Operating frequency: 14.17500 MHz</li> <li>• USB mode</li> <li>• Receiving</li> </ul>	PLL-A	Connect the RF voltmeter to C256.	Adjust for maximum output. (approx. 300 mVp-p, approx. 106 mVrms)	PLL-A	L98, L97, L96, L95
PLOA AMP OUTPUT LEVEL	<ul style="list-style-type: none"> <li>• Operating frequency: 14.17500 MHz</li> <li>• USB mode</li> <li>• Receiving</li> </ul>	PLL-A	Connect the RF voltmeter to R187.	Adjust for maximum output. (approx. 250 mVp-p, approx. 88 mVrms)	PLL-A	L104

**PLL-A AND DDS-A UNITS**

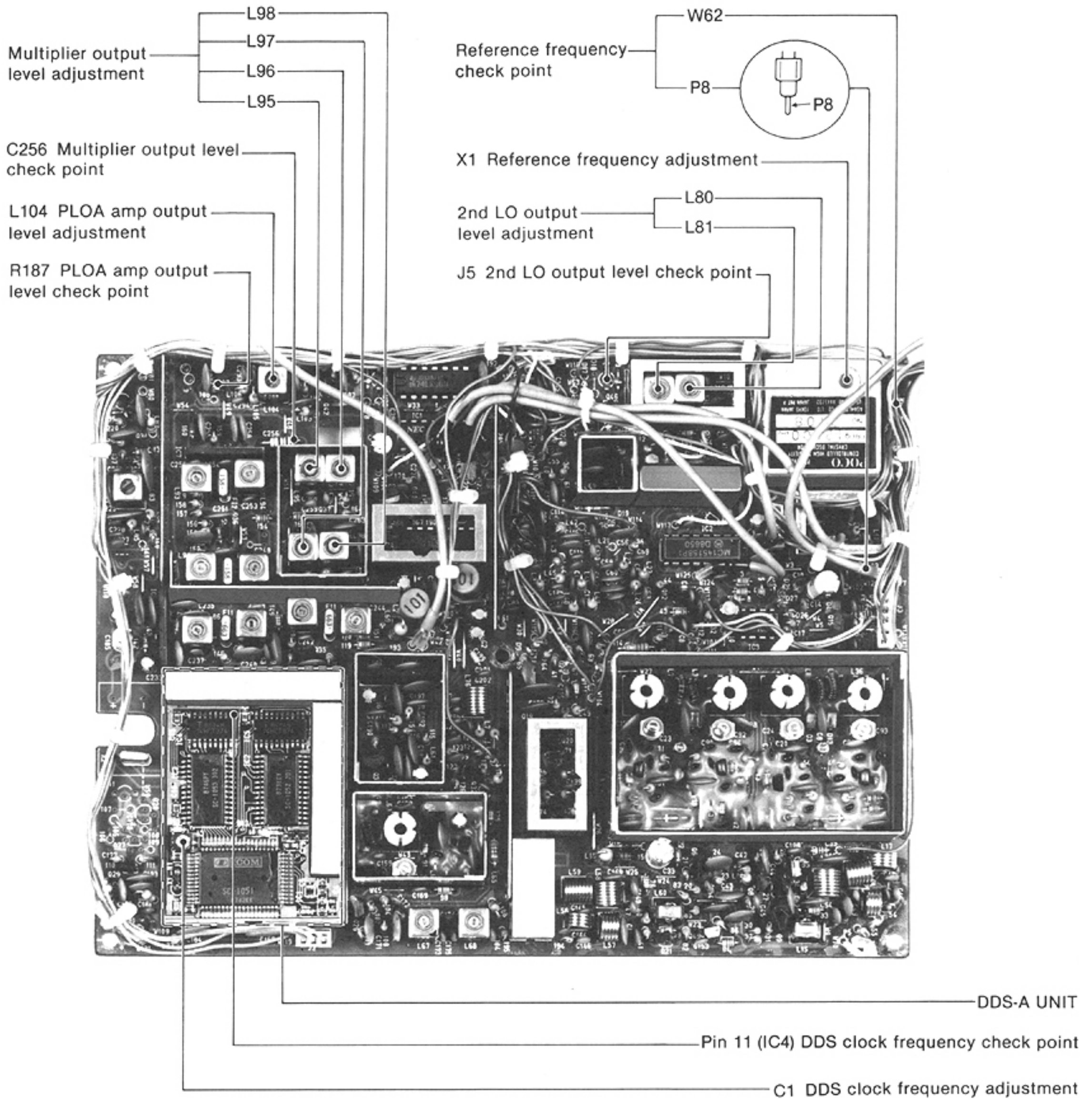

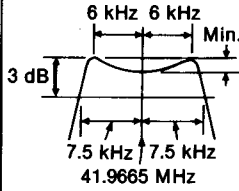
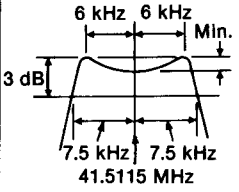

## PLL ADJUSTMENT (CONTINUED)

ADJUSTMENT	ADJUSTMENT CONDITIONS	MEASUREMENT		VALUE	ADJUSTMENT POINT		
		UNIT	LOCATION		UNIT	ADJUST	
41.9665 MHz AMP BANDWIDTH	<ul style="list-style-type: none"> <li>• Operating frequency: 14.17500 MHz</li> <li>• USB mode</li> <li>• Unsolder land between C254 and L94. (See p. 6-5.)</li> <li>• Apply an RF sweep signal to land of L94 via 330 Ω resistor. Sweep level: -25 dBm (13 mV) Center frequency: 41.9665 MHz Sweep bandwidth: 30 kHz</li> </ul>	PLL-A	Connect the oscilloscope to R152 via the detector.	Adjust as follows: 	PLL-A	L94, L93, L92, L91	
							NOTE: After above adjustment, turn [POWER] switch OFF. Re-solder land between C254 and L94.
PLOB AMP OUTPUT LEVEL	<ul style="list-style-type: none"> <li>• Operating frequency: 14.17500 MHz</li> <li>• USB mode</li> <li>• Receiving</li> </ul>	PLL-A	Connect the RF voltmeter to R140.	Adjust for maximum output. (approx. 60 mVp-p, approx. 21 mVrms)	PLL-A	L83	
41.5115 MHz AMP BANDWIDTH	<ul style="list-style-type: none"> <li>• Operating frequency: 14.17500 MHz</li> <li>• USB mode</li> <li>• Unsolder land between R144 and IC6 pin 3. (See p. 6-5.)</li> <li>• Ground P7 to chassis.</li> <li>• Apply an RF sweep signal to R144. Sweep level: -25 dBm (13 mV) Center frequency: 41.5115 MHz Sweep bandwidth: 30 kHz</li> </ul>	PLL-A	Connect the oscilloscope to R151 via the detector.	Adjust as follows: 	PLL-A	L86, L87, L88, L89	
							NOTE: After above adjustment, turn [POWER] switch OFF. Re-solder land between R144 and IC6 pin 3. Return P7 to its original condition.
LPL LOOP (PLL-A)	<ul style="list-style-type: none"> <li>• Operating frequency: 14.00000 MHz</li> <li>• USB mode</li> <li>• Receiving</li> </ul>	PLL-A	Connect the oscilloscope to R88.	1.2 V DC	PLL-A	C160	
	<ul style="list-style-type: none"> <li>• Operating frequency: 14.00000 MHz, 13.99999 MHz</li> </ul>		Connect the RF voltmeter to L108.	Adjust for maximum output. (approx. 140 mVp-p)			L67, L68
	NOTE: In above adjustment 2, adjust to the same output level on both frequencies.						
HPL LOOP (PLL-A)	<ul style="list-style-type: none"> <li>• Operating frequency: 0.10000 MHz</li> <li>• LSB mode</li> <li>• Receiving</li> </ul>	PLL-A	Connect the oscilloscope to R10.	2.0 V DC	PLL-A	C23	
	<ul style="list-style-type: none"> <li>• Operating frequency: 7.99999 MHz</li> </ul>			6~7 V DC		Verify	
	<ul style="list-style-type: none"> <li>• Operating frequency: 8.00000 MHz</li> <li>• USB mode</li> </ul>			3.0 V DC		C24	
	<ul style="list-style-type: none"> <li>• Operating frequency: 15.00000 MHz</li> </ul>			3.0 V DC		C92	
	<ul style="list-style-type: none"> <li>• Operating frequency: 22.00000 MHz</li> </ul>			2.5 V DC		C93	
	<ul style="list-style-type: none"> <li>• Operating frequency: 14.99999 MHz, 21.99999 MHz, 30.00000 MHz</li> </ul>			6~7 V DC on each frequency		Verify	

# PLL-A UNIT

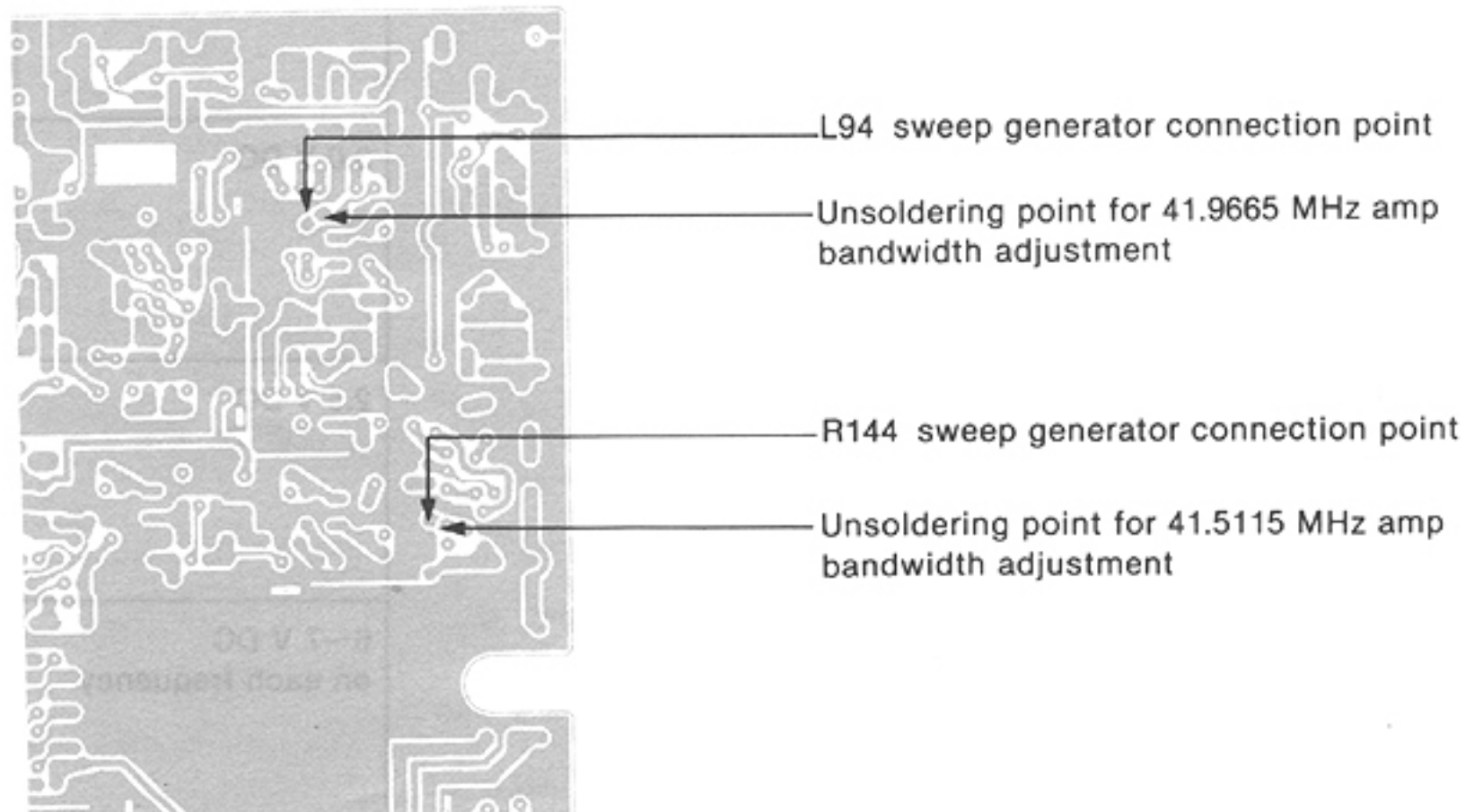
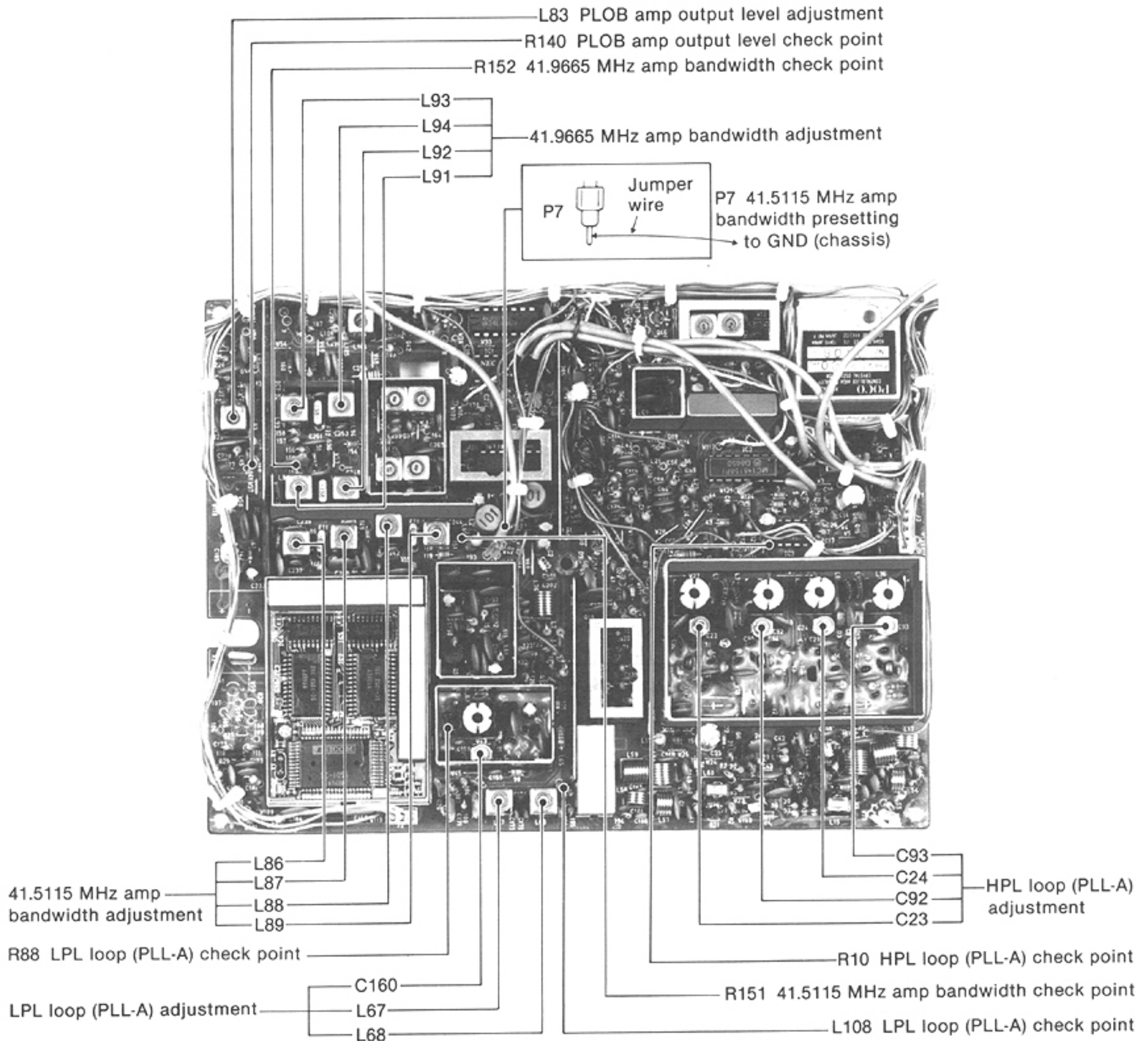

PLL-A UNIT FOIL SIDE

## PLL ADJUSTMENT (CONTINUED)

ADJUSTMENT	ADJUSTMENT CONDITIONS	MEASUREMENT		VALUE	ADJUSTMENT POINT		
		UNIT	LOCATION		UNIT	ADJUST	
LPLO AMP OUTPUT LEVEL	1	<ul style="list-style-type: none"> <li>• Operating frequency: 14.17500 MHz</li> <li>• USB mode</li> <li>• Receiving</li> </ul>	PLL-B	Connect the RF voltmeter to W138.	Adjust for maximum output. (approx. 310 mVp-p, approx. 109 mVrms)	PLL-B	L104
LPL LOOP (PLL-B)	1	<ul style="list-style-type: none"> <li>• Operating frequency ("B" section): 14.00000 MHz</li> <li>• USB mode</li> <li>• [DUAL WATCH] switch: ON</li> </ul>	PLL-B	Connect the oscilloscope to R88.	1.2 V DC	PLL-B	C160
	2	<ul style="list-style-type: none"> <li>• Operating frequency ("B" section): 14.00000 MHz, 13.99999 MHz</li> </ul>		Connect the RF voltmeter to L108.	Adjust for maximum output. (approx. 140 mVp-p)		
	NOTE: In above adjustment 2, adjust to the same output level on both frequencies.						
HPL LOOP (PLL-B)	1	<ul style="list-style-type: none"> <li>• Operating frequency ("B" section): 0.10000 MHz</li> <li>• LSB mode</li> <li>• [DUAL WATCH] switch: ON</li> </ul>	PLL-B	Connect the oscilloscope to R10.	2.0 V DC	PLL-B	C23
	2	<ul style="list-style-type: none"> <li>• Operating frequency ("B" section): 7.99999 MHz</li> </ul>			6~7 V DC		Verify
	3	<ul style="list-style-type: none"> <li>• Operating frequency ("B" section): 8.00000 MHz</li> <li>• USB mode</li> </ul>			3.0 V DC		C24
	4	<ul style="list-style-type: none"> <li>• Operating frequency ("B" section): 15.00000 MHz</li> </ul>			3.0 V DC		C92
	5	<ul style="list-style-type: none"> <li>• Operating frequency ("B" section): 22.00000 MHz</li> </ul>			2.5 V DC		C93
	6	<ul style="list-style-type: none"> <li>• Operating frequency ("B" section): 14.99999 MHz, 21.99999 MHz, 30.00000 MHz</li> </ul>			6~7 V DC on each frequency		Verify

# PLL-B UNIT

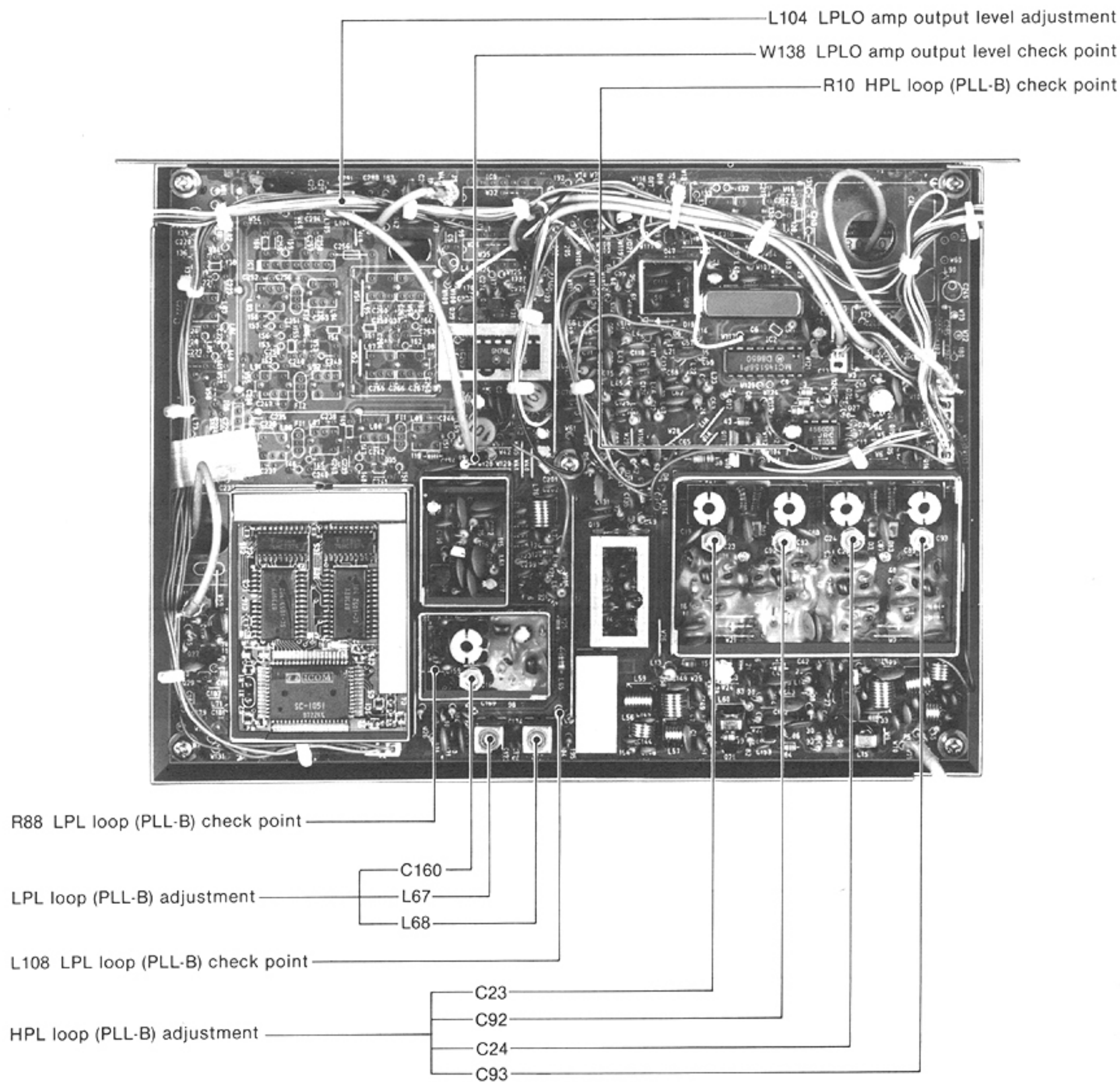

## 6-3 FREQUENCY ADJUSTMENT

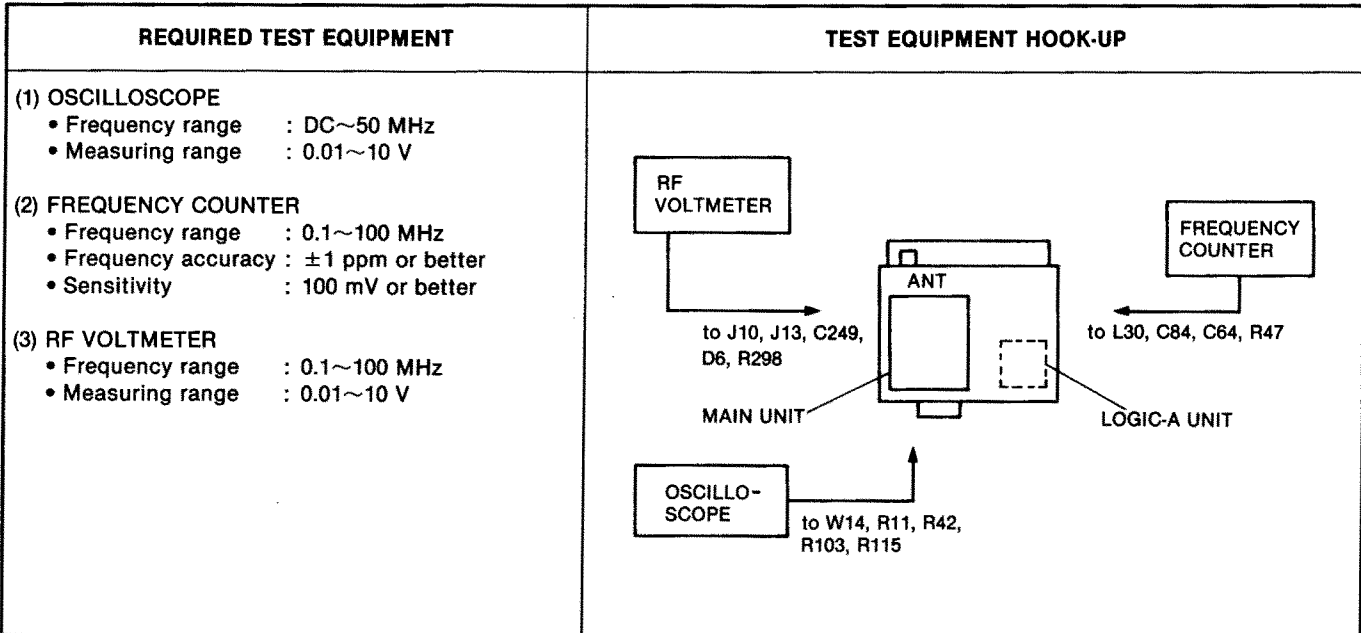

ADJUSTMENT	ADJUSTMENT CONDITIONS	MEASUREMENT		VALUE	ADJUSTMENT POINT	
		UNIT	LOCATION		UNIT	ADJUST
REFA AMP OUTPUT LEVEL	1 <ul style="list-style-type: none"> <li>• Operating frequency: 14.17500 MHz</li> <li>• USB mode</li> <li>• Receiving</li> </ul>	MAIN	Connect the oscilloscope to W14.	Adjust for maximum output.	MAIN	L1
PBT-1 LOCK VOLTAGE	1 <ul style="list-style-type: none"> <li>• AM mode</li> <li>• [TWIN PBT] controls: Center</li> <li>• Receiving</li> </ul>	MAIN	Connect the oscilloscope to R11.	2.5 V DC	MAIN	L2
PBT-2 LOCK VOLTAGE	1 <ul style="list-style-type: none"> <li>• AM mode</li> <li>• [TWIN PBT] controls: Center</li> <li>• Receiving</li> </ul>	MAIN	Connect the oscilloscope to R42.	2.5 V DC	MAIN	L14
BFO	1 <ul style="list-style-type: none"> <li>• CW mode</li> <li>• Receiving</li> </ul>	MAIN	Connect the oscilloscope to R103.	2.5 V DC	MAIN	L37
	2 <ul style="list-style-type: none"> <li>• AM mode</li> </ul>		Connect the frequency counter to L30.	455.00 kHz		L36
	3 <ul style="list-style-type: none"> <li>• USB mode</li> </ul>			453.50 kHz		C106
	4 <ul style="list-style-type: none"> <li>• LSB mode</li> </ul>			456.50 kHz		C107
NOTCH OSCILLATOR	1 <ul style="list-style-type: none"> <li>• USB mode</li> <li>• [NOTCH] control: Center</li> <li>• Receiving</li> </ul>	MAIN	Connect the frequency counter to C84.	12.4000 MHz	MAIN	L18
PITCH CONTROL	1 <ul style="list-style-type: none"> <li>• CW mode</li> <li>• [CW PITCH] control: Center</li> <li>• Receiving</li> </ul>	MAIN	Connect the frequency counter to C64.	1.25070 MHz	MAIN	L44
FM TX OSCILLATOR	1 <ul style="list-style-type: none"> <li>• Operating frequency: 14.17500 MHz</li> <li>• FM mode</li> <li>• Transmitting</li> </ul>	MAIN	Connect the oscilloscope to R115.	2.5 V DC	MAIN	L41
	2 <ul style="list-style-type: none"> <li>• Unplug P4 from J10.</li> </ul>		Terminate J10 to ground with a 50 $\Omega$ resistor. Connect the RF voltmeter to J10.	Adjust for maximum output.		L31, L35
NOTE: After completing the adjustment, remove the resistor from J10, then plug P4.						



# MAIN UNIT

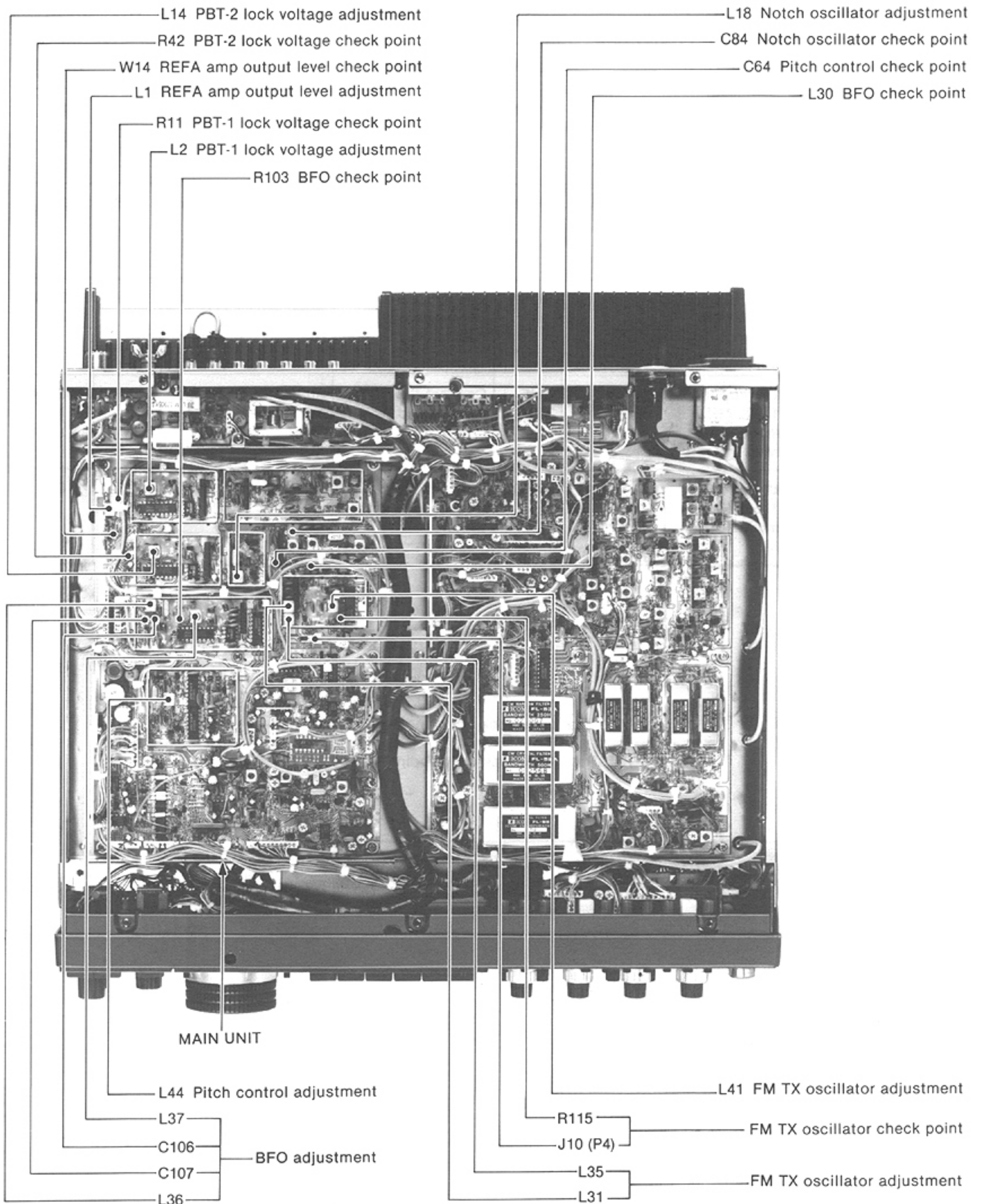

## FREQUENCY ADJUSTMENT (CONTINUED)

ADJUSTMENT	ADJUSTMENT CONDITIONS	MEASUREMENT		VALUE	ADJUSTMENT POINT	
		UNIT	LOCATION		UNIT	ADJUST
PBC OUTPUT LEVEL	1 <ul style="list-style-type: none"> <li>• Operating frequency: 14.17500 MHz</li> <li>• USB mode</li> <li>• Receiving</li> </ul>	MAIN	Connect the RF voltmeter to J13.	Adjust for maximum output.	MAIN	L11
11.15 MHz OUTPUT LEVEL	1 <ul style="list-style-type: none"> <li>• Operating frequency: 14.17500 MHz</li> <li>• USB mode</li> <li>• Receiving</li> </ul>	MAIN	Connect the RF voltmeter to C249.	Adjust for maximum output.	MAIN	L25
BFO OUTPUT LEVEL	1 <ul style="list-style-type: none"> <li>• Operating frequency: 14.17500 MHz</li> <li>• USB mode</li> <li>• Receiving</li> </ul>	MAIN	Connect the RF voltmeter to D6 cathode.	Adjust for maximum output. (700~1000 mVp-p)	MAIN	L22, L23, L27
2LO AMP OUTPUT LEVEL	1 <ul style="list-style-type: none"> <li>• Operating frequency: 14.17500 MHz</li> <li>• USB mode</li> <li>• Receiving</li> </ul>	IF	Connect the RF voltmeter to R298.	Adjust for maximum output. (0~+4 dBm)	IF	L39, L40
REAL TIME CLOCK	1 <ul style="list-style-type: none"> <li>• Operating frequency: 14.17500 MHz</li> <li>• USB mode</li> <li>• Receiving</li> </ul>	LOGIC-A	Connect the frequency counter to R47.	16384 Hz	LOGIC-A	C17

## LOGIC-A UNIT

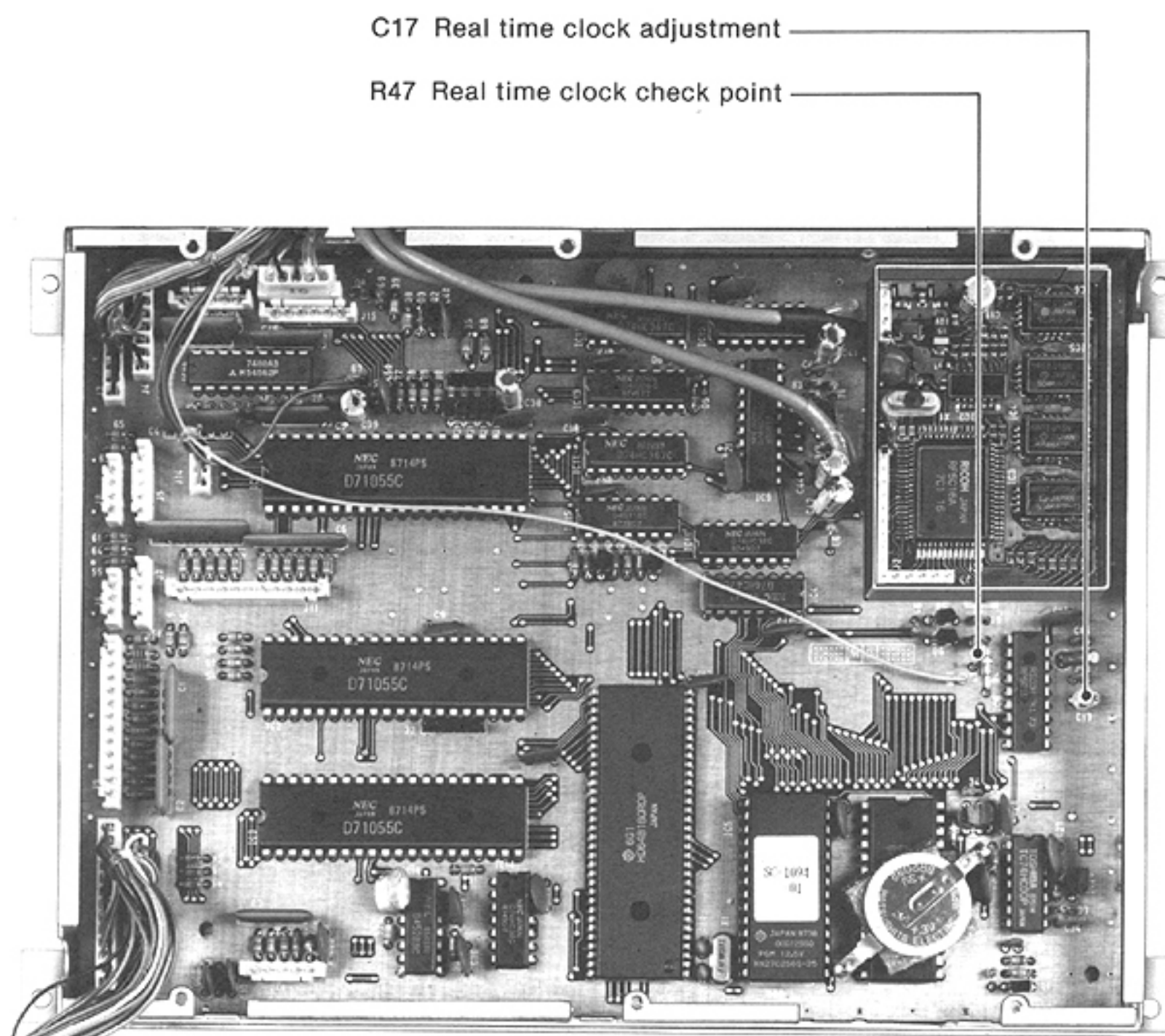



# MAIN AND IF UNITS

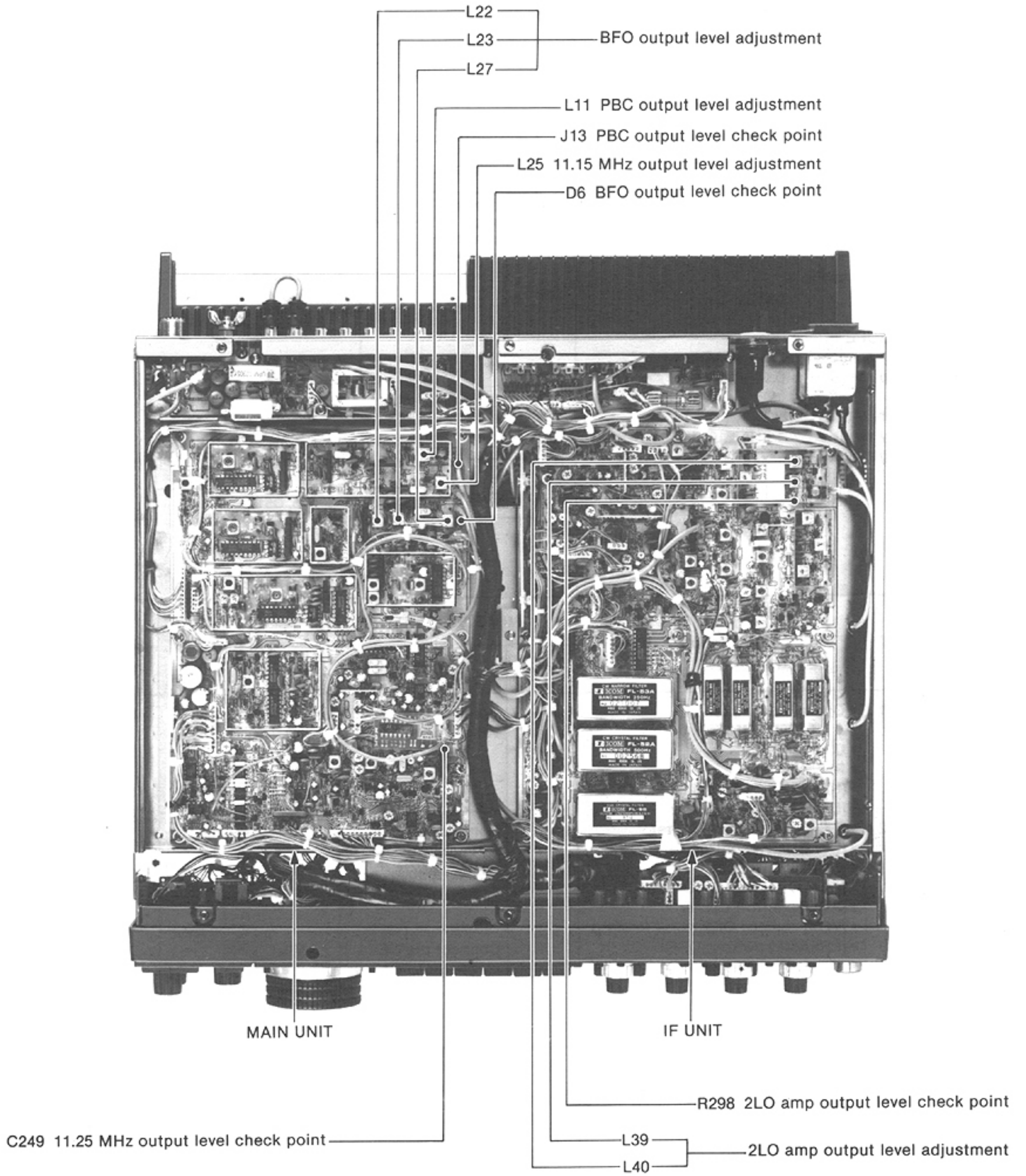



## 6-4 RECEIVER ADJUSTMENT

REQUIRED TEST EQUIPMENT	TEST EQUIPMENT HOOK-UP
<p>(1) STANDARD SIGNAL GENERATOR (SSG)</p> <ul style="list-style-type: none"> <li>• Frequency range : 0.1~50 MHz</li> <li>• Output level : -127~-17 dBm (0.1 <math>\mu</math>V~32 mV)</li> </ul> <p>(2) DC VOLTMETER</p> <ul style="list-style-type: none"> <li>• Input impedance : 50 k<math>\Omega</math>/DC or better</li> </ul> <p>(3) AC MILLI-VOLTMETER</p> <ul style="list-style-type: none"> <li>• Measuring range : 10 mV~10 V</li> </ul> <p>(4) EXTERNAL SPEAKER</p> <ul style="list-style-type: none"> <li>• Impedance : 8 <math>\Omega</math></li> </ul> <p>(5) OSCILLOSCOPE</p> <ul style="list-style-type: none"> <li>• Frequency range : DC~50 MHz</li> <li>• Measuring range : 0.01~10 V</li> </ul> <p>(6) DISTORTION METER</p> <ul style="list-style-type: none"> <li>• Frequency range : 1 kHz<math>\pm</math>10 Hz</li> <li>• Measuring range : 1~10 %</li> </ul>	

ADJUSTMENT	ADJUSTMENT CONDITIONS	MEASUREMENT		VALUE	ADJUSTMENT POINT	
		UNIT	LOCATION		UNIT	ADJUST
IF AMP	<ul style="list-style-type: none"> <li>• Operating frequency: 14.17500 MHz</li> <li>• USB mode</li> <li>• Receiving</li> <li>• [RF GAIN] control: Max. CW*</li> <li>• [BASS] control: Center</li> <li>• [TREBLE] control: Center</li> <li>• [CW PITCH] control: Center</li> <li>• [NB] switch: OFF</li> <li>• [AGC OFF] switch: OFF (OUT)</li> <li>• [AGC] control: Center</li> <li>• [VOX] switch: OFF</li> <li>• [PREAMP] switch: OFF</li> <li>• Attenuator switches: OFF</li> <li>• [MARKER] switch: OFF</li> <li>• Filter switches: WIDE</li> <li>• [NOTCH] switch: OFF</li> <li>• [TWIN PBT] controls: Center</li> <li>• [RIT] switch: OFF</li> <li>• [DUAL WATCH] switch: OFF</li> </ul>	MAIN	Connect the DC voltmeter to W113.	3.9 V	MAIN	R308
			Connect the DC voltmeter to Q44 source.	2.3 V		R264
			Connect the DC voltmeter to Q45 source.	2.3 V		R267
		IF	Connect the DC voltmeter to Q51 source.	2.3 V	IF	R186
			Connect the DC voltmeter to Q57 source.	2.3 V		R250
	6	• [AGC OFF] switch: ON (IN position)	RF	Connect the DC voltmeter to Q11 emitter.	2.5 V	RF

\*CW: Clockwise

**MAIN AND IF UNITS**

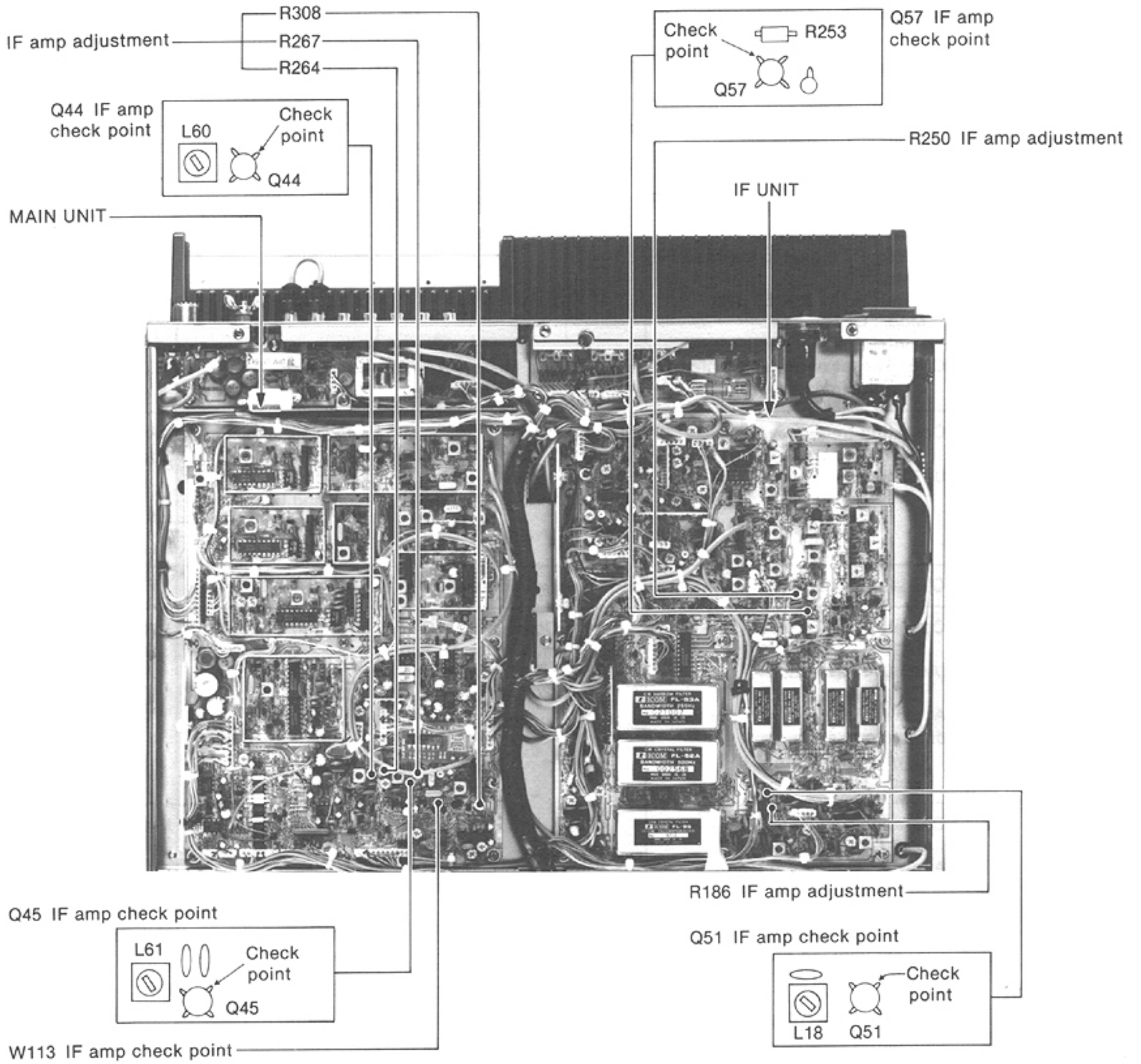

**RF UNIT**

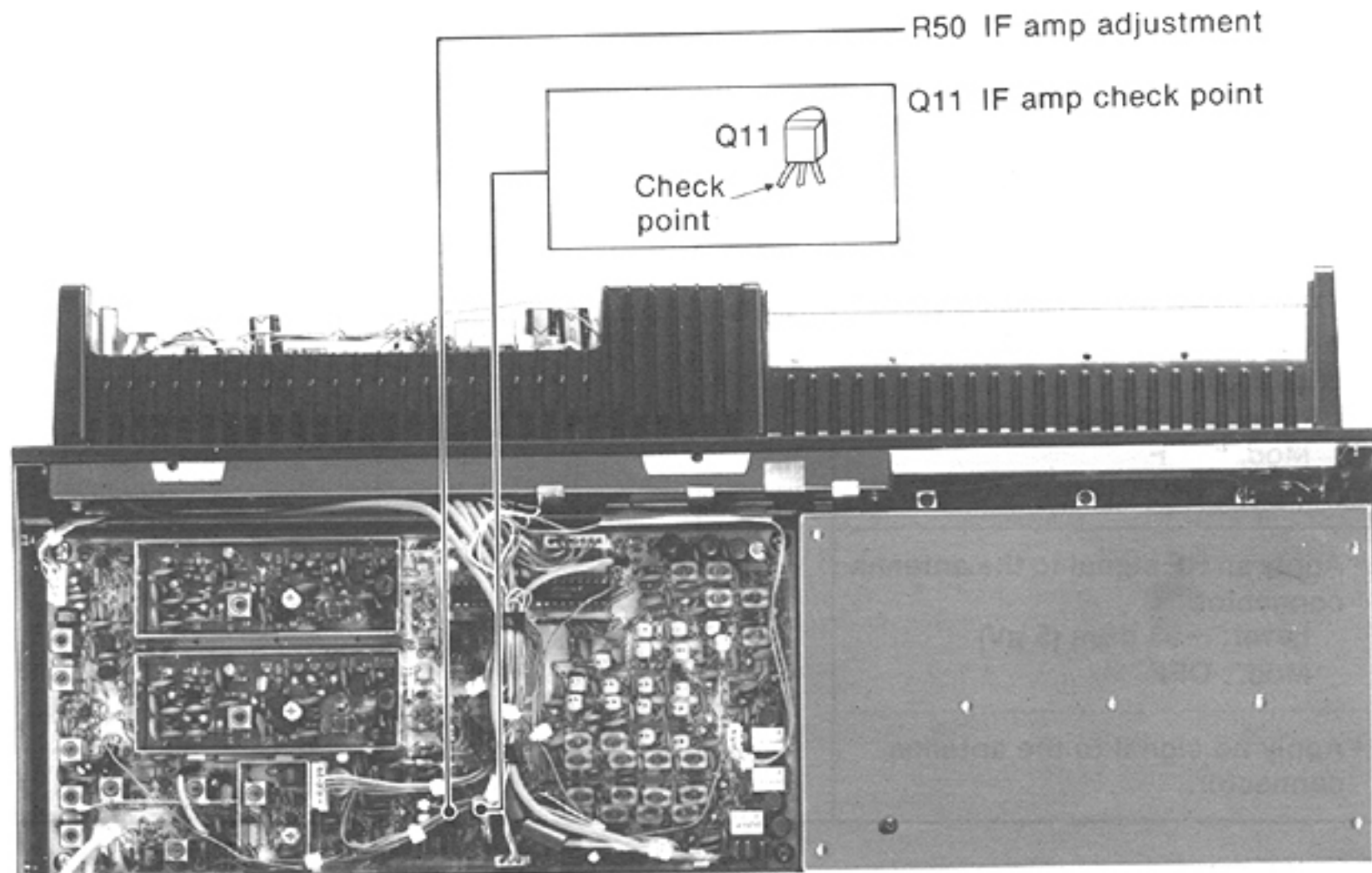

## RECEIVER ADJUSTMENT (CONTINUED)

ADJUSTMENT	ADJUSTMENT CONDITIONS	MEASUREMENT		VALUE	ADJUSTMENT POINT		
		UNIT	LOCATION		UNIT	ADJUST	
IF FILTER	1	<ul style="list-style-type: none"> <li>Operating frequency: 14.17500 MHz</li> <li>AM mode</li> <li>Filter switches: NAR</li> <li>S2 AM filter switch: OFF</li> </ul>	Front panel	S-meter	Adjust for minimum meter movement keeping within receiving band.	Front panel	Main dial
	2	<ul style="list-style-type: none"> <li>Apply an RF signal to the antenna connector.</li> <li>Level: -73 dBm (50 <math>\mu</math>V)</li> <li>Mod.: OFF</li> </ul>			Maximum		
	NOTE: Repeat above adjustments 1 and 2 several times. After completing the adjustment, return S2 to its ON position.						
	3	<ul style="list-style-type: none"> <li>Operating frequency: 14.17500 MHz</li> <li>USB mode</li> </ul>	Front panel	S-meter	Adjust for minimum meter movement keeping within receiving band.	Front panel	Main dial
4		Maximum			IF		
NOTE: Repeat above adjustments 3 and 4 several times.							
RECEIVER GAIN	1	<ul style="list-style-type: none"> <li>Operating frequency: 14.10000 MHz</li> <li>[AGC OFF] switch: ON (IN position)</li> <li>Apply an RF signal to the antenna connector.</li> <li>Level: -107 dBm (1 <math>\mu</math>V)</li> <li>Mod.: OFF</li> </ul>	Rear panel	Connect the AC milli-voltmeter with an 8 $\Omega$ load to the EXT. SP jack.	Max. audio output	MIXER A	L306
	2	<ul style="list-style-type: none"> <li>Operating frequency: 0.10000 MHz</li> <li>Apply no signal to the antenna connector.</li> </ul>			Min. noise output	MIXER A	R322
	3	<ul style="list-style-type: none"> <li>Operating frequency ("B" section): 14.10000 MHz</li> <li>[DUAL WATCH] switch: ON</li> <li>[BALANCE] control: Max. CW*</li> <li>Apply an RF signal to the antenna connector.</li> <li>Level: -107 dBm (1 <math>\mu</math>V)</li> <li>Mod.: OFF</li> </ul>			Max. audio output	MIXER B	L406
	4	<ul style="list-style-type: none"> <li>Operating frequency ("B" section): 0.10000 MHz</li> <li>Apply no signal to the antenna connector.</li> </ul>			Min. noise output	MIXER B	R422
	5	<ul style="list-style-type: none"> <li>Operating frequency: 14.17500 MHz</li> <li>[DUAL WATCH] switch: OFF</li> <li>Apply an RF signal to the antenna connector.</li> <li>Level: -123 dBm (0.16 <math>\mu</math>V)</li> <li>Mod.: OFF</li> <li>R265 (MAIN): Center</li> </ul>			Max. audio output	IF	L16, L17, L18, L23, L24, L25, L26, L27, L28, L31
	6	<ul style="list-style-type: none"> <li>Apply an RF signal to the antenna connector.</li> <li>Level: -93 dBm (5 <math>\mu</math>V)</li> <li>Mod.: OFF</li> </ul>			30 dB S/N ratio	MAIN	L60, L61, L64
<ul style="list-style-type: none"> <li>Apply no signal to the antenna connector.</li> </ul>					MAIN	R265	

\* CW: Clockwise



**MAIN AND IF UNITS**

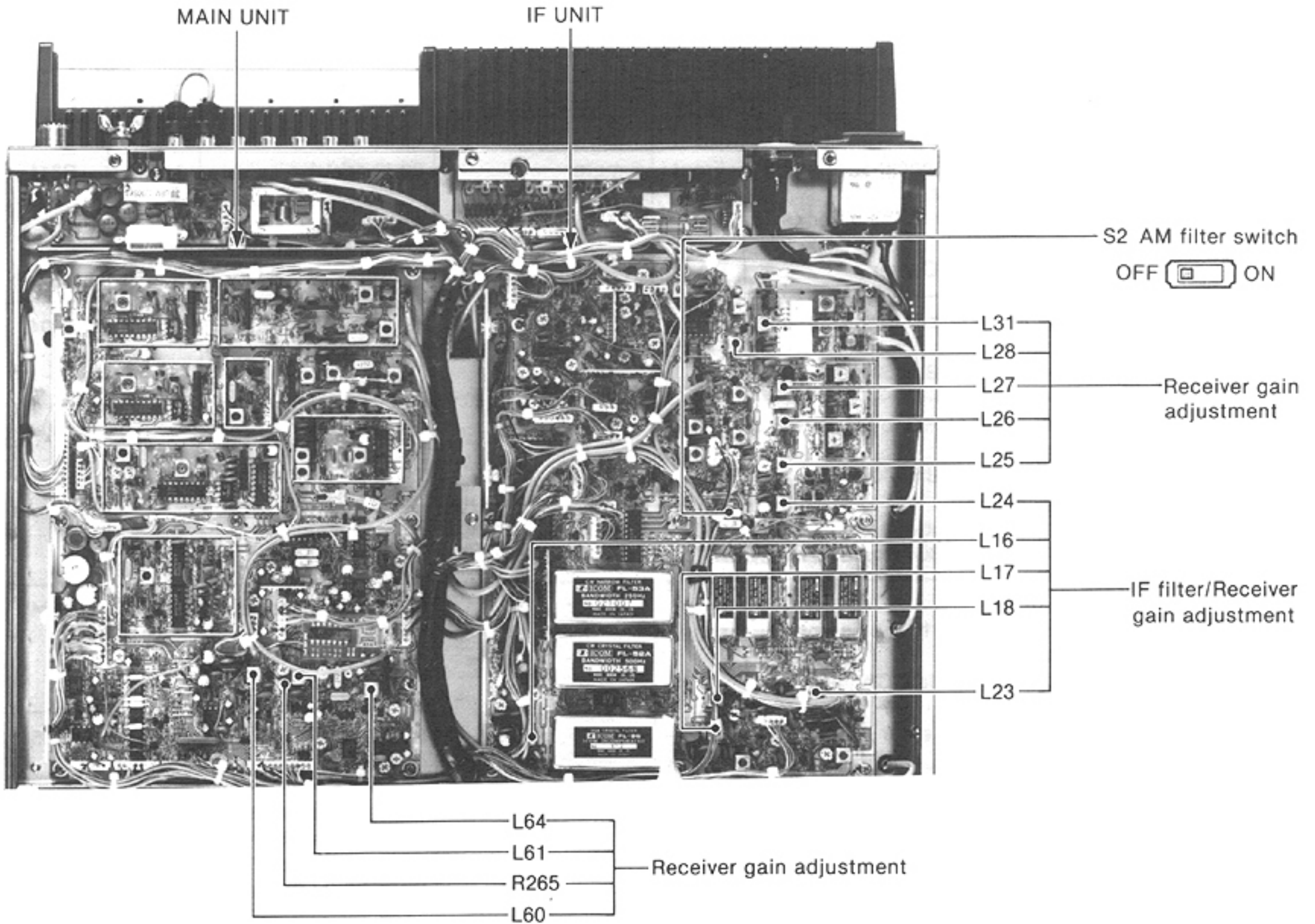

**RF, MIXER A AND B UNITS**

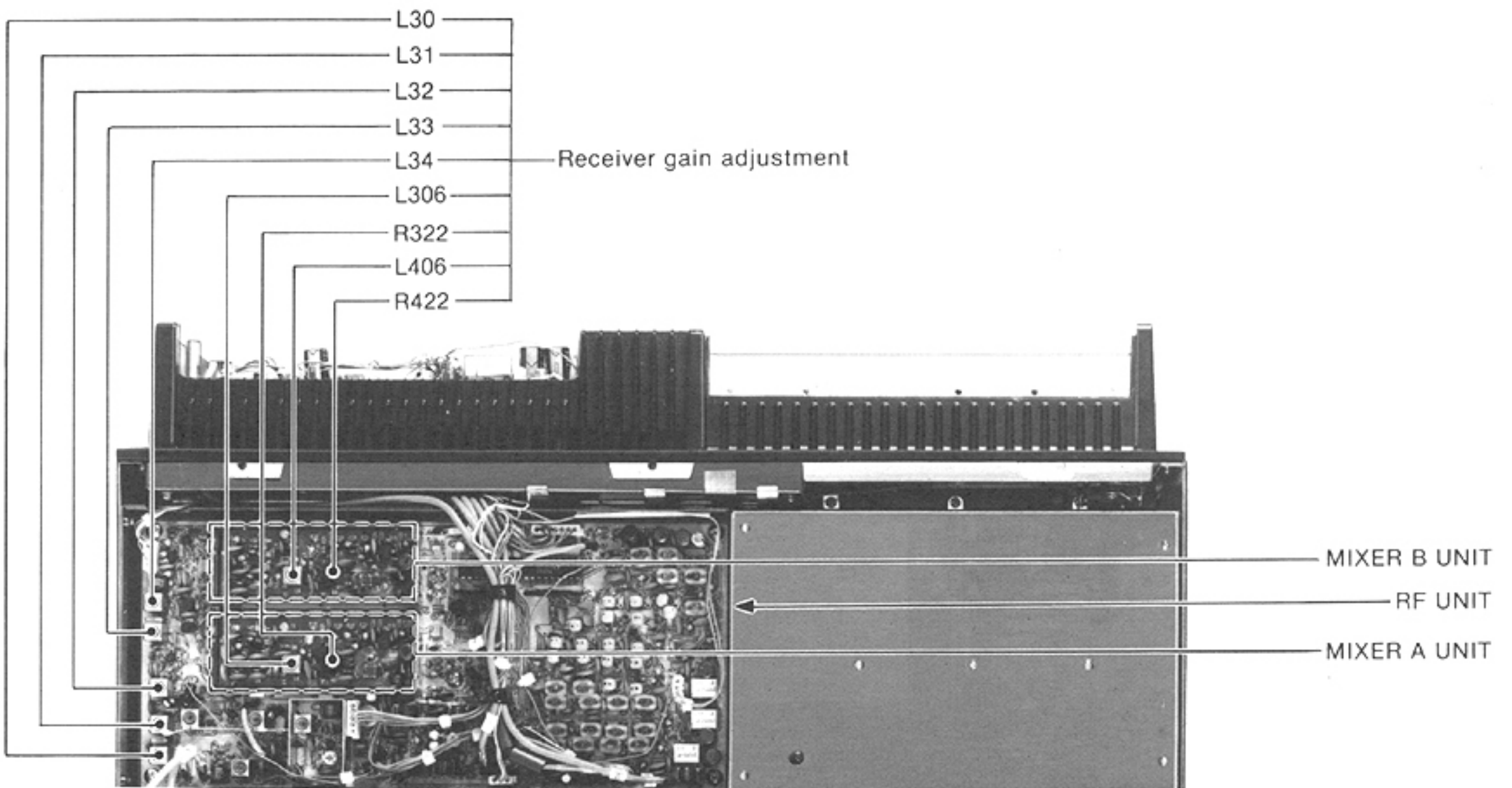

**NOTE:** For complete part numbers, "300" must be added to each binary numeral on the MIXER A UNIT and "400" must be added to each binary numeral on the MIXER B UNIT.

## RECEIVER ADJUSTMENT (CONTINUED)

ADJUSTMENT	ADJUSTMENT CONDITIONS	MEASUREMENT		VALUE	ADJUSTMENT POINT		
		UNIT	LOCATION		UNIT	ADJUST	
S-METER	1	<ul style="list-style-type: none"> <li>Operating frequency: 14.17500 MHz</li> <li>Apply no signal to the antenna connector.</li> <li>R116 (NB SW): Center</li> </ul>	Front panel	S-meter	S0 (S-scale)	MAIN	R311
	2	<ul style="list-style-type: none"> <li>Apply an RF signal to the antenna connector.</li> <li>Level: -13 dBm (50 mV)</li> </ul>			S9+60 dB (S-scale)		R304
	3	<ul style="list-style-type: none"> <li>Apply an RF signal to the antenna connector.</li> <li>Level: -73 dBm (50 <math>\mu</math>V)</li> </ul>			S9 (S-scale)		R308
	NOTE: Repeat above adjustments 2 and 3 several times. If R304 is turned max. CW,* remove R306 from the MAIN UNIT and readjust S-METER as above from step 1.						
METER SQUELCH	1	<ul style="list-style-type: none"> <li>USB mode</li> <li>Apply no signal to the antenna connector.</li> <li>[SQL] control: Max. CW*</li> </ul>	Front panel	S-meter	S9+60 dB (S-scale)	BRIGHT VR	R404
	2	<ul style="list-style-type: none"> <li>[SQL] control: Center</li> </ul>			S0 (S-scale)		R405
NOTCH FILTER	1	<ul style="list-style-type: none"> <li>Operating frequency: 14.17500 MHz</li> <li>AM mode</li> <li>Apply an RF signal to the antenna connector.</li> <li>Level: -73 dBm (50 <math>\mu</math>V)</li> <li>[NOTCH] switch: OFF</li> <li>[NOTCH] control: Max. CW* and CCW*</li> </ul>	Front panel	S-meter	S-meter remains at the same level when the notch control is turned fully CW* and CCW.*	MAIN	L64
	2	<ul style="list-style-type: none"> <li>USB mode</li> <li>[NOTCH] switch: ON</li> <li>[NOTCH] control: Center</li> <li>R276 (MAIN): Center</li> </ul>	Rear panel	Connect the AC milli-voltmeter with an 8 $\Omega$ load to the EXT. SP jack.	Min. audio output (More than 45 dB down)		Both C243 and [NOTCH] control
NOTE: If C243 is turned max. CW* or CCW* in above adjustment 2, adjust R276 and readjust C243 up to 45 dB attenuation.							

\*CW: Clockwise \*CCW: Counterclockwise

## NB SW UNIT

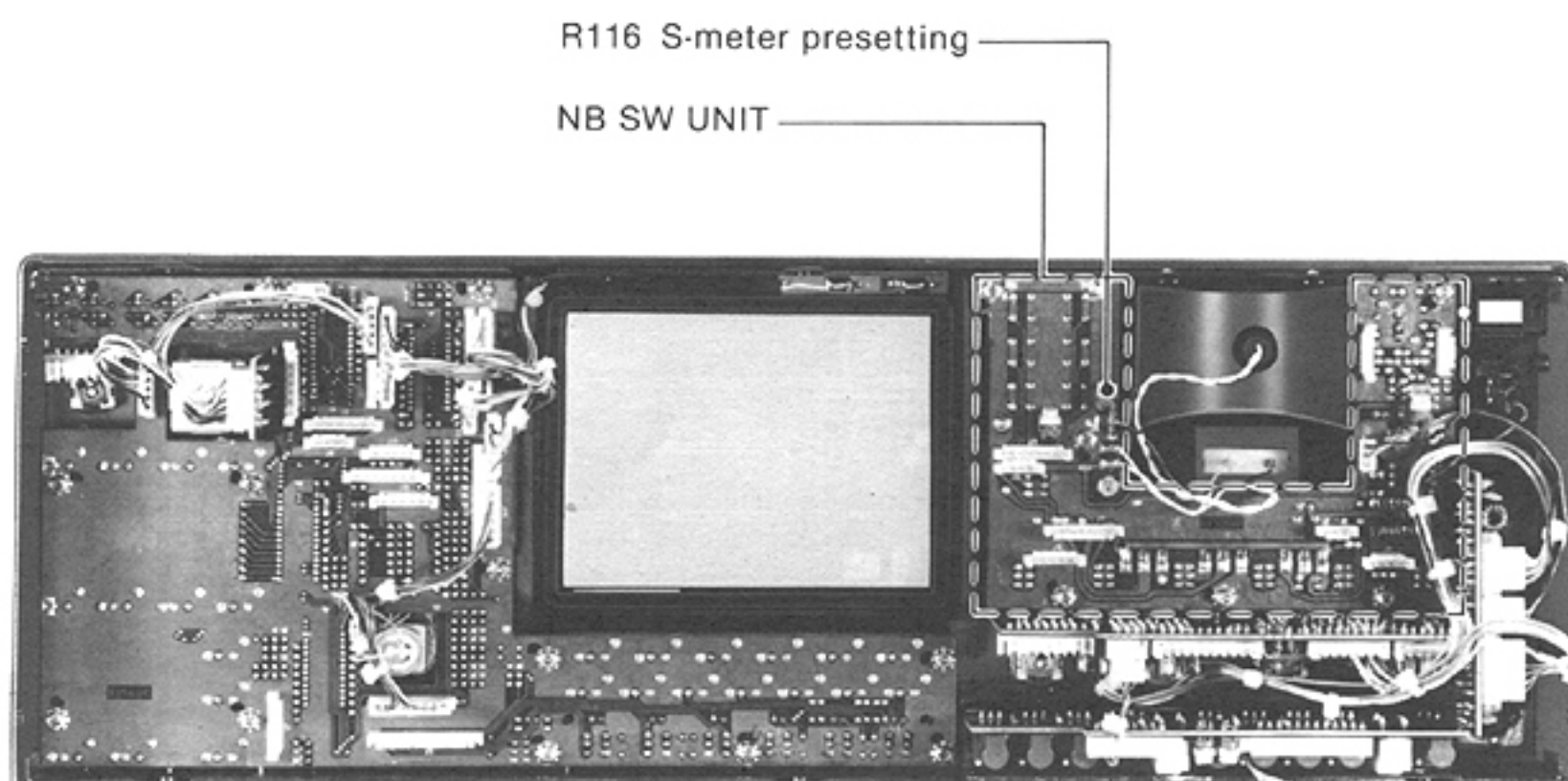

NOTE: For complete part numbers, "100" must be added to each binary numeral on the NB SW UNIT.



# MAIN AND BRIGHT VR UNITS

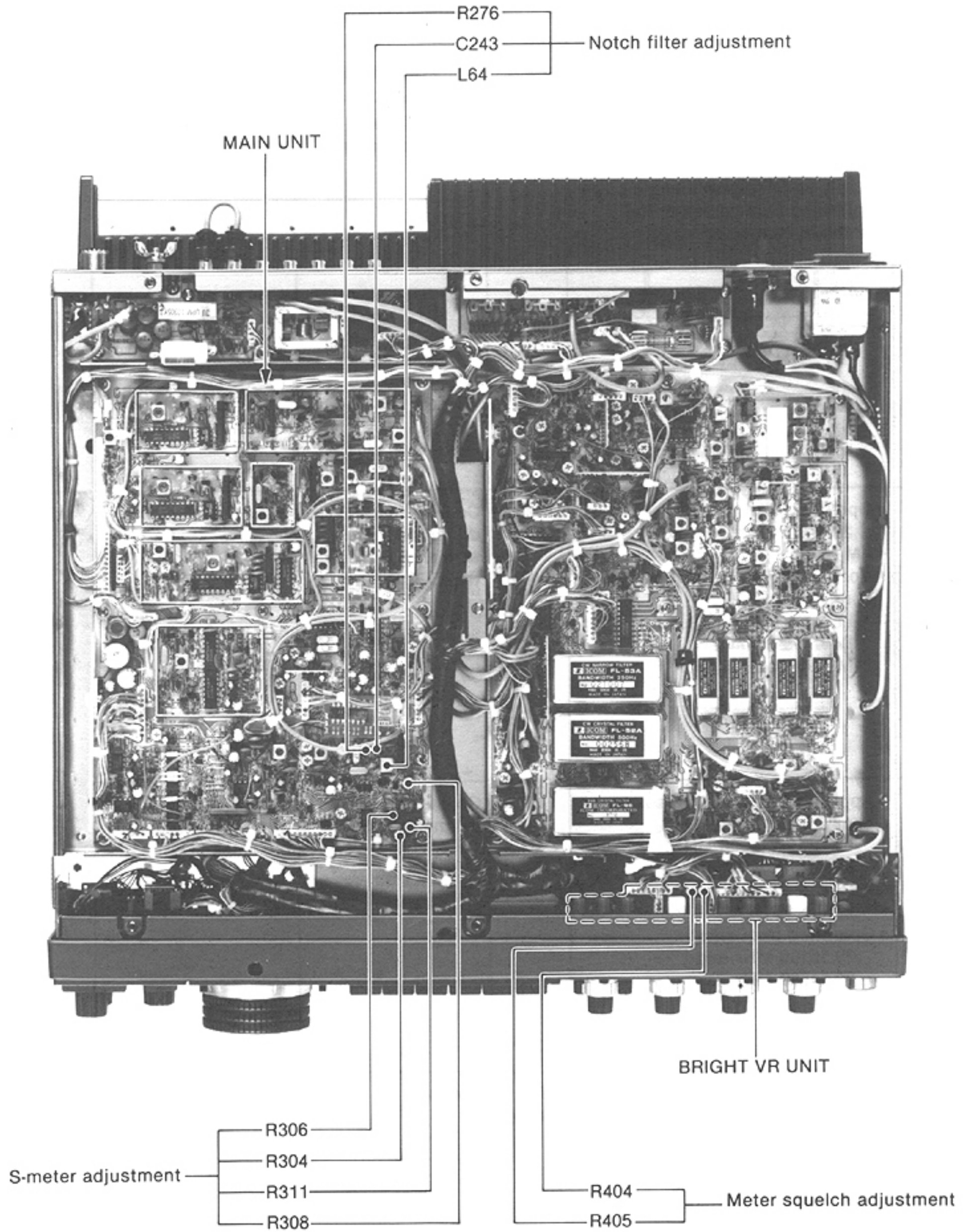

**NOTE:** For complete part numbers, "400" must be added to each binary numeral on the BRIGHT VR UNIT.

## RECEIVER ADJUSTMENT (CONTINUED)

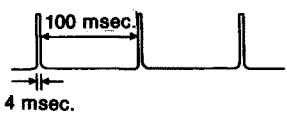
ADJUSTMENT		ADJUSTMENT CONDITIONS	MEASUREMENT		VALUE	ADJUSTMENT POINT	
			UNIT	LOCATION		UNIT	ADJUST
NOISE BLANKER	1	<ul style="list-style-type: none"> <li>Operating frequency: 14.17500 MHz</li> <li>USB mode</li> <li>Apply an RF signal including the following pulse noise to the antenna connector.</li> </ul> 	IF	Connect the oscilloscope to R283.	Adjust for maximum waveform on the oscilloscope.	IF	L33, L34, L35
FM RECEIVER	1	<ul style="list-style-type: none"> <li>Operating frequency: 29.15000 MHz</li> <li>FM mode</li> <li>Apply an RF signal to the antenna connector. Level: -97 dBm (3.2 μV) Dev. : ±3.5 kHz Mod. : 1 kHz</li> </ul>	Rear panel	Connect the distortion meter with an 8 Ω load to the EXT. SP jack.	Minimum distortion level	IF	L13, L14
	2	<ul style="list-style-type: none"> <li>Apply an RF signal to the antenna connector. Freq. : 29.15000 MHz Level: -97 dBm (3.2 μV) Dev. : ±3.5 kHz Mod. : 1 kHz</li> <li>Operating frequency: 29.15150 MHz and 29.14850 MHz</li> </ul>	IF	Connect the DC voltmeter to R71.	Adjust for a point just after output voltage becomes "LOW."		R75, R76
FM SQUELCH	1	<ul style="list-style-type: none"> <li>Operating frequency: 29.15000 MHz</li> <li>FM mode</li> <li>Apply no signal to the antenna connector.</li> <li>[SQL] control: 9 o'clock</li> </ul>	Top cover	Speaker	Squelch threshold point	MAIN	R325
BEEP TONE	1	<ul style="list-style-type: none"> <li>Push any switch which activates the beep sound.</li> </ul>	Top cover	Speaker	Verify that the level of the beep sound is adjustable.	MAIN	R186
NOTE: Set R186 to center position after above verification.							

# MAIN AND IF UNITS

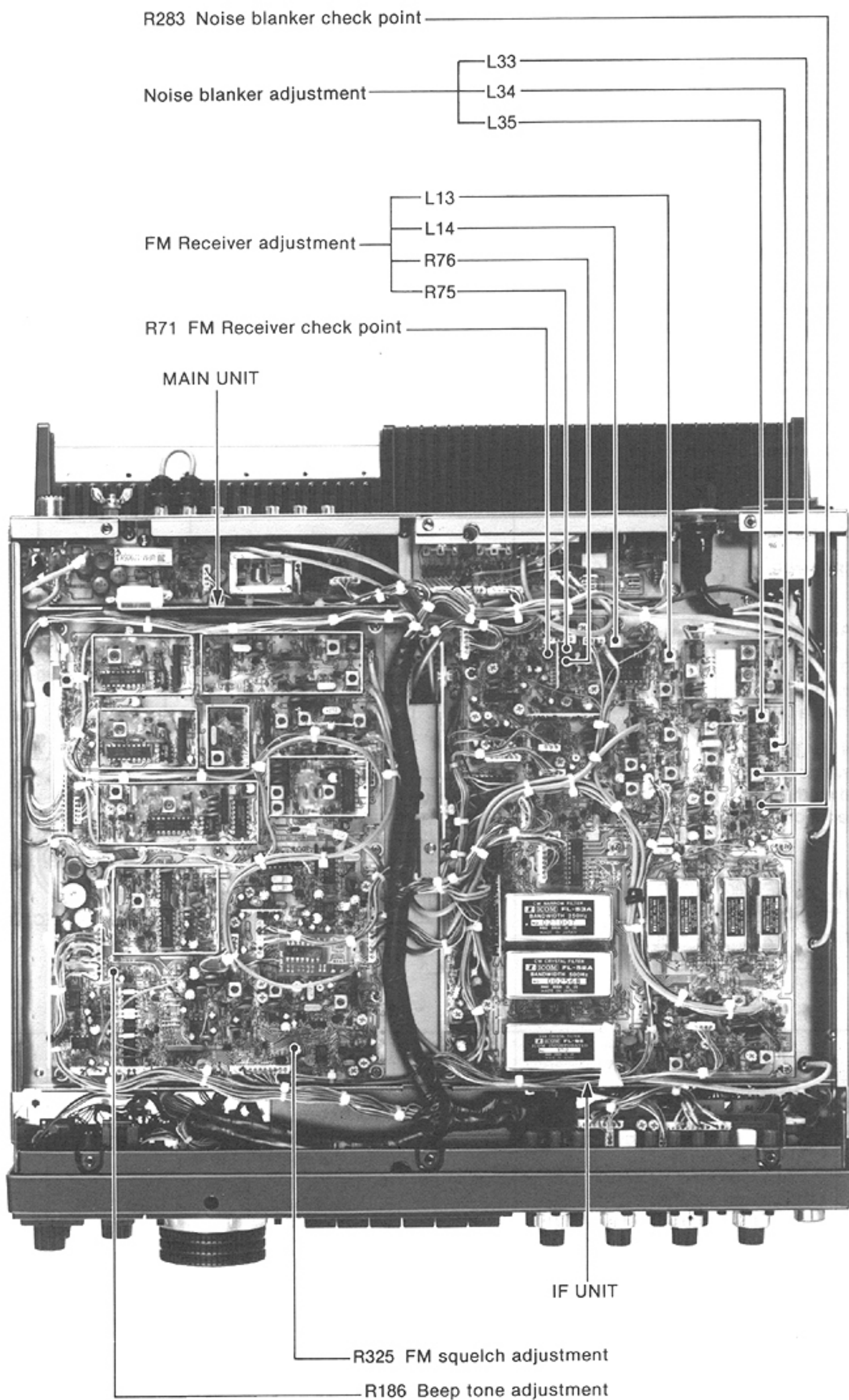

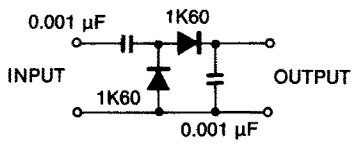
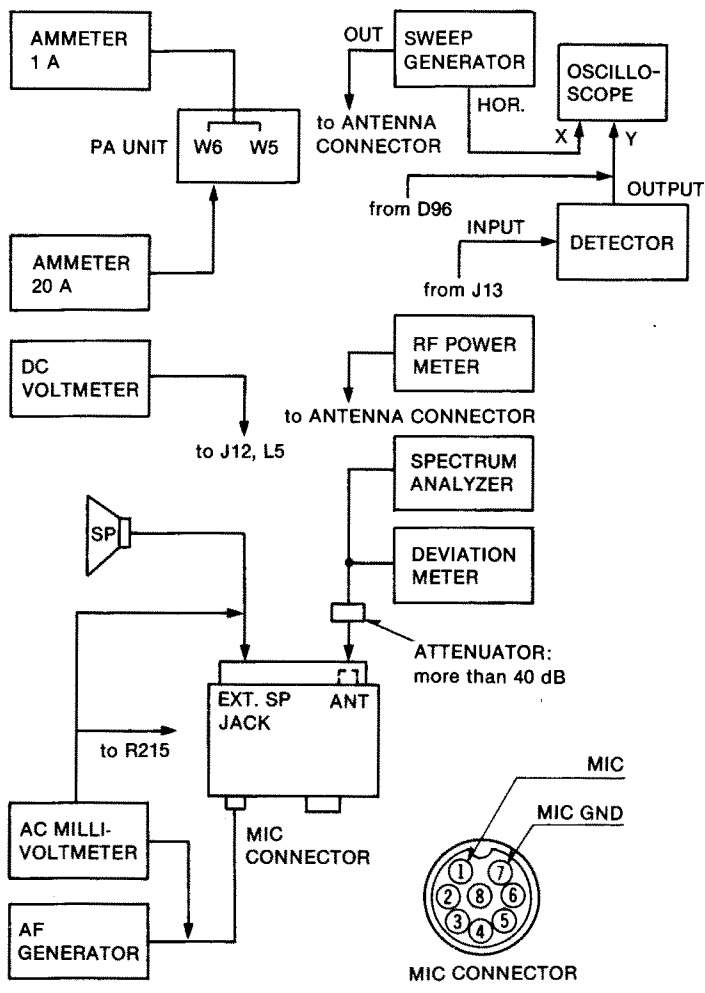

## 6-5 TRANSMITTER ADJUSTMENT

REQUIRED TEST EQUIPMENT	TEST EQUIPMENT HOOK-UP
<p>(1) RF POWER METER (TERMINATED TYPE)</p> <ul style="list-style-type: none"> <li>Measuring range : 10~200 W</li> <li>Frequency range : 1.8~30 MHz</li> <li>Impedance : 50 Ω</li> <li>SWR : Less than 1.2 : 1</li> </ul> <p>(2) AMMETER</p> <ul style="list-style-type: none"> <li>Measurement capability : 1 A and 20 A</li> </ul> <p>(3) AF GENERATOR (AG)</p> <ul style="list-style-type: none"> <li>Frequency range : 200~2000 Hz</li> <li>Output level : 0~100 mV</li> </ul> <p>(4) AC MILLI-VOLTMETER</p> <ul style="list-style-type: none"> <li>Measuring range : 2~100 mV</li> </ul> <p>(5) FM DEVIATION METER</p> <ul style="list-style-type: none"> <li>Frequency minimum : 30 MHz</li> <li>Measuring range : 0~±5 kHz</li> </ul> <p>(6) DC VOLTMETER</p> <ul style="list-style-type: none"> <li>Input impedance : 50 kΩ/DC or better</li> </ul> <p>(7) EXTERNAL SPEAKER</p> <ul style="list-style-type: none"> <li>Impedance : 8 Ω</li> </ul> <p>(8) SPECTRUM ANALYZER</p> <p>(9) OSCILLOSCOPE</p> <ul style="list-style-type: none"> <li>Frequency range : DC~50 MHz</li> <li>Measuring range : 0.01~10 V</li> </ul> <p>(10) SWEEP GENERATOR</p> <ul style="list-style-type: none"> <li>Frequency range : 0.1~100 MHz</li> <li>Sweep bandwidth : At least 10 MHz</li> <li>Output impedance : 50 Ω</li> </ul> <p>(11) DETECTOR</p> 	

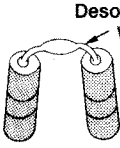
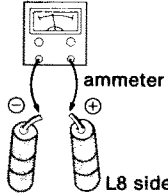
ADJUSTMENT	ADJUSTMENT CONDITIONS	MEASUREMENT		VALUE	ADJUSTMENT POINT	
		UNIT	LOCATION		UNIT	ADJUST
IDLING CURRENT (A) For driver transistors	1 <ul style="list-style-type: none"> <li>Operating frequency: 14.17500 MHz</li> <li>USB mode</li> <li>[MIC GAIN] control: Max. CCW*</li> <li>[RF PWR] control: Max. CCW*</li> <li>[DRIVE] control: Max. CCW*</li> <li>[TUNER] switch: OFF</li> <li>[COMP] switch: OFF</li> <li>Transmitting</li> </ul>	PA	Unsolder the center of W5.  Connect the ammeter to W5. 	110 mA	PA	R15

\* CCW: Counterclockwise

## TRANSMITTER ADJUSTMENT (CONTINUED)

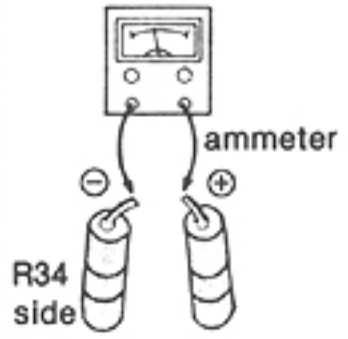
ADJUSTMENT	ADJUSTMENT CONDITIONS	MEASUREMENT		VALUE	ADJUSTMENT POINT		
		UNIT	LOCATION		UNIT	ADJUST	
⑧ For final transistors	2	• Same as step 1.	PA	Unsolder the center of W6 and connect the ammeter to W6.  	450 mA	PA	R31
NOTE: Re-solder after making adjustment.							

### PA UNIT

- R31 Idling current (final transistor) adjustment
- W5 Idling current (driver transistor) check point
- W6 Idling current (final transistor) check point
- R15 Idling current (driver transistor) adjustment

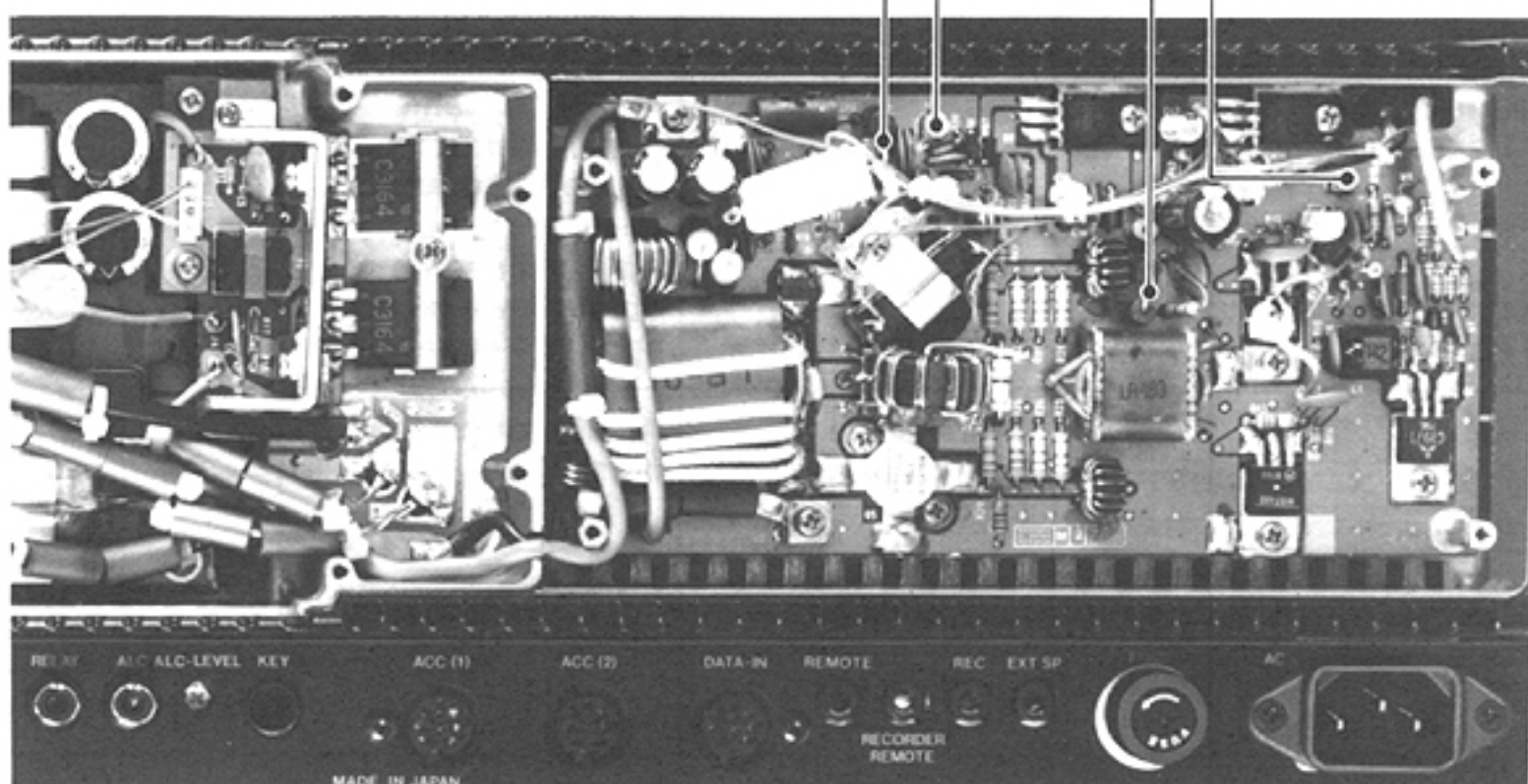

## TRANSMITTER ADJUSTMENT (CONTINUED)

ADJUSTMENT	ADJUSTMENT CONDITIONS	MEASUREMENT		VALUE	ADJUSTMENT POINT					
		UNIT	LOCATION		UNIT	ADJUST				
ALC LEVEL	1	<ul style="list-style-type: none"> <li>• USB mode</li> <li>• [MIC GAIN] control: Max. CCW*</li> <li>• [RF PWR] control: Max. CCW*</li> <li>• [ALC-LEVEL] pot: Max. CCW*</li> <li>• Transmitting</li> </ul>	IF	Connect the DC voltmeter to J12 pin 1.	3.5 V	IF	R106			
	2						<ul style="list-style-type: none"> <li>• Receiving</li> </ul>	-1.5 V ± 0.3 V	Verify	
RTTY MODULATION OUTPUT LEVEL	1	<ul style="list-style-type: none"> <li>• Operating frequency: 14.17500 MHz</li> <li>• RTTY mode</li> <li>• Transmitting</li> </ul>	MAIN	Connect the AC milli-voltmeter to R215.	15 mVrms	MAIN	R179			
FM DEVIATION	1	<ul style="list-style-type: none"> <li>• FM mode</li> <li>• [MIC GAIN] control: Center</li> <li>• [MIC TONE] control: Center</li> <li>• [DATA] switch: OFF</li> <li>• [TONE] switch: OFF</li> <li>• Set the FM deviation meter. <ul style="list-style-type: none"> <li>HPF : OFF</li> <li>LPF : 20 kHz</li> <li>Detector: (P-P)/2</li> </ul> </li> <li>• Apply an AF signal to the mic connector. <ul style="list-style-type: none"> <li>Level: 15 mV/1 kHz</li> </ul> </li> <li>• Transmitting</li> </ul>	Rear panel	Connect the FM deviation meter to the antenna connector via the attenuator.	± 4.6 kHz	MAIN	R199			
	2						<ul style="list-style-type: none"> <li>• Apply no AF signal to the mic connector.</li> <li>• [TONE] switch: ON</li> </ul>	± 0.6 kHz	R194	
	NOTE: Repeat above adjustment several times.									
SSB CARRIER POINT	1	<ul style="list-style-type: none"> <li>• USB mode</li> <li>• Apply an AF signal to the mic connector. <ul style="list-style-type: none"> <li>Level: 5 mV/300 Hz</li> </ul> </li> <li>• Transmitting</li> </ul>	Rear panel	Connect the RF power meter to the antenna connector.	75 W	Front panel	[MIC GAIN] control			
	2						<ul style="list-style-type: none"> <li>• Adjust the applied frequency to 300 Hz and 2700 Hz alternately.</li> </ul>	Adjust for same output level on both applied frequencies.	MAIN	C106
	3						<ul style="list-style-type: none"> <li>• LSB mode</li> <li>• Adjust the applied frequency to 300 Hz and 2700 Hz alternately.</li> </ul>	Adjust for same output level on both applied frequencies.		C107
IF AMP GAIN	1	<ul style="list-style-type: none"> <li>• RTTY mode</li> <li>• Transmitting</li> </ul>	IF	Connect the oscilloscope to D96 cathode.	Adjust for maximum output.	IF	L21, L23, L51, L11			
	2						<ul style="list-style-type: none"> <li>• FM mode</li> </ul>	Adjust for maximum output.		L7
							MAIN	L31, L35		
OUTPUT POWER	1	<ul style="list-style-type: none"> <li>• RTTY mode</li> <li>• [RF PWR] control: Max. CW*</li> <li>• [DRIVE] control: Max. CW*</li> <li>• S5 150/50 W selector switch: 150 W</li> <li>• Transmitting</li> </ul>	Rear panel	Connect the RF power meter to the antenna connector.	150 W	IF	R49			
	2						<ul style="list-style-type: none"> <li>• S5 150/50 W selector switch: 50 W</li> </ul>	50 W	R27	
	3						<ul style="list-style-type: none"> <li>• S5 150/50 W selector switch: 150 W</li> <li>• AM mode</li> <li>• Apply no AF signal to the mic connector.</li> </ul>	75 W	R43	

\* CW: Clockwise \* CCW: Counterclockwise

# MAIN AND IF UNITS

S5 150/50 W selector switch  
 50 W  150 W

R106 ALC level adjustment

L31 — IF amp gain adjustment  
 L35 — IF amp gain adjustment  
 C107 — SSB carrier point adjustment  
 C106 — SSB carrier point adjustment

R27 — Output power adjustment  
 R49 — Output power adjustment  
 R43 — Output power adjustment

MAIN UNIT

IF UNIT

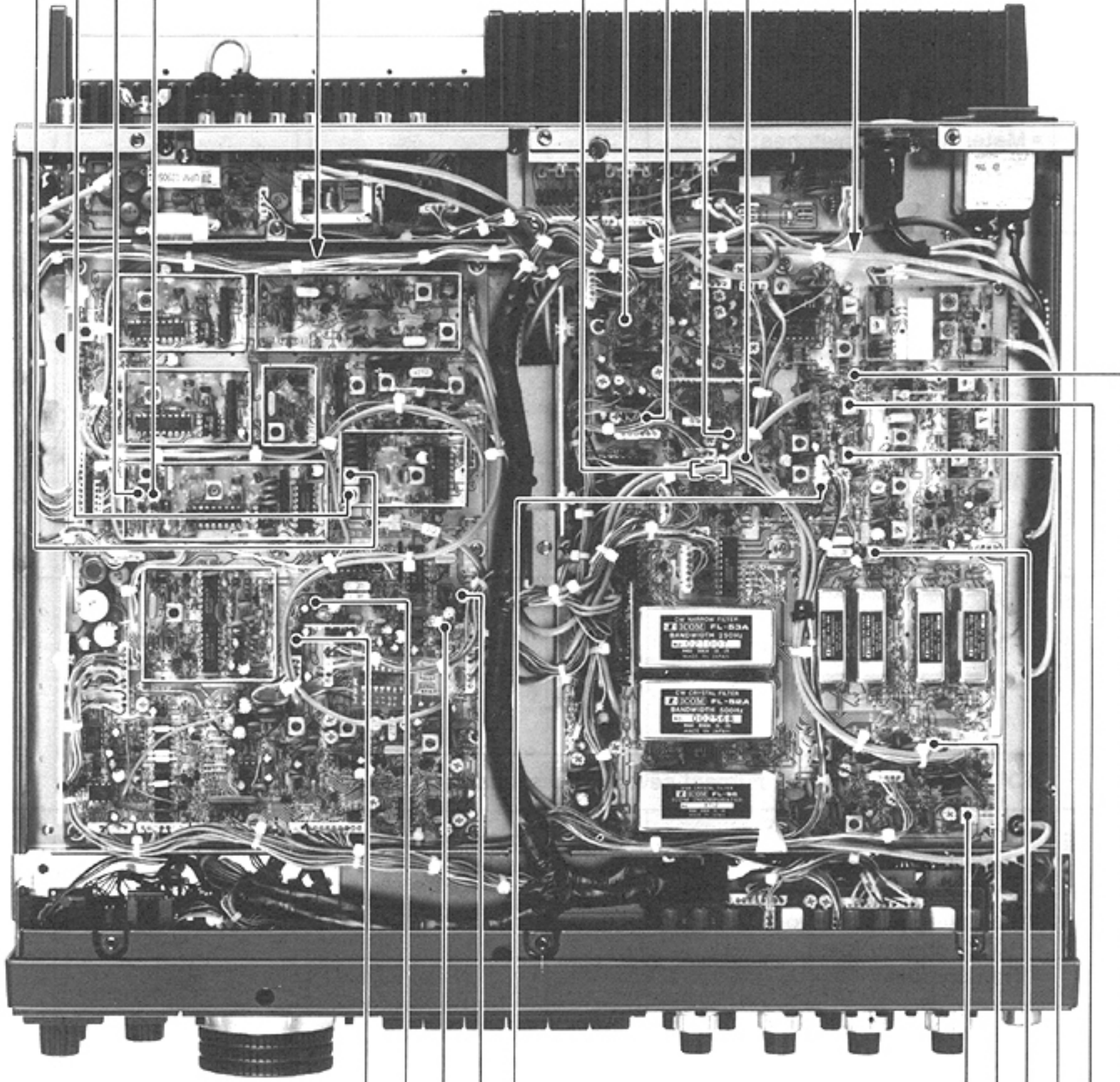

FM deviation adjustment — R194  
 R199

R215 RTTY modulation output level check point

R179 RTTY modulation output level adjustment

Pin 1 (J12) ALC level check point

IF amp gain adjustment

L21  
 L23  
 L51  
 L11  
 L7

D96 IF amp gain check point

## TRANSMITTER ADJUSTMENT (CONTINUED)

ADJUSTMENT	ADJUSTMENT CONDITIONS	MEASUREMENT		VALUE	ADJUSTMENT POINT		
		UNIT	LOCATION		UNIT	ADJUST	
Po METER	<ul style="list-style-type: none"> <li>• Operating frequency: 14.17500 MHz</li> <li>• RTTY mode</li> <li>• Meter function switches: Po</li> <li>• [DRIVE] control: Max. CW*</li> <li>• Transmitting</li> </ul>	Rear panel	Connect the RF power meter to the antenna connector.	150 W	Front panel	[RF PWR] control	
		Front panel	Multi-function meter	150 W (Po scale)	IF	R26	
Ic METER	<ul style="list-style-type: none"> <li>• USB mode</li> <li>• [MIC GAIN] control: Max. CCW*</li> <li>• Meter function switches: Ic</li> <li>• Transmitting</li> </ul>	Front panel	Multi-function meter	1 A (Ic scale)	IF	R28	
		PA	Unsolder the center of W6 and connect the ammeter to W6.	10 A	Front panel	[RF PWR] control	
	3	<ul style="list-style-type: none"> <li>• RTTY mode</li> <li>• Transmitting</li> </ul>	Front panel	Multi-function meter	10 A (Ic scale)	IF	R37
NOTE: Repeat above adjustment several times, and re-solder after making adjustment.							
SWR METER	<ul style="list-style-type: none"> <li>• RTTY mode</li> <li>• Meter function switches: SWR</li> <li>• Connect an SWR2 dummy load to the antenna connector. (100 Ω dummy load)</li> <li>• Transmitting</li> </ul>	Front panel	Multi-function meter	SWR2 (SWR scale)	IF	R73	
COMP METER	<ul style="list-style-type: none"> <li>• USB mode</li> <li>• [COMP] switch: ON</li> <li>• Meter function switches: COMP</li> <li>• Apply an AF signal to the mic connector. Level: 5 mV/1 kHz</li> <li>• Transmitting</li> </ul>	Front panel	Multi-function meter	10 dB (COMP scale)	Front panel	[MIC GAIN] control	
				Maximum (COMP scale)	IF	L20	
				0 dB (COMP scale)	Front panel	[MIC GAIN] control	
	4	<ul style="list-style-type: none"> <li>• Apply an AF signal to the mic connector. Level: 50 mV/1 kHz (20 dB up)</li> </ul>			20 dB (COMP scale)	IF	R206

\*CW: Clockwise \*CCW: Counterclockwise



# IF UNIT

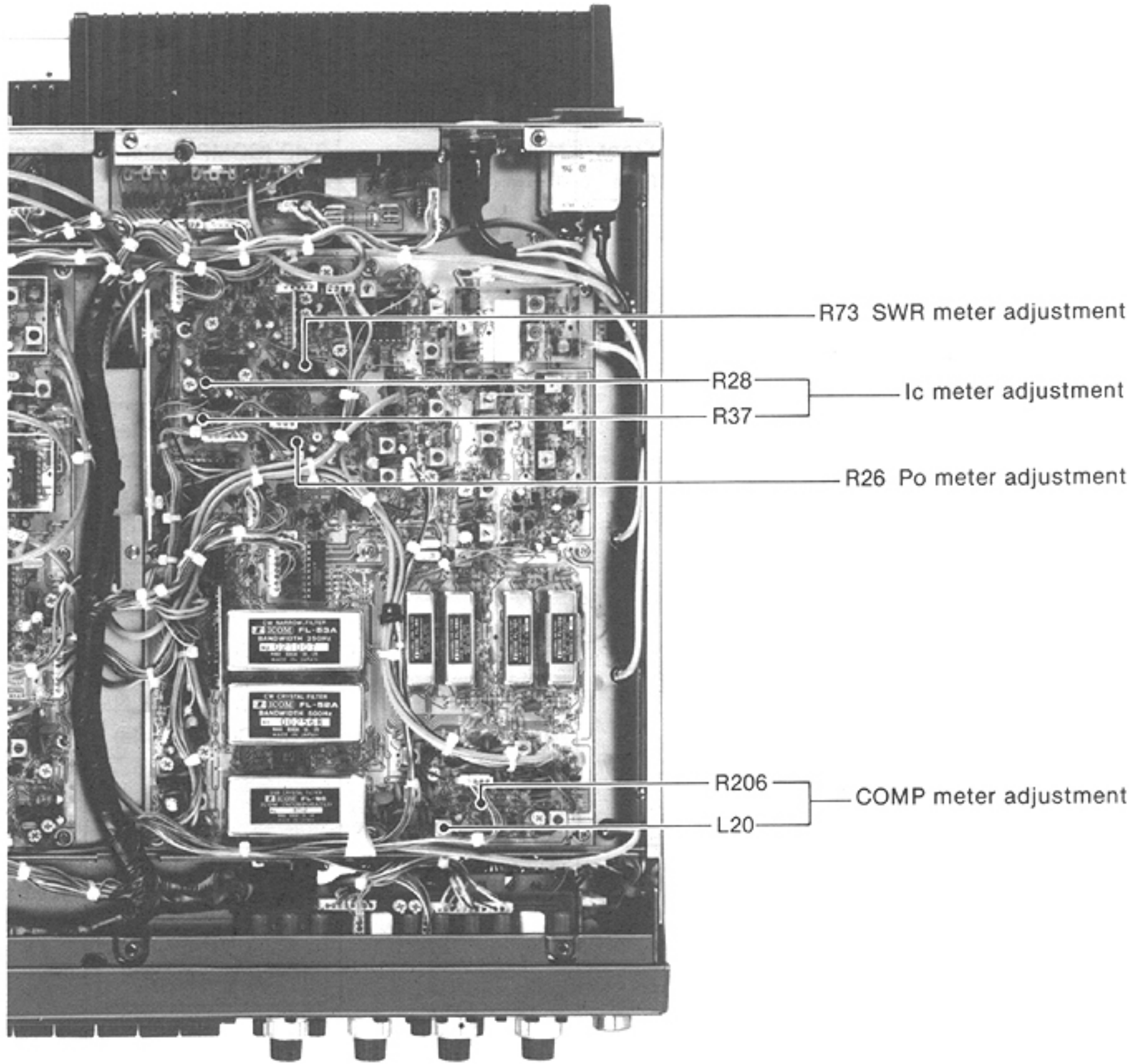

# PA UNIT

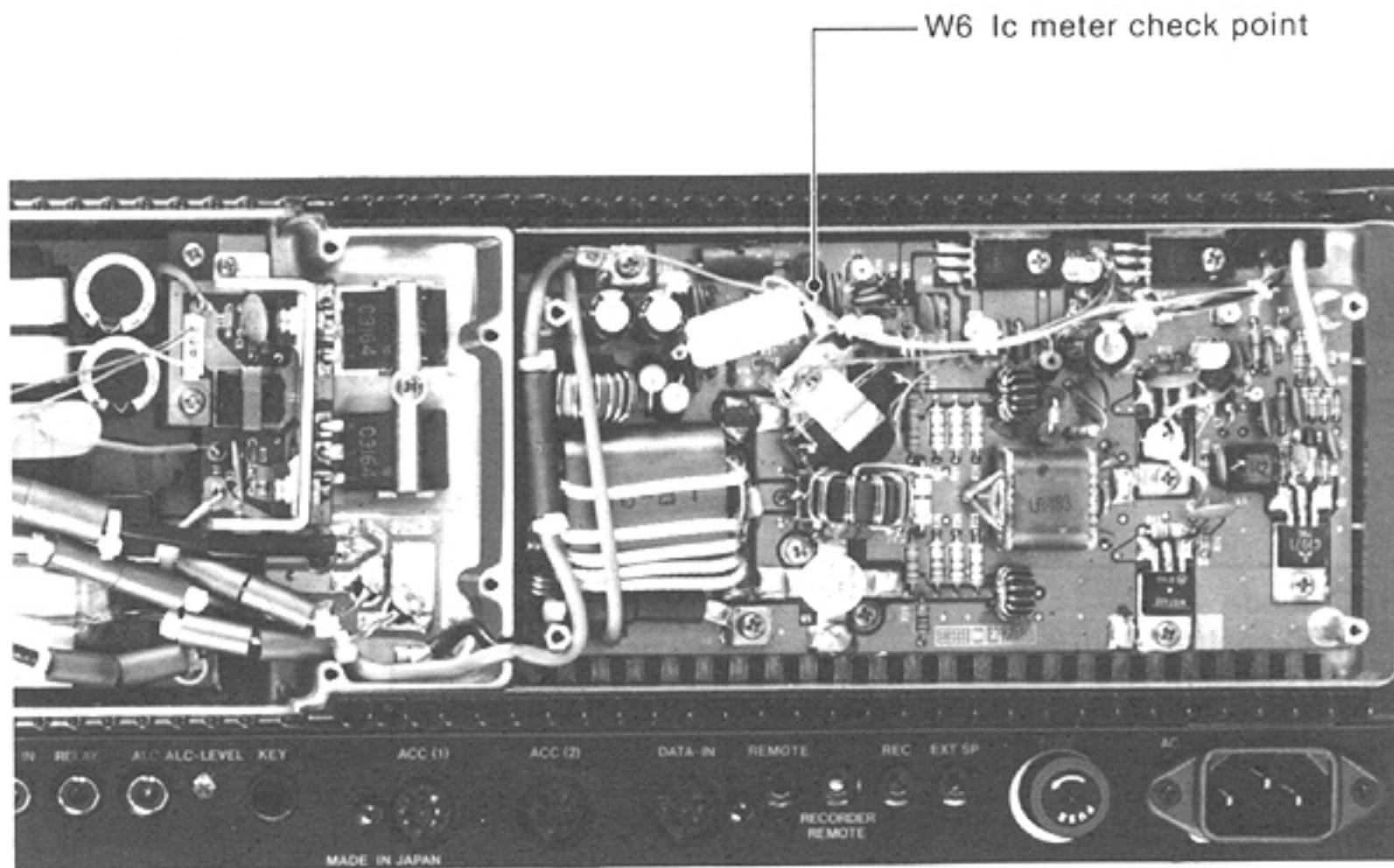

## TRANSMITTER ADJUSTMENT (CONTINUED)

ADJUSTMENT	ADJUSTMENT CONDITIONS	MEASUREMENT		VALUE	ADJUSTMENT POINT				
		UNIT	LOCATION		UNIT	ADJUST			
ALC METER	1	<ul style="list-style-type: none"> <li>Operating frequency: 14.17500 MHz</li> <li>USB mode</li> <li>[COMP] switch: OFF</li> <li>Meter function switches: ALC</li> <li>Apply an AF signal to the mic connector. Level: 5 mV/1 kHz</li> <li>Transmitting</li> </ul>	Front panel	Multi-function meter	0 dB (COMP scale)	Front panel	[MIC GAIN] control		
	2	<ul style="list-style-type: none"> <li>Apply an AF signal to the mic connector. Level: 50 mV/1 kHz (20 dB up)</li> </ul>			20 dB (COMP scale)			IF	R66
	3	<ul style="list-style-type: none"> <li>FM mode</li> <li>Apply an AF signal to the mic connector. Level: 5 mV/1 kHz</li> </ul>			0 dB (COMP scale)			Front panel	[MIC GAIN] control
	4	<ul style="list-style-type: none"> <li>Apply an AF signal to the mic connector. Level: 50 mV/1 kHz (20 dB up)</li> </ul>			20 dB (COMP scale)			IF	R319
APC SET	1	<ul style="list-style-type: none"> <li>RTTY mode</li> <li>Meter function switches: Po</li> <li>Remove any connection from the antenna connector.</li> </ul>	Front panel	Multi-function meter	15 W (Po scale)	IF	R57		
	2	<ul style="list-style-type: none"> <li>Meter function switches: Ic</li> <li>[DRIVE] control: Max. CCW*</li> <li>Ground L4 to chassis.</li> <li>R36 (IF UNIT): Max. CCW*</li> <li>Connect a 50 Ω dummy load to the antenna connector.</li> </ul>			15 A (Ic scale)			Front panel	[DRIVE] control
	3				14 A (Ic scale)			IF	R36
NOTE: After above adjustment, remove the jumper wire from L4.									
TRANSMIT GAIN	1	<ul style="list-style-type: none"> <li>Operating frequency: 14.17500 MHz</li> <li>USB mode</li> </ul>	MAIN	Connect the AC milli-voltmeter to R215.	15 mV	Front panel	[MIC GAIN] control		
	2	<ul style="list-style-type: none"> <li>Meter function switches: ALC</li> <li>Apply an AF signal to the mic connector. Level: 5 mV/1 kHz</li> <li>Transmitting</li> </ul>	Front panel	Multi-function meter	100 % (ALC scale)			IF	R122
	3	<ul style="list-style-type: none"> <li>RTTY mode</li> <li>[DRIVE] control: Center</li> <li>[COMP] switch: OFF</li> </ul>			100 % (ALC scale)				
	4	<ul style="list-style-type: none"> <li>Operating frequency: 29.50000 MHz</li> <li>Transmitting</li> </ul>			More than S5 (S-scale)				Verify
NOTE: If the meter movement drops under S5 in above verification 4, readjust R334 up to S5 position.									

\*CCW: Counterclockwise

# MAIN AND IF UNITS

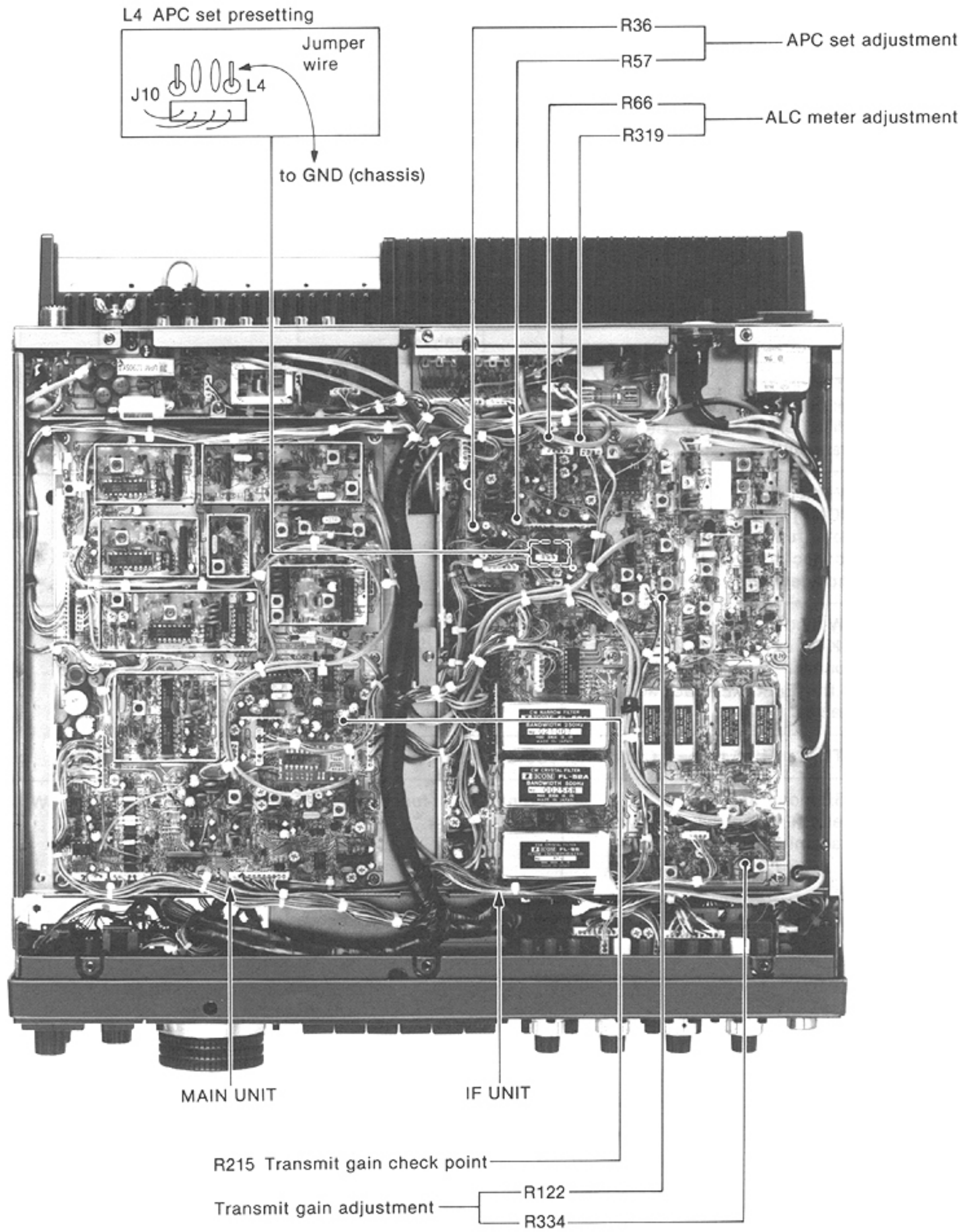

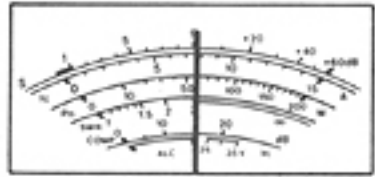
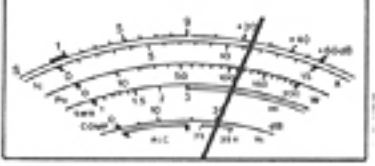

## TRANSMITTER ADJUSTMENT (CONTINUED)

ADJUSTMENT	ADJUSTMENT CONDITIONS	MEASUREMENT		VALUE	ADJUSTMENT POINT	
		UNIT	LOCATION		UNIT	ADJUST
CARRIER SUPPRESSION	1 <ul style="list-style-type: none"> <li>• Operating frequency: 14.17500 MHz</li> <li>• USB mode</li> <li>• [MIC GAIN] control: Max. CCW*</li> <li>• Transmitting</li> </ul>	Rear panel	Connect the spectrum analyzer to the antenna connector via the attenuator.  The spectrum scope screen can be used instead of the spectrum analyzer.	Minimum carrier level (Less than -40 dB)	IF	R142, R145 (Alternately adjust)
MONITOR	1 <ul style="list-style-type: none"> <li>• RTTY mode</li> <li>• [MONITOR] switch: ON</li> <li>• [MONI GAIN] control: Center</li> <li>• Transmitting</li> </ul>	Rear panel	Connect the AC milli-voltmeter with an 8 Ω load to the EXT. SP jack.	Max. audio output	IF	L8, L9
CW DRIVE LEVEL	1 <ul style="list-style-type: none"> <li>• CW mode</li> <li>• [COMP] switch: ON</li> <li>• Meter function switches: COMP</li> <li>• Connect a key to the [KEY] jack and keep the key down.</li> </ul>	Front panel	Multi-function meter	15 dB (COMP scale) 	IF	R144
ELECTRONIC KEYS WEIGHT	1 <ul style="list-style-type: none"> <li>• CW mode</li> <li>• [BK-IN] switch: ON</li> <li>• Connect an iambic keyer paddle to the [ELEC-KEY] jack and close the key.</li> </ul>	Top cover	Speaker	Verify that the space width is adjustable.	NB SW	R105
NOTE: Set R115 to max. CCW* after above verification.						
Vc METER	1 <ul style="list-style-type: none"> <li>• USB mode</li> <li>• Meter function switches: Vc</li> <li>• Transmitting</li> </ul>	Front panel	Multi-function meter	30 V (Vc scale) 	NB SW	R115

\* CCW: Counterclockwise

### NB SW UNIT

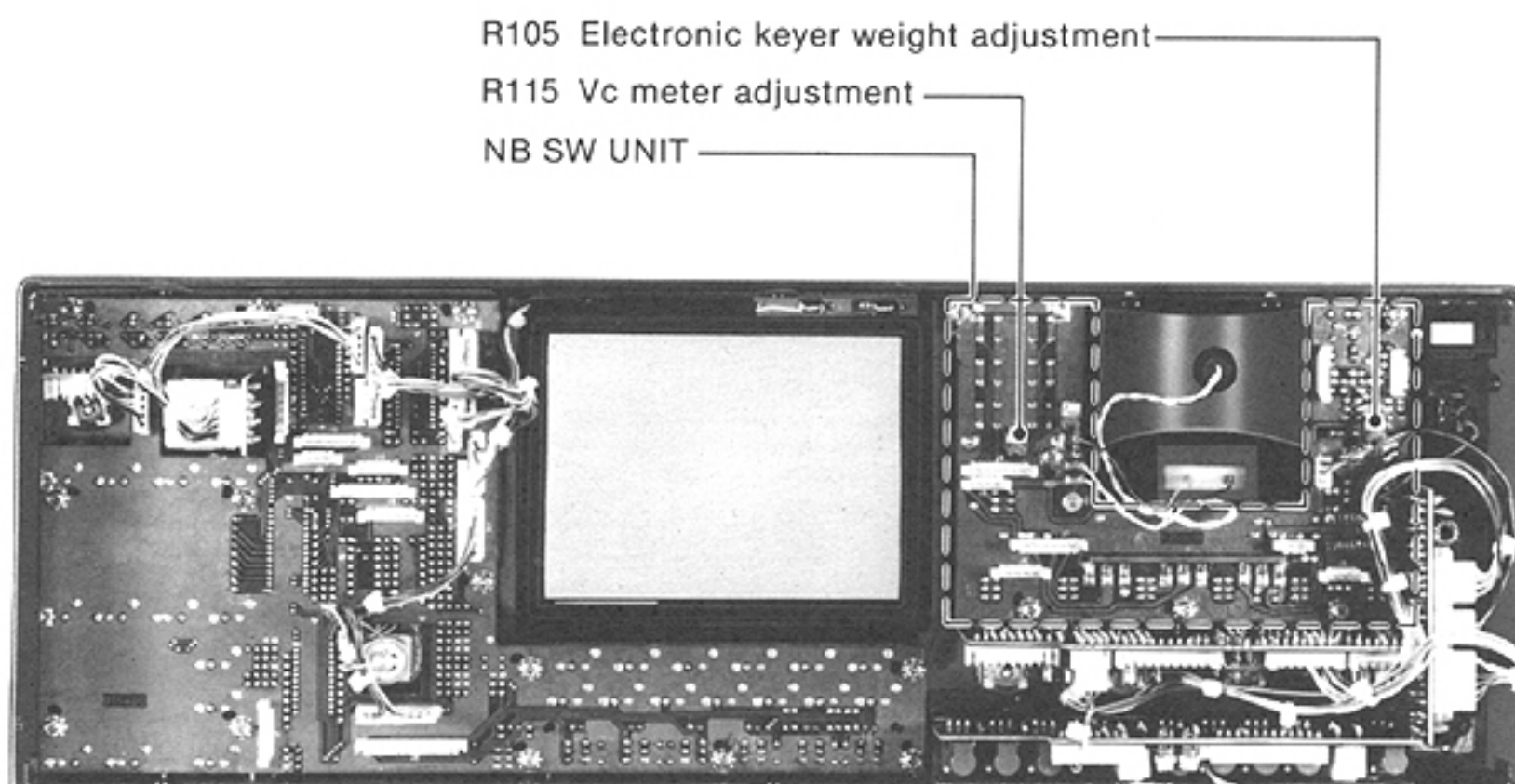

NOTE: For complete part numbers, "100" must be added to each binary numeral on the NB SW UNIT.

# IF UNIT

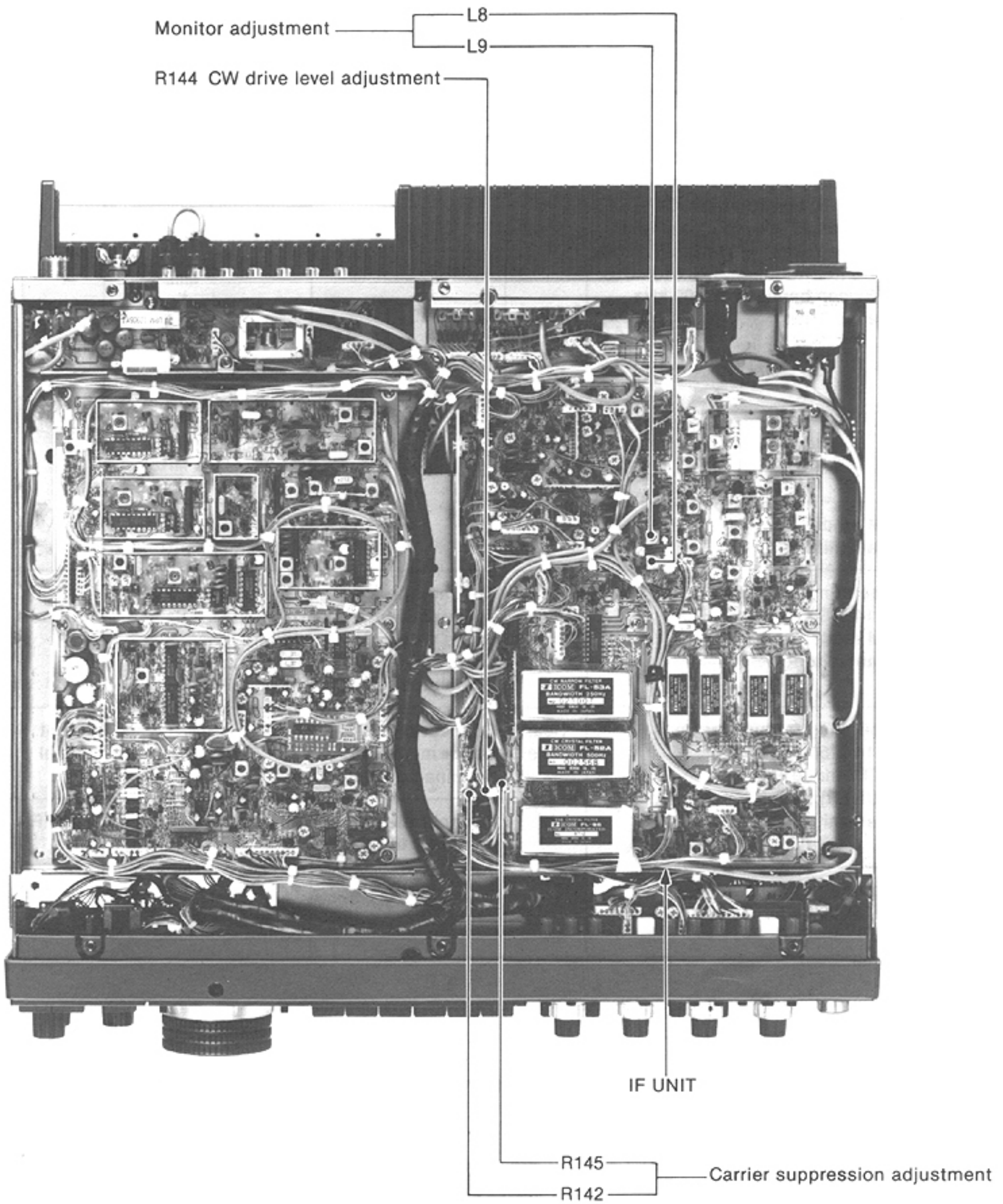

## TRANSMITTER ADJUSTMENT (CONTINUED)

ADJUSTMENT	ADJUSTMENT CONDITIONS	MEASUREMENT		VALUE	ADJUSTMENT POINT				
		UNIT	LOCATION		UNIT	ADJUST			
TX RF FILTER	1	<ul style="list-style-type: none"> <li>Operating frequency: 14.10000 MHz</li> <li>USB mode</li> <li>[DRIVE] control: Max. CW*</li> <li>[RF PWR] control: Max. CW*</li> </ul>	RF	Connect the oscilloscope to J13 via the detector.	Adjust for maximum output.	RF	L30, L31, L126, L127, L128		
	2						<ul style="list-style-type: none"> <li>Apply an RF sweep signal to J6.</li> <li>Sweep level: -30 dBm (7.1 mV)</li> <li>Center frequency: 46.510 MHz</li> <li>Sweep bandwidth: 100 kHz</li> <li>Transmitting</li> </ul>	Adjust as follows:	L30, L31, L126
	3						<ul style="list-style-type: none"> <li>FM mode</li> <li>Transmitting</li> </ul>	Minimum vestigial AM component	L126
MIXER BALANCE	1	<ul style="list-style-type: none"> <li>Operating frequency: 14.17500 MHz</li> <li>FM mode</li> <li>Transmitting</li> </ul>	Rear panel	Connect the spectrum analyzer to the antenna connector via the attenuator.	Minimum spurious level of 24 MHz and 14 MHz band frequencies.	RF	R140		
SWR	1	<ul style="list-style-type: none"> <li>Operating frequency: 14.17500 MHz</li> <li>RTTY mode</li> <li>[TUNER] switch: OFF</li> <li>Transmitting</li> </ul>	Rear panel	Connect the RF power meter to the antenna connector.	150 W	Front panel	[RF PWR] control		
	2		IF	Connect the DC voltmeter to L5.	Minimum	FILTER	C44		
	3		<ul style="list-style-type: none"> <li>Operating frequency: 1.90000 MHz, 29.00000 MHz</li> </ul>	Readjust C44 for same output level on both frequencies.	C44				

\*CW: Clockwise

### IF UNIT

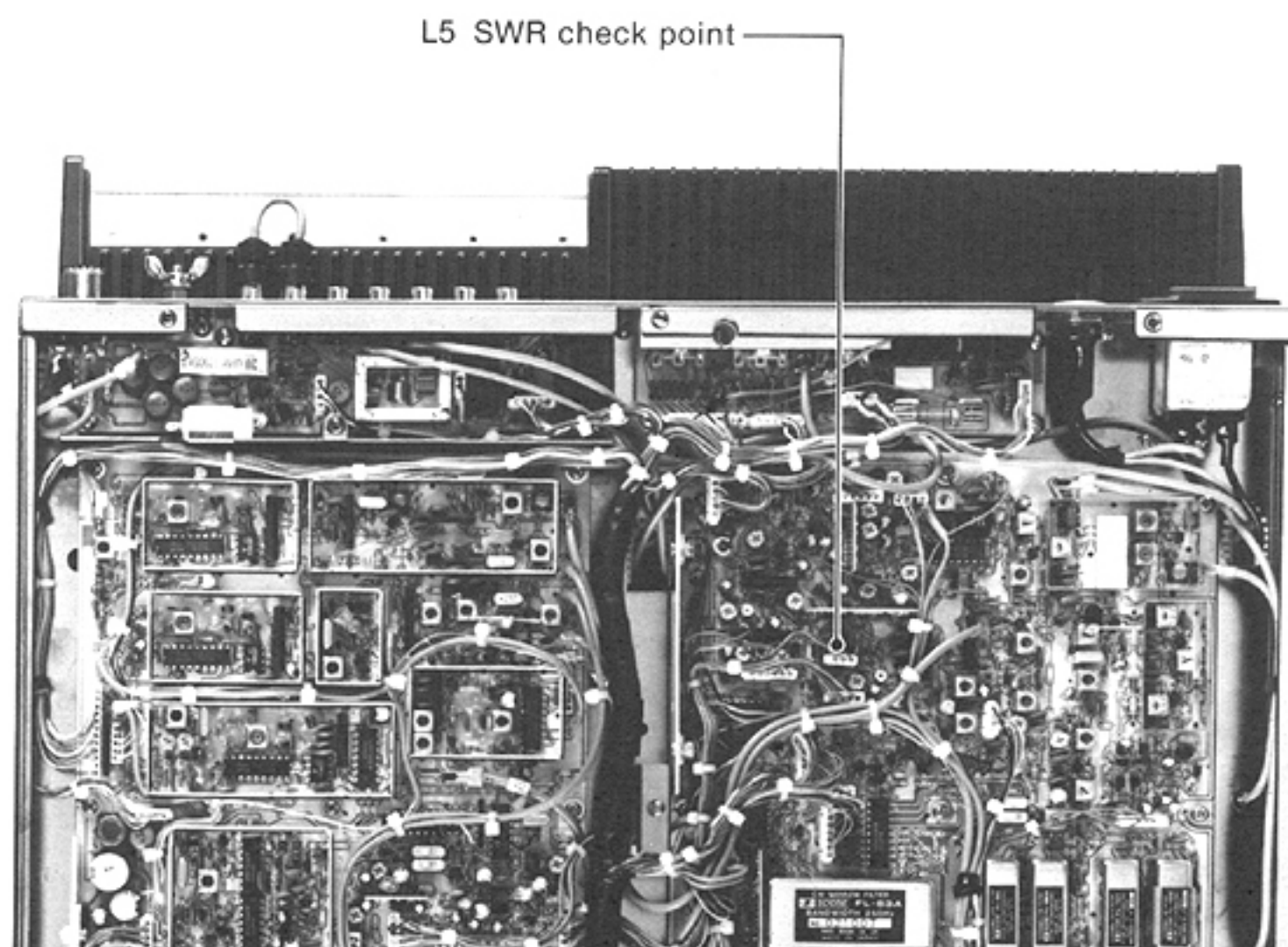



# RF AND FILTER UNITS

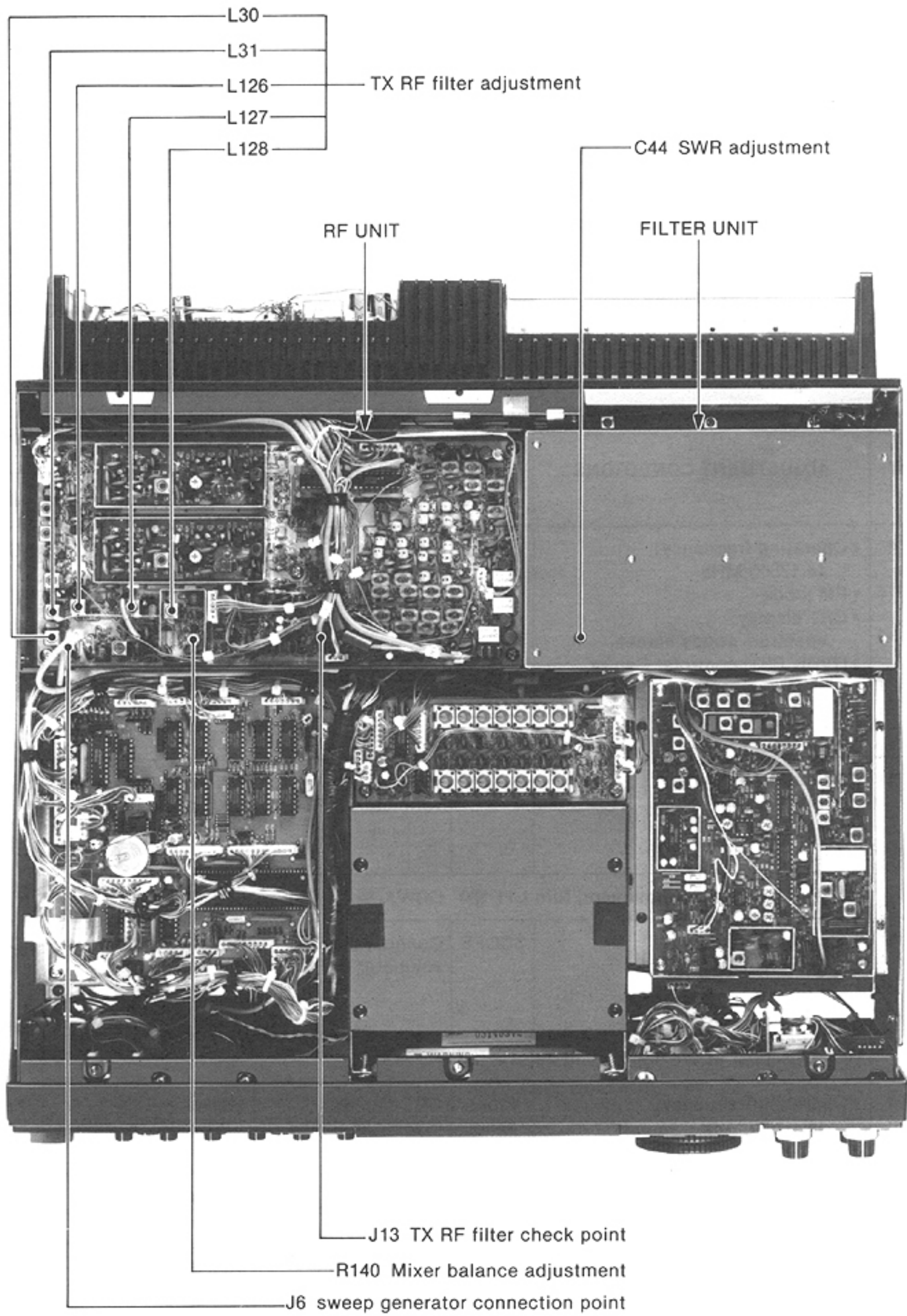

## 6-6 SPECTRUM SCOPE ADJUSTMENT



REQUIRED TEST EQUIPMENT		TEST EQUIPMENT HOOK-UP					
(1) FREQUENCY COUNTER • Frequency range : 0.1~100 MHz • Frequency accuracy : $\pm 1$ ppm or better • Sensitivity : 100 mV or better  (2) RF VOLTMETER • Frequency range : 0.1~100 MHz • Measuring range : 0.01~10 V  (3) STANDARD SIGNAL GENERATOR (SSG) • Frequency range : 0.1~50 MHz • Output level : $-127 \sim -17$ dBm (0.1 $\mu$ V~32 mV)							
ADJUSTMENT	ADJUSTMENT CONDITIONS	MEASUREMENT		VALUE	ADJUSTMENT POINT		
		UNIT	LOCATION		UNIT	ADJUST	
CENTER FREQUENCY PRE-ADJUSTMENT	1	<ul style="list-style-type: none"> <li>Operating frequency: 14.17500 MHz</li> <li>FM mode</li> <li>CRT display: spectrum scope screen</li> <li>[TWIN PBT] controls: Center</li> <li>S2 span selector switch: 0 SPAN</li> <li>Receiving</li> </ul>	SCOPE	Connect the frequency counter to R134.	810 kHz	SCOPE	L43
1ST LO OUTPUT LEVEL	1	<ul style="list-style-type: none"> <li>Operating frequency: 14.17500 MHz</li> <li>FM mode</li> </ul>	SCOPE	Connect the RF voltmeter to R14.	Adjust for maximum output.	SCOPE	L11, L10
NOTE: After above adjustment, turn L11 180° CCW.*							
2ND LO OUTPUT LEVEL	1	<ul style="list-style-type: none"> <li>Operating frequency: 14.17500 MHz</li> <li>FM mode</li> </ul>	SCOPE	Connect the RF voltmeter to R39.	Adjust for maximum output.	SCOPE	L25, L24, L23, L22
NOTE: Repeat above adjustment several times.							
RF GAIN	1	<ul style="list-style-type: none"> <li>Operating frequency: 14.10000 MHz</li> <li>S2 span selector switch: 0 SPAN</li> <li>[PREAMP] switch: OFF</li> <li>Attenuator switches: OFF</li> <li>Apply an RF signal to the antenna connector.</li> <li>Level: <math>-33</math> dBm (5 mV)</li> <li>Mod : OFF</li> <li>R48: Center</li> <li>R75: Center</li> <li>R80: Center</li> </ul>	Front panel	CRT display (Spectrum Scope screen) 	Maximum	Front panel	Main dial
	2				Maximum	RF	L35
	3				Maximum (Repeat several times.)	SCOPE	L5, L6, L7
	4				Maximum (Repeat several times.)		L16, L17, L18
	5				Maximum (Repeat several times.)		L34, L33, L31, L30, L29
NOTE: Adjust the signal generator output level each time to show the spectrum scope screen at 50 % of full scale. After completing the adjustment, return S2 to its original condition.							

\* CCW: Counterclockwise

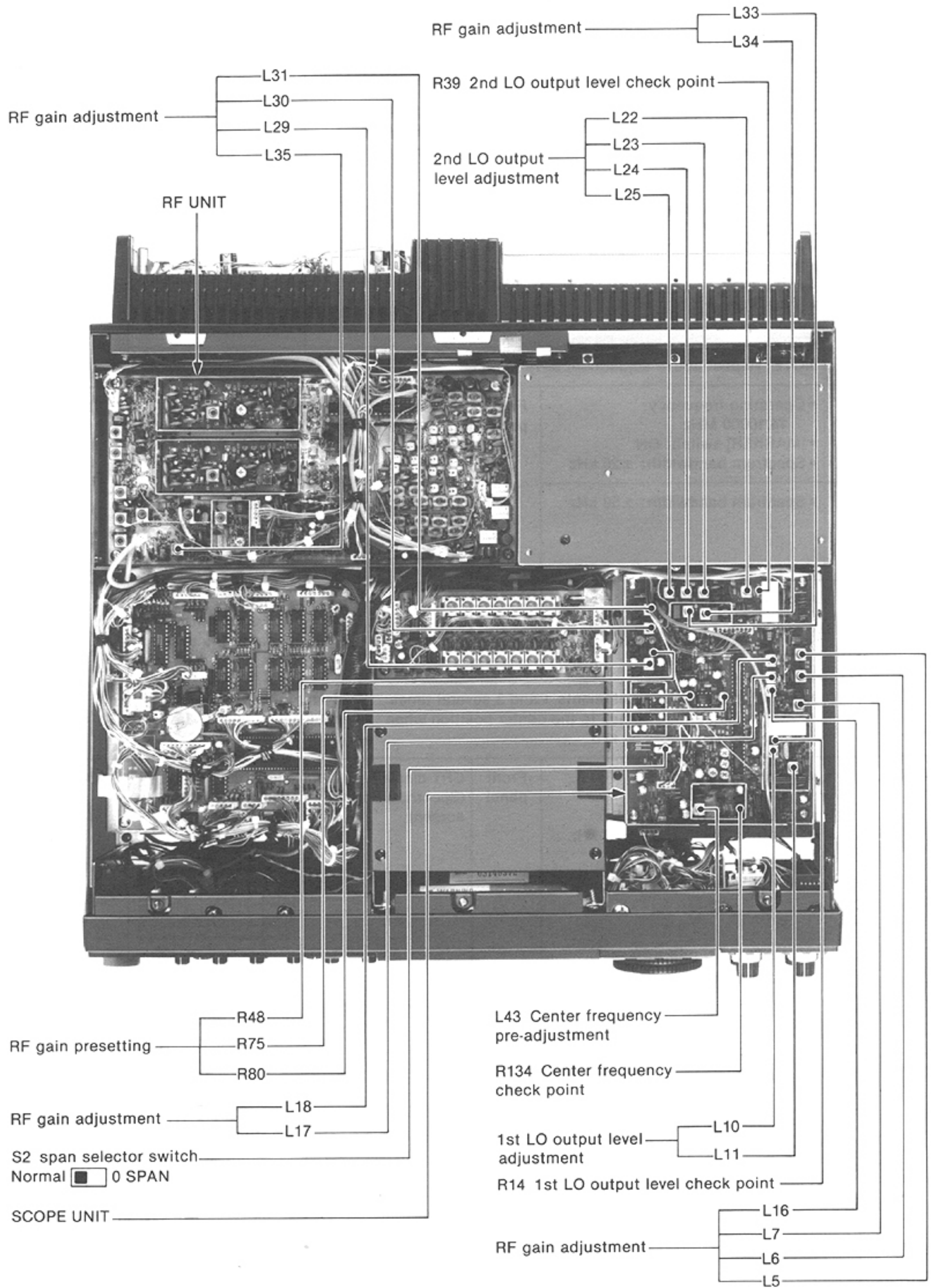
# RF AND SCOPE UNITS

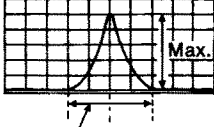
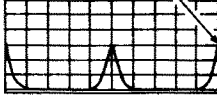
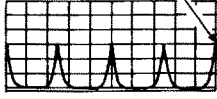

## SPECTRUM SCOPE ADJUSTMENT (CONTINUED)

ADJUSTMENT	ADJUSTMENT CONDITIONS	MEASUREMENT		VALUE	ADJUSTMENT POINT		
		UNIT	LOCATION		UNIT	ADJUST	
IF FILTER	<ul style="list-style-type: none"> <li>• Operating frequency: 14.10000 MHz</li> <li>• Spectrum bandwidth: <math>\pm 25</math> kHz</li> <li>• Apply an RF signal to the antenna connector. Level: <math>-63</math> dBm (<math>160 \mu\text{V}</math>) Mod.: OFF</li> <li>• R102: Center</li> <li>• R103: Center</li> <li>• R104: Center</li> <li>• R122: Center</li> </ul>	Front panel	CRT display (Spectrum Scope screen)	Adjust as follows:  Symmetrical waves	SCOPE	L34, L33, L31, L30, L29	
							NOTE: Repeat above adjustment several times.
CENTER FREQUENCY	1	Front panel	CRT display (Spectrum Scope screen)	Adjust the 14.100 MHz marker signal to the center position.	SCOPE	L43	
	2			Adjust the 14.100 MHz marker signal to the center position.			R122
	3			Adjust the 14.100 MHz marker signal to the center position.			R122
	NOTE: Repeat above adjustments 1 and 3 several times. Verify that the 14.100 MHz marker signal comes to the center position when the spectrum bandwidth is $\pm 25$ kHz and $\pm 50$ kHz.						
HORIZONTAL GAIN	1	Front panel	CRT display (Spectrum Scope screen)	Adjust the 14.125 MHz marker signal to the right edge. Adjustment point 	SCOPE	R102	
	2			Adjust the 14.150 MHz marker signal to the right edge. Adjustment point 			R103
	3			Adjust the 14.200 MHz marker signal to the right edge. Adjustment point 			R104



# SCOPE UNIT

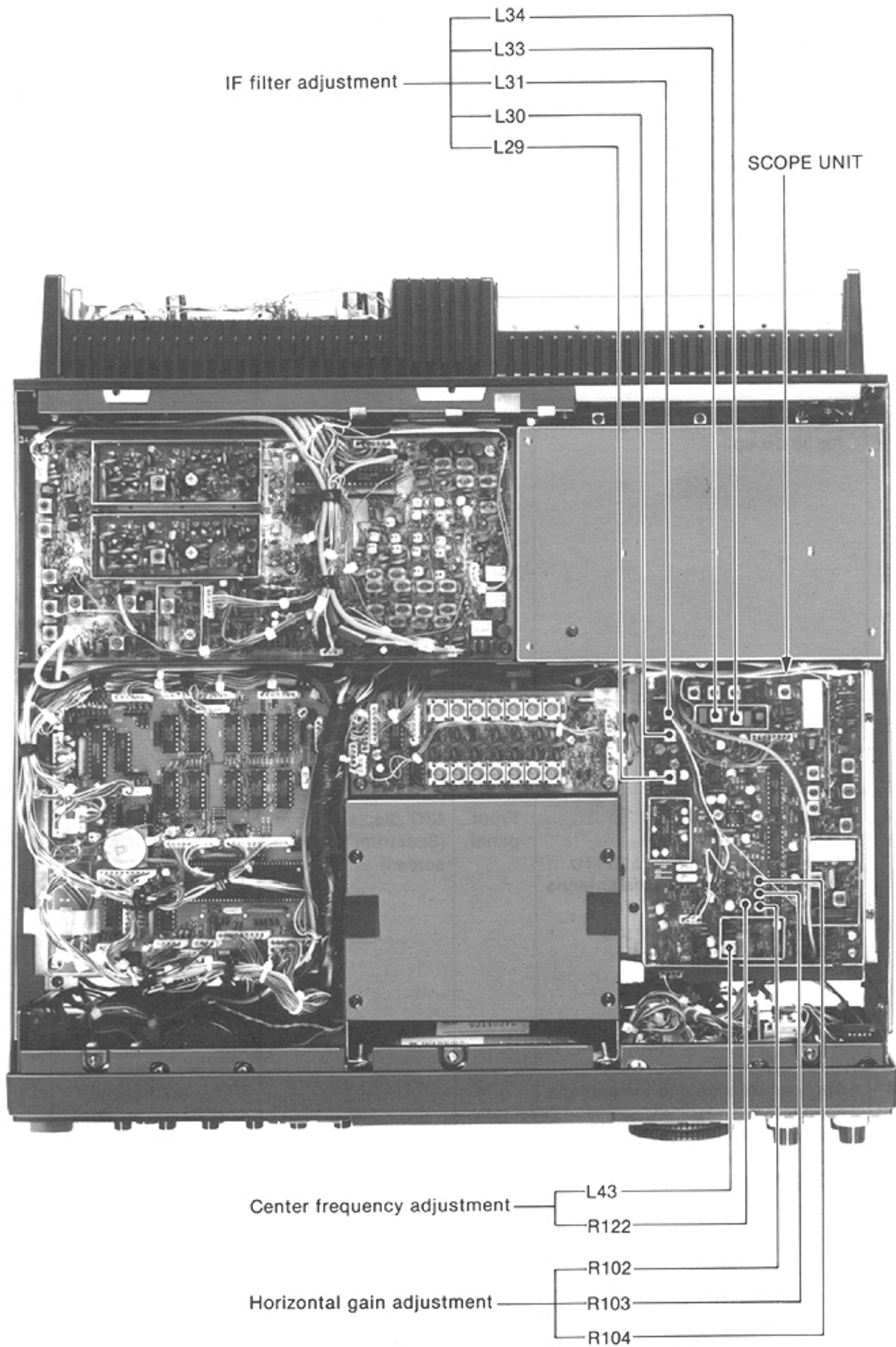



## SPECTRUM SCOPE ADJUSTMENT (CONTINUED)

ADJUSTMENT	ADJUSTMENT CONDITIONS	MEASUREMENT		VALUE	ADJUSTMENT POINT			
		UNIT	LOCATION		UNIT	ADJUST		
VERTICAL SCALE	1	<ul style="list-style-type: none"> <li>Operating frequency: 14.10000 MHz</li> <li>[AGC OFF] switch: ON (IN position)</li> <li>Spectrum bandwidth: <math>\pm 25</math> kHz</li> <li>Apply an RF signal to the antenna connector.</li> </ul>	Front panel	CRT display (Spectrum Scope screen)	Adjust as follows:	Applied RF signal level		
	2	<ul style="list-style-type: none"> <li>Adjust the applied RF signal level for 30 dB up.</li> </ul>			Adjust as follows:		SCOPE	R80
	NOTE: Repeat above adjustments 1 and 2 several times.							
	3	<ul style="list-style-type: none"> <li>Operating frequency: 14.10000 MHz</li> <li>Spectrum bandwidth: <math>\pm 25</math> kHz</li> <li>Apply an RF signal to the antenna connector. Level: <math>-63</math> dBm (160 <math>\mu</math>V) Mod.: OFF</li> </ul>	Front panel	CRT display (Spectrum Scope screen)	Verify as follows:	Verify		
	4	<ul style="list-style-type: none"> <li>Apply an RF signal to the antenna connector. Level: <math>-33</math> dBm (5 mV)</li> <li>[AGC OFF] switch: OFF</li> <li>[AGC] control: Center</li> </ul>			Adjust so that the peak nearly touches the top of the screen.		R75	
	5	<ul style="list-style-type: none"> <li>Apply an RF signal to the antenna connector. Level: <math>-73</math> dBm (50 <math>\mu</math>V)</li> <li>[AGC OFF] switch: ON (IN position)</li> </ul>			Adjust as follows:		R48	

# SCOPE UNIT

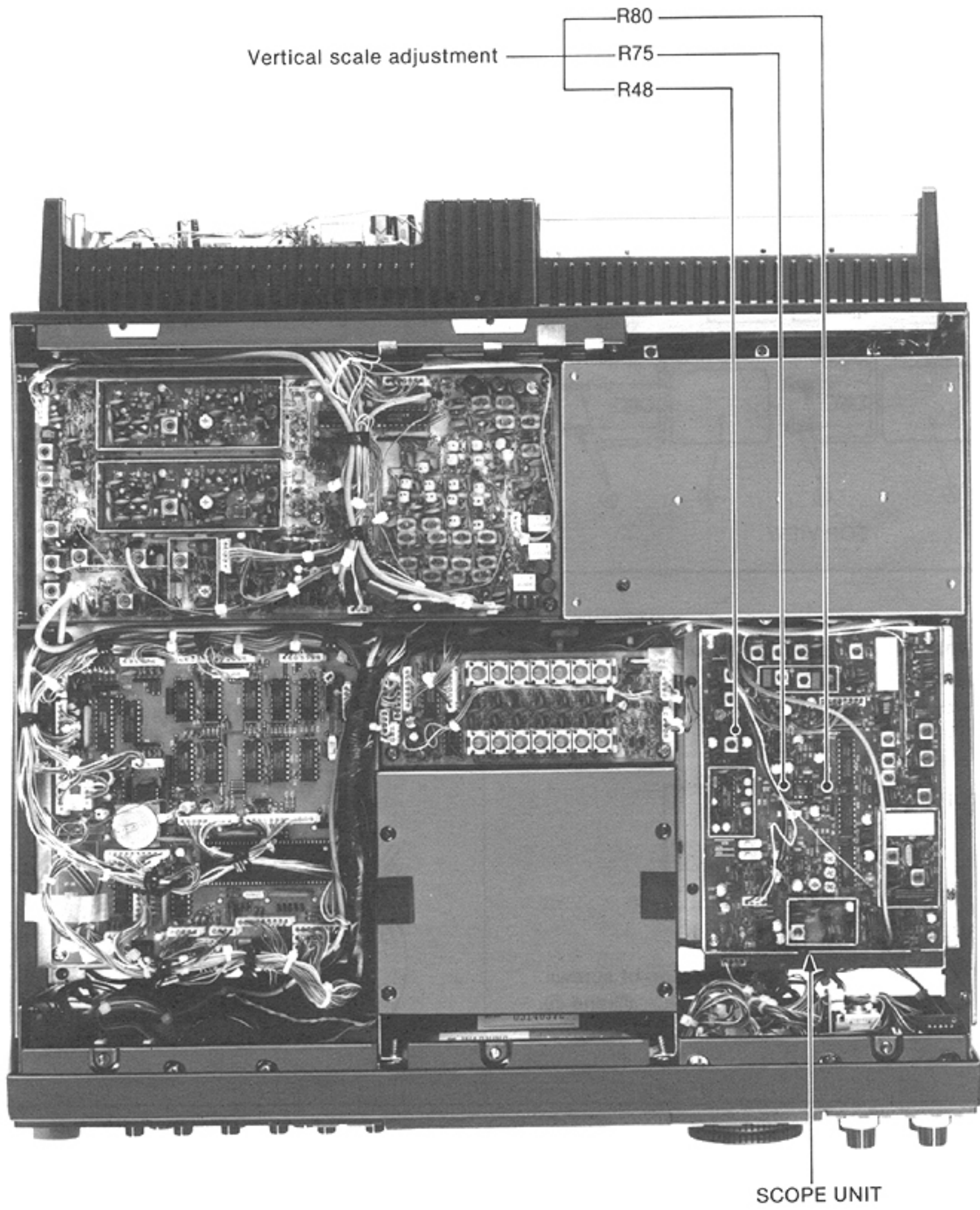

# 6-7 TUNER UNIT ADJUSTMENT

## MATCHING CAPACITOR SECTION

### 1. COARSE ADJUSTMENT

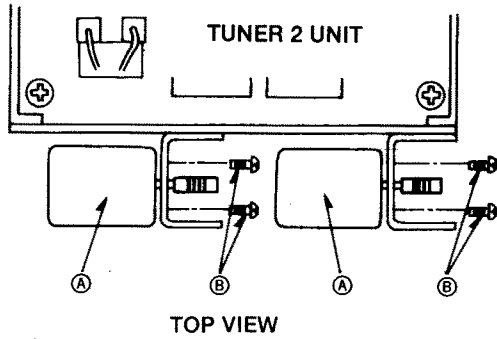
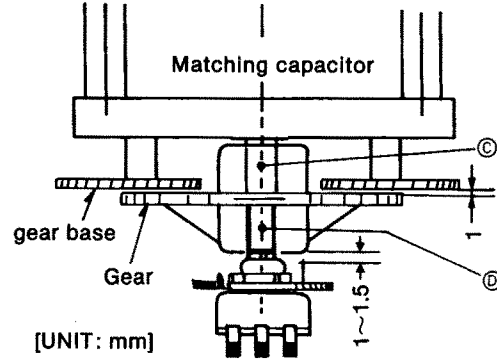
<p>① Remove the matching capacitor motors (A) by removing screws (B).</p>	<p>② Loosen screws (C) and (D). ③ Align each part position, as shown below.</p>
 <p>TUNER 2 UNIT TOP VIEW</p>	 <p>Matching capacitor gear base Gear [UNIT: mm] 1.5</p>

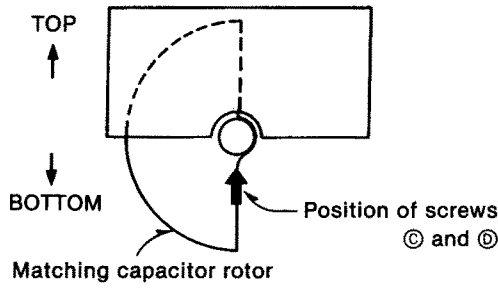
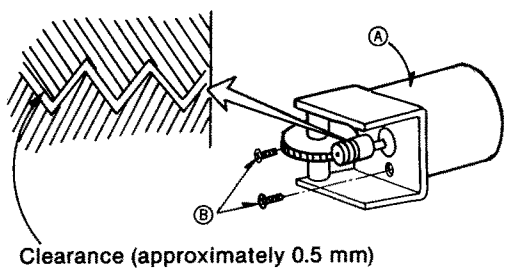
<p>④ Set the matching capacitor rotors and gears as shown below.</p>	<p>⑤ Tighten screws (C) and (D). ⑥ Attach the matching capacitor motors (A), and adjust their positions as shown below. ⑦ Tighten screws (B).</p>
 <p>TOP BOTTOM Position of screws (C) and (D) Matching capacitor rotor</p>	 <p>Clearance (approximately 0.5 mm)</p>

### 2. FINE ADJUSTMENT

ADJUSTMENT	ADJUSTMENT CONDITIONS	MEASUREMENT		VALUE	ADJUSTMENT POINT	
		UNIT	LOCATION		UNIT	ADJUST
MATCHING CAPACITORS	1 <ul style="list-style-type: none"> <li>• Operating frequency: 14.10000 MHz</li> <li>• FM mode</li> <li>• PRESET mode</li> <li>• Transmitting</li> <li>• Preset controls (for 14 MHz): Max. CCW*</li> </ul>	TUNER	Matching capacitor	$\theta = \theta'$	TUNER	SCREWS (D)
	2 <ul style="list-style-type: none"> <li>• Preset controls (for 14 MHz): Max. CW*</li> </ul>		Matching capacitor			
<p>NOTE: Adjust the matching capacitors so that the angles <math>\theta</math> and <math>\theta'</math> become equal to each other by tightening and loosening screws (D) as necessary. After completing the adjustment, tighten screws (D).</p>						

\* CW: Clockwise \* CCW: Counterclockwise

# DETECTOR SECTION

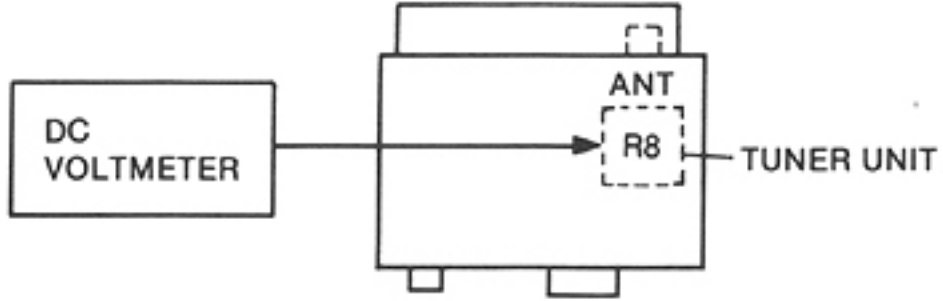
REQUIRED TEST EQUIPMENT		TEST EQUIPMENT HOOK-UP				
(1) DC VOLTMETER • Input impedance : 50 kΩ/DC or better						
ADJUSTMENT	ADJUSTMENT CONDITIONS	MEASUREMENT		VALUE	ADJUSTMENT POINT	
		UNIT	LOCATION		UNIT	ADJUST
DETECTOR	1	TUNER 2	Connect a DC voltmeter to R8.	0 V	TUNER 2	C44
NOTE: After completing the adjustment, remove the coaxial cable and re-solder W311 and W312.						

## TUNER UNIT

### • TOP VIEW

TUNER 2 UNIT

C44 Detector adjustment  
R8 Detector check point

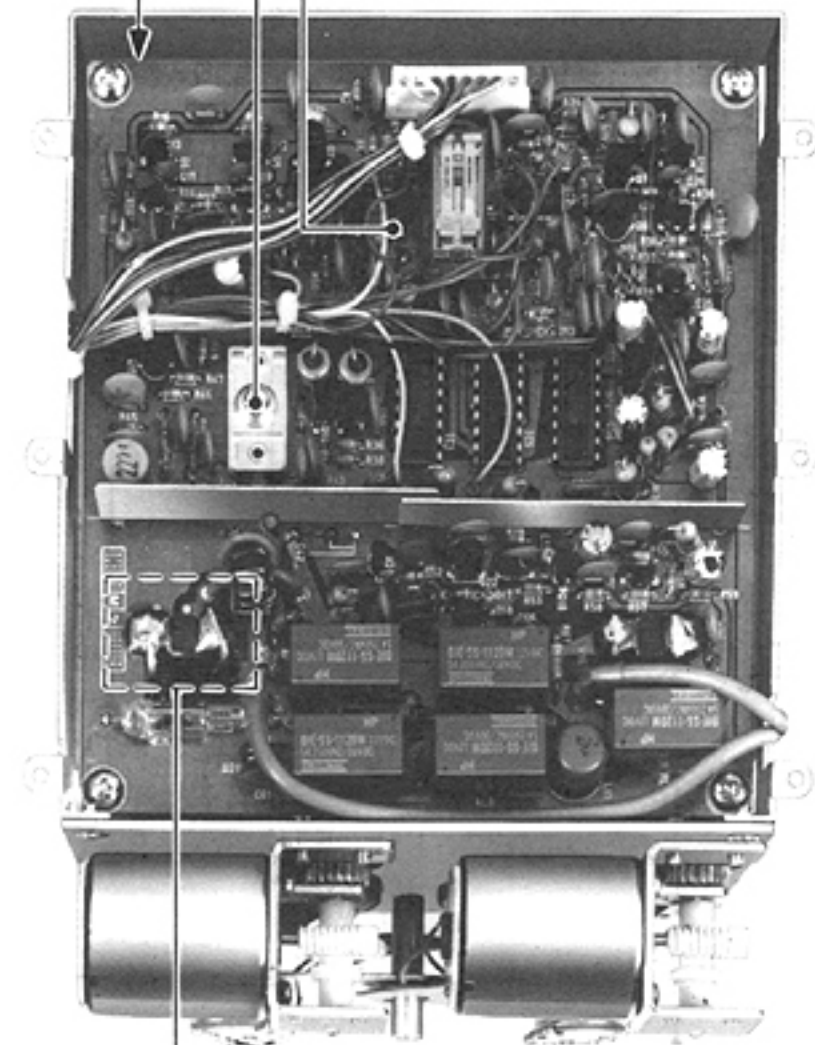

Detector presetting

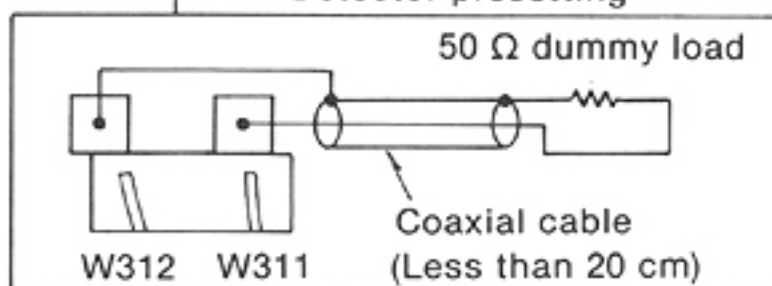

### • BOTTOM VIEW

TUNER 1 UNIT

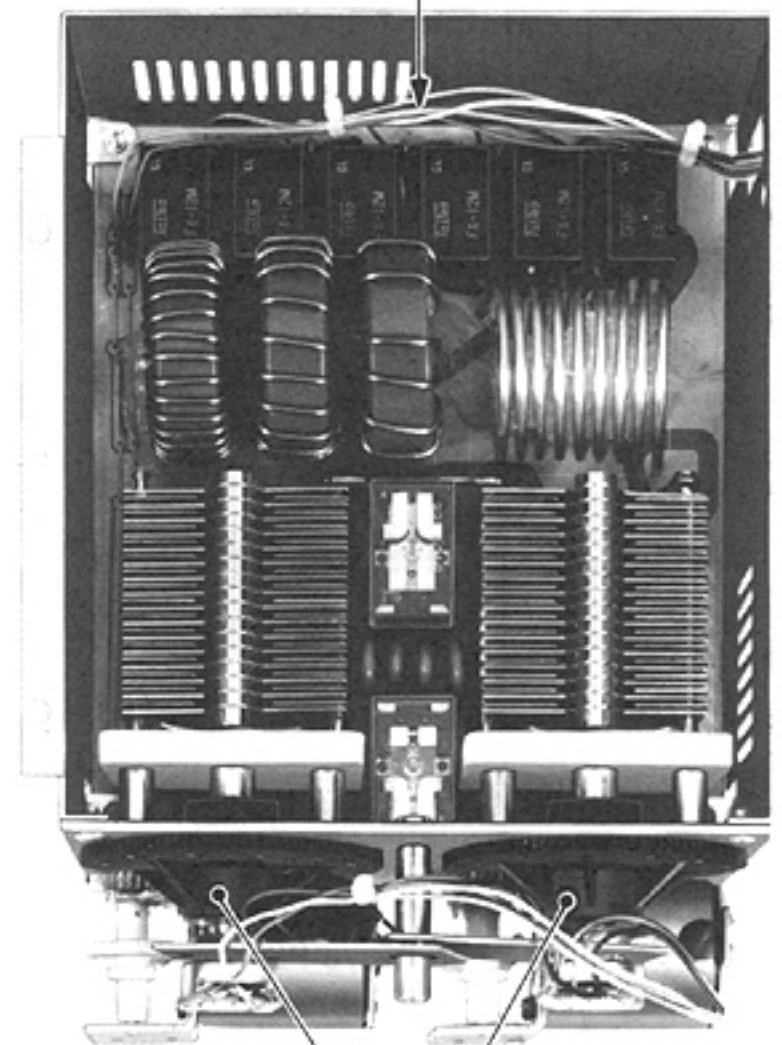

Screws ①

## 6-8 SWITCHING REGULATOR ADJUSTMENT

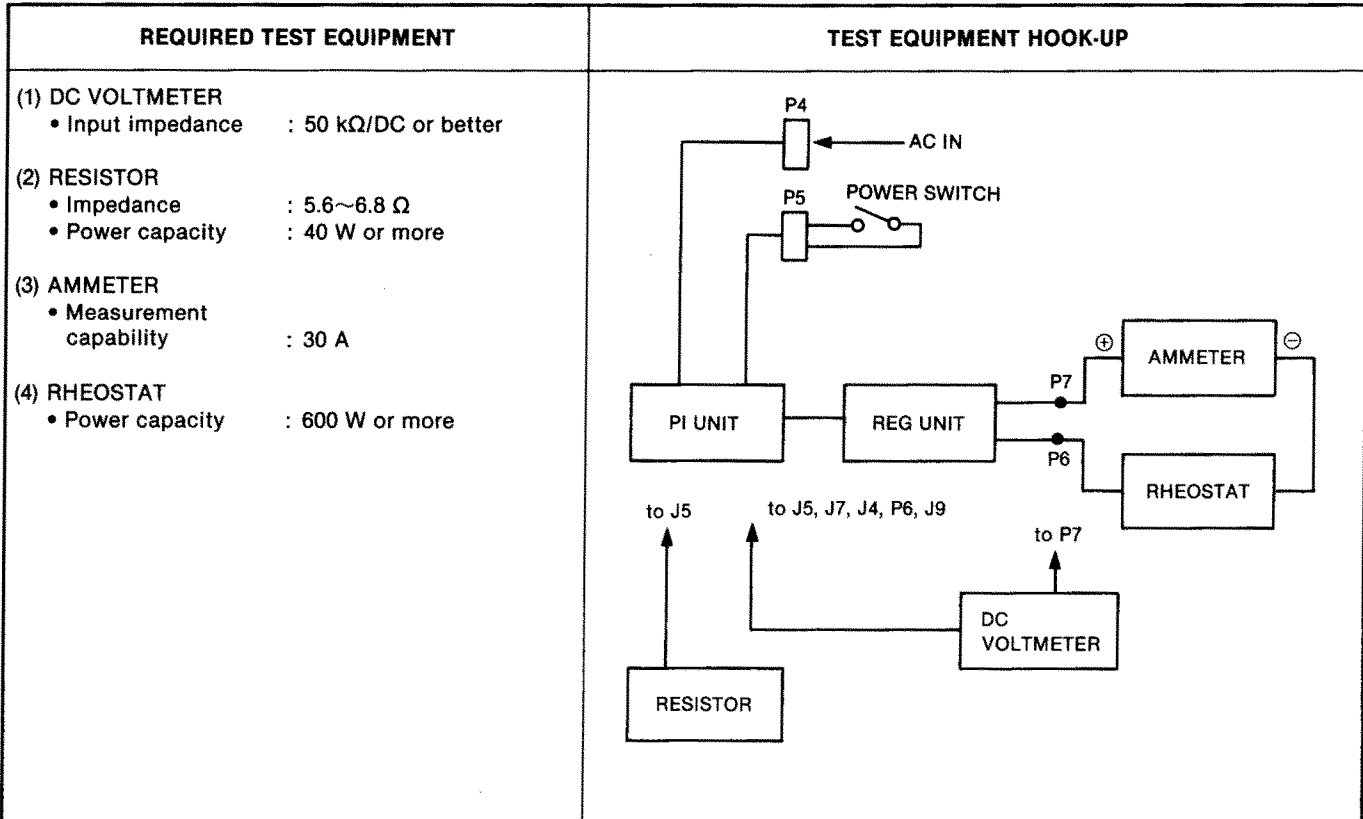

ADJUSTMENT	ADJUSTMENT CONDITIONS	MEASUREMENT		VALUE	ADJUSTMENT POINT		
		UNIT	LOCATION		UNIT	ADJUST	
OUTPUT VOLTAGE	<ul style="list-style-type: none"> <li>• Unplug P40, P42 and P45 from the PI UNIT.</li> <li>• Unplug P6 from the DISPLAY UNIT.</li> <li>• Connect the resistor between J5 pin 1 and ground.</li> <li>• R2 (REG): Max. CCW*</li> <li>• R6 (REG): Max. CW*</li> <li>• [TIMER] switch: OFF</li> <li>• [POWER] switch: ON</li> </ul>	PI	Connect the DC voltmeter to J5 pin 1.	15.0 V	REG	R2	
			Connect the DC voltmeter to J7 pin 1.	5 V			Verify
			Connect the DC voltmeter to J7 pin 8.	9 V			
			Connect the DC voltmeter to J4 pin 1.	-9 V			
			Connect the DC voltmeter to P6 pin 1.	12 V			
			Connect the DC voltmeter to J9 pin 1.	32 V			
CURRENT PROTECTOR	<ul style="list-style-type: none"> <li>• Connect the resistor between J5 pin 1 and ground.</li> <li>• Remove P6 and P7 from the PA UNIT and connect the rheostat.</li> </ul>	REG	Connect the ammeter between the rheostat and P7.	18 A	Rheostat		
			Connect the DC voltmeter to P7.	Turn R6 CW* for a point just before the output voltage drops.	REG	R6	
NOTE: After completing the adjustment, remove the resistor and rheostat and then return P6 (PI), P6 (REG), P7, P40, P42 and P45 to their original conditions.							

\* CW: Clockwise \* CCW: Counterclockwise



## REG UNIT

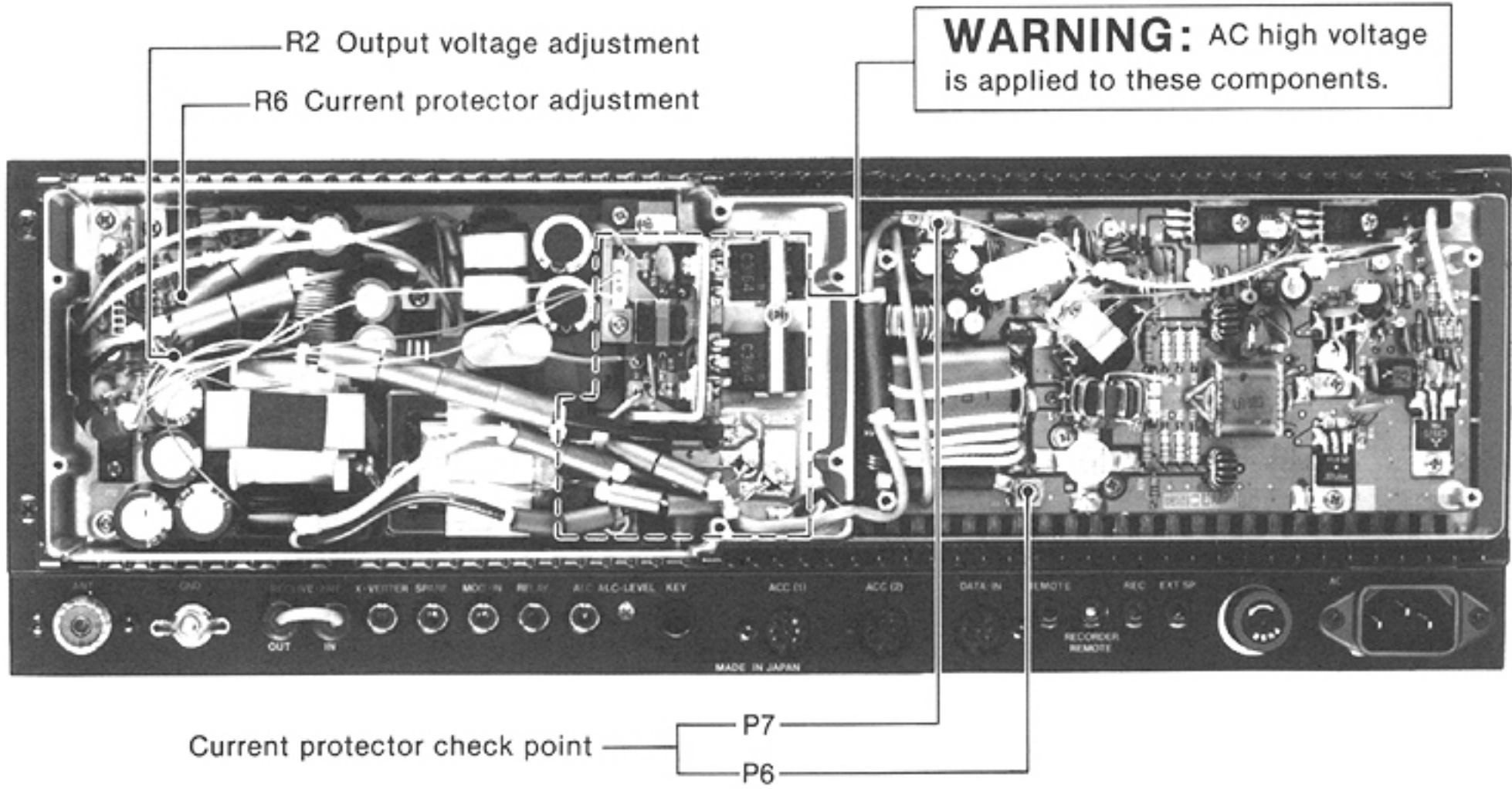

## UNIT LOCATION

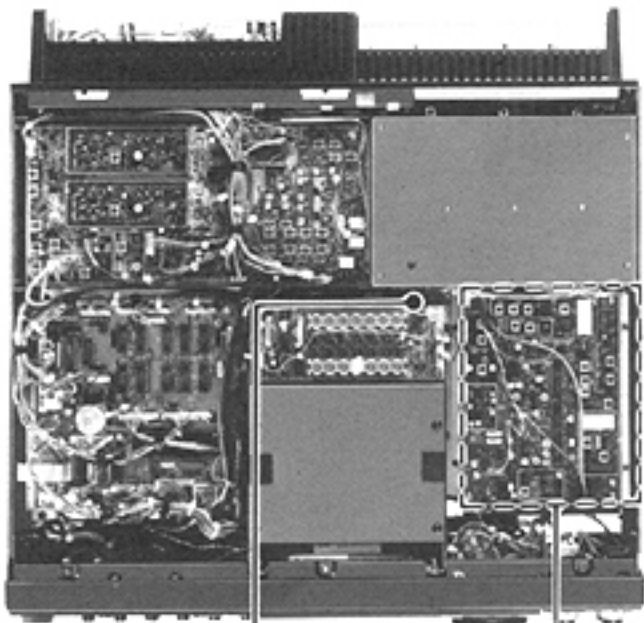

P6 Output voltage check point (See below.)

The PI UNIT is located under the SCOPE UNIT.

Pin 1 (P6) Output voltage check point.

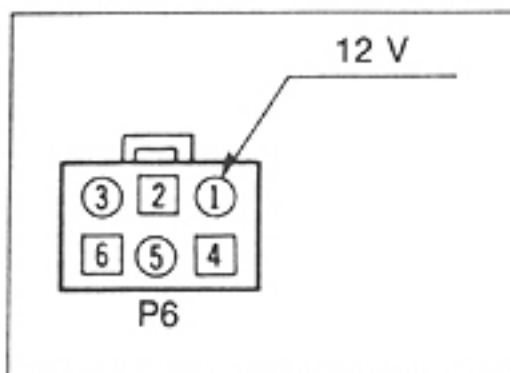

## PI UNIT

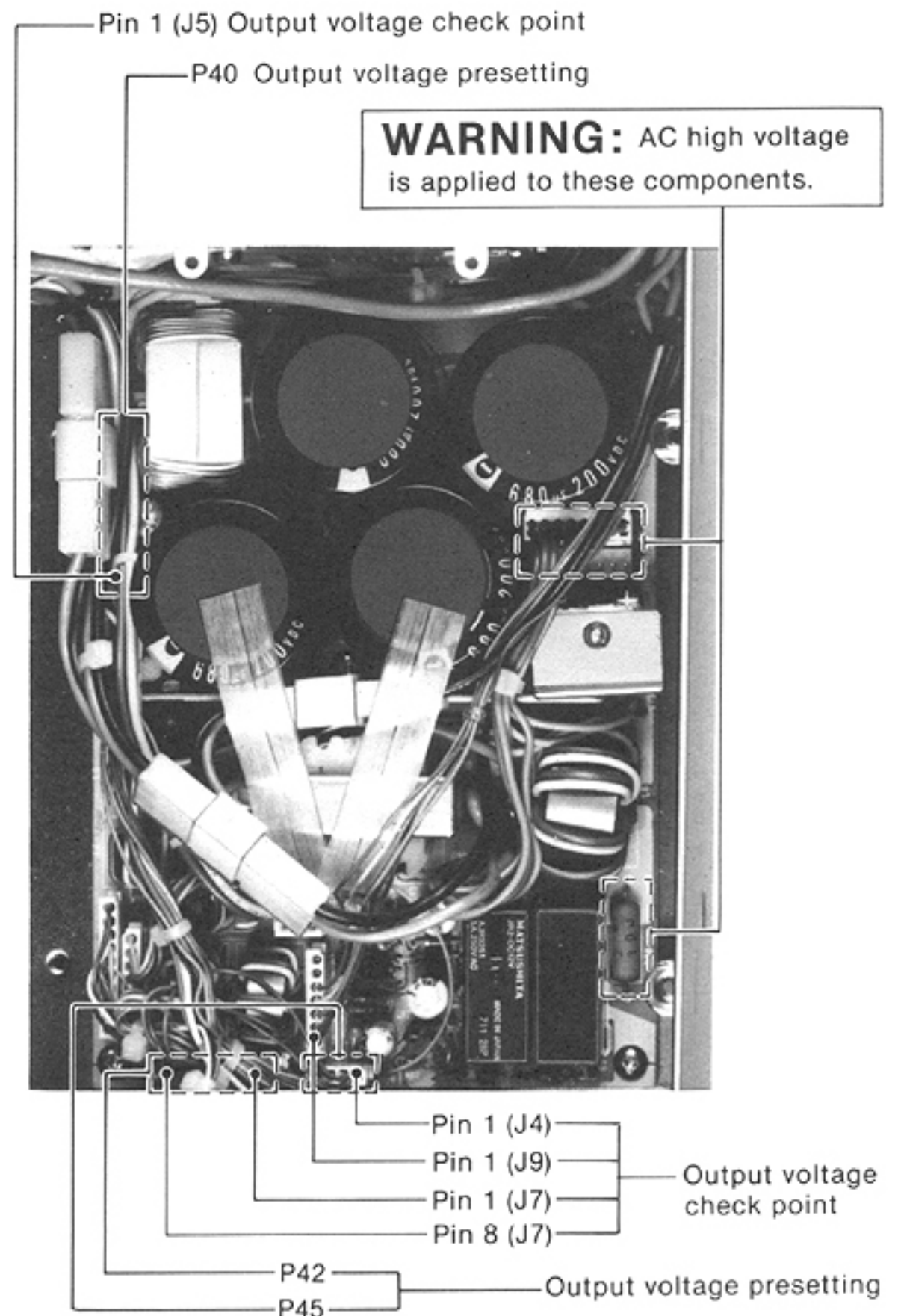

# SECTION 7 BOARD LAYOUTS

## 7-1 FRONT UNIT (1)

### • SENSOR UNIT

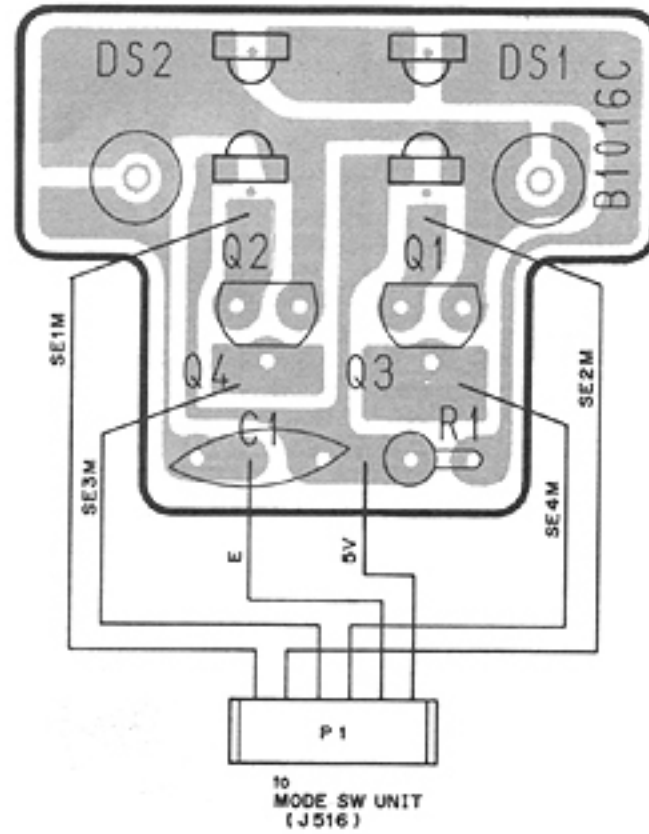

1S433  
Q1, Q2

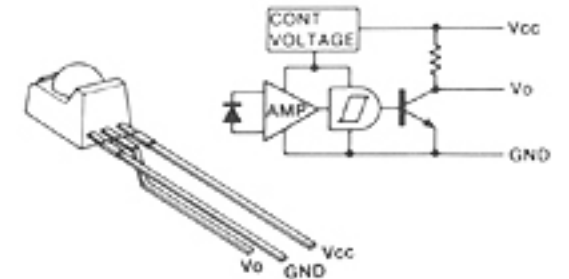

RN1204  
Q3, Q4

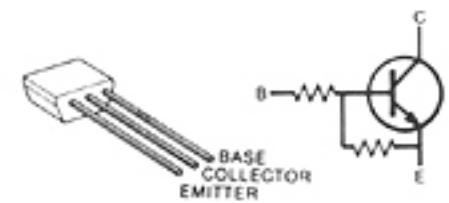

### • LED UNIT

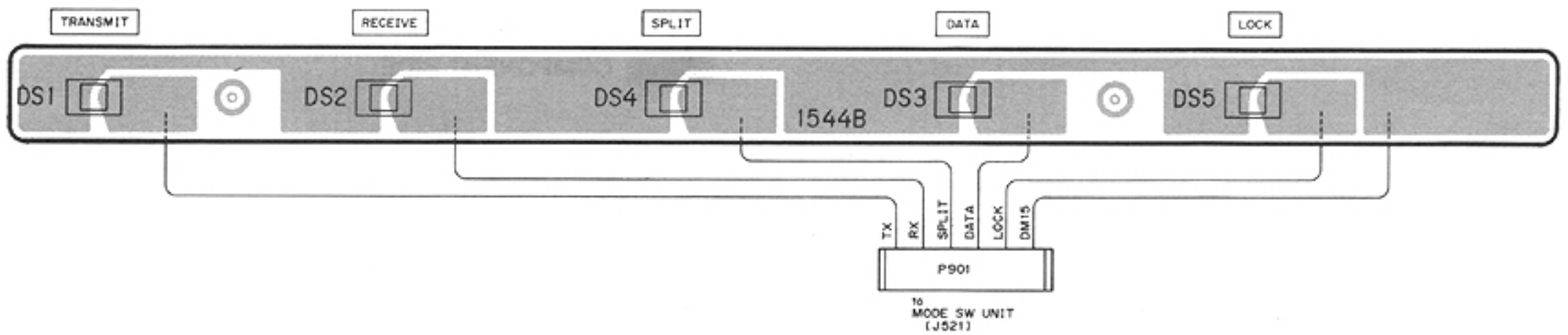

NOTE: Add "900" to the indicated number on the unit for actual part number respectively.

### • PHONES

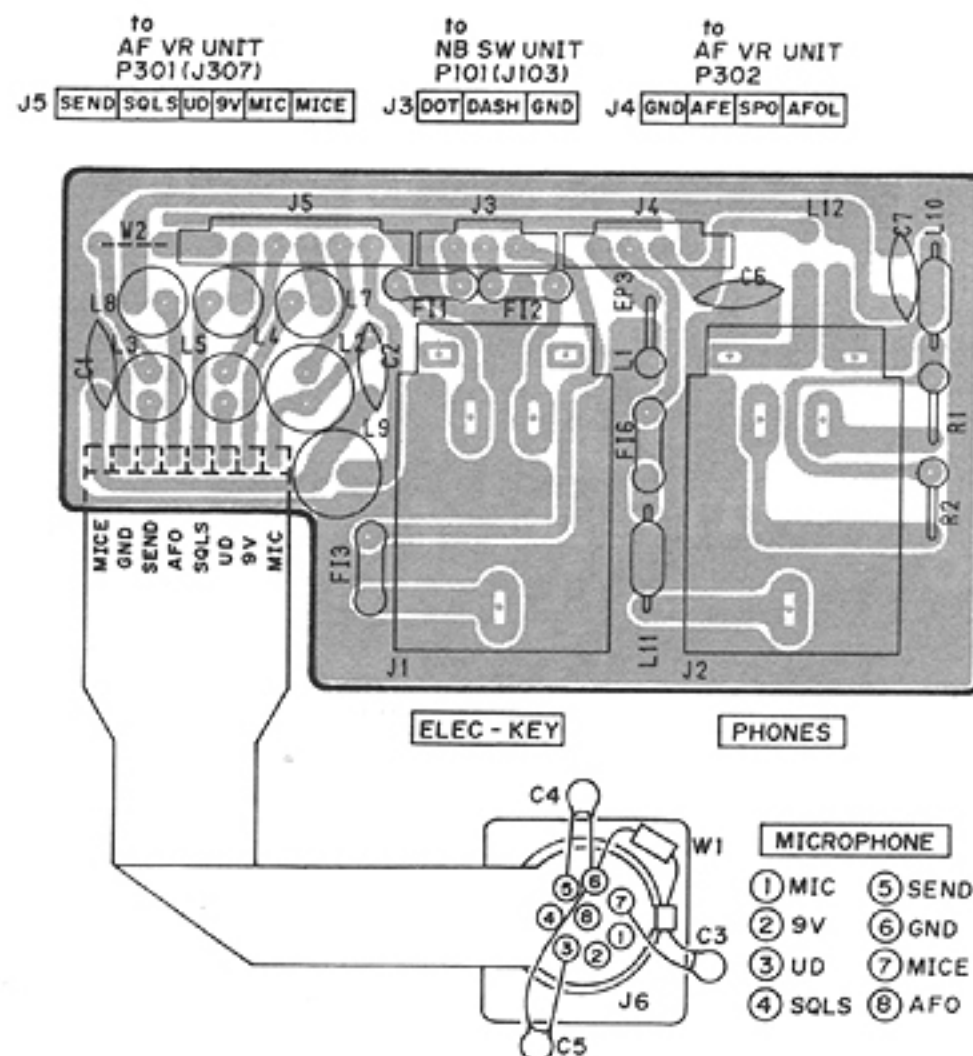



• BRIGHT VR UNIT

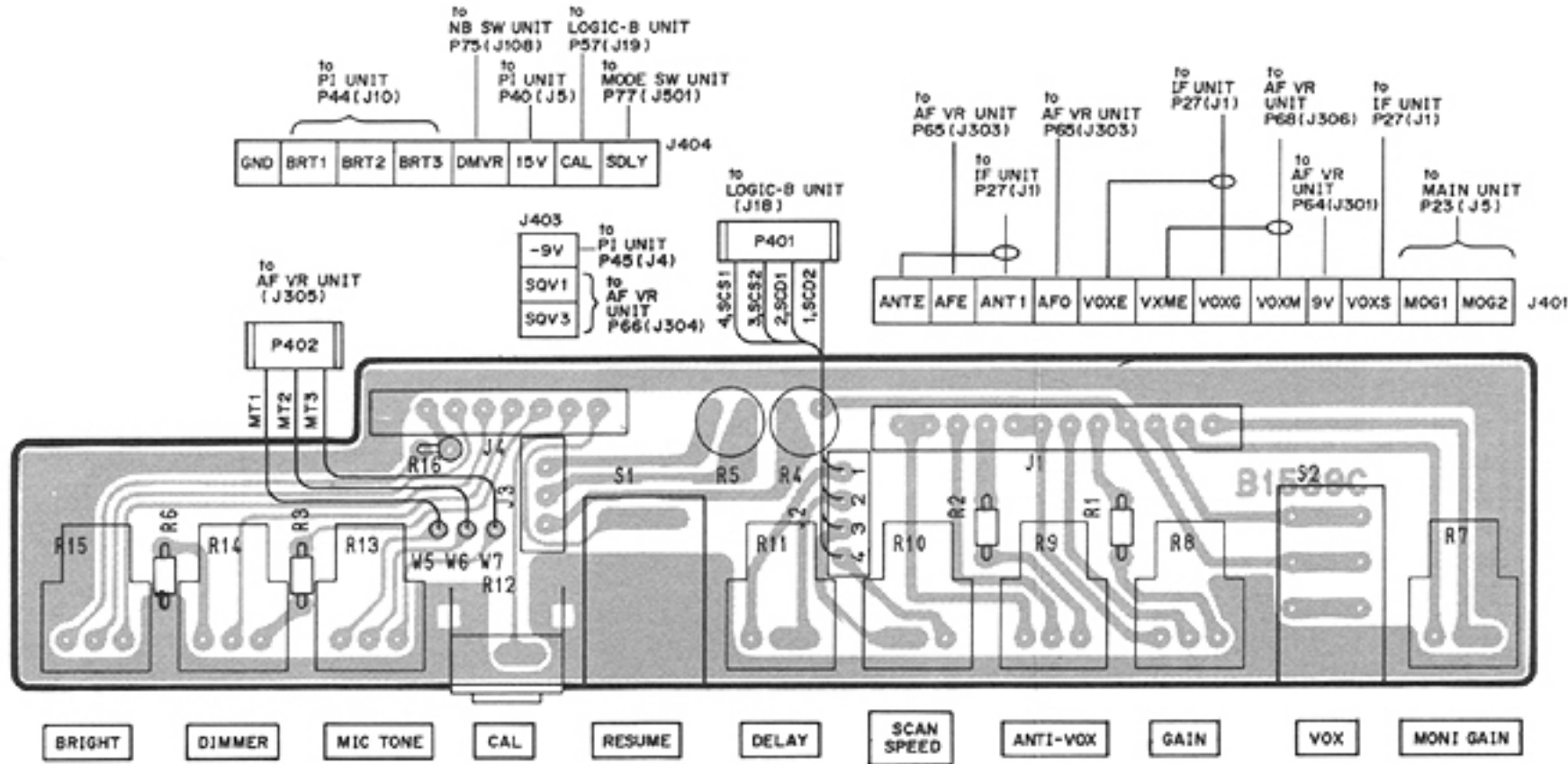

NOTE: Add "400" to the indicated number on the unit for actual part number respectively.

• AF VR UNIT

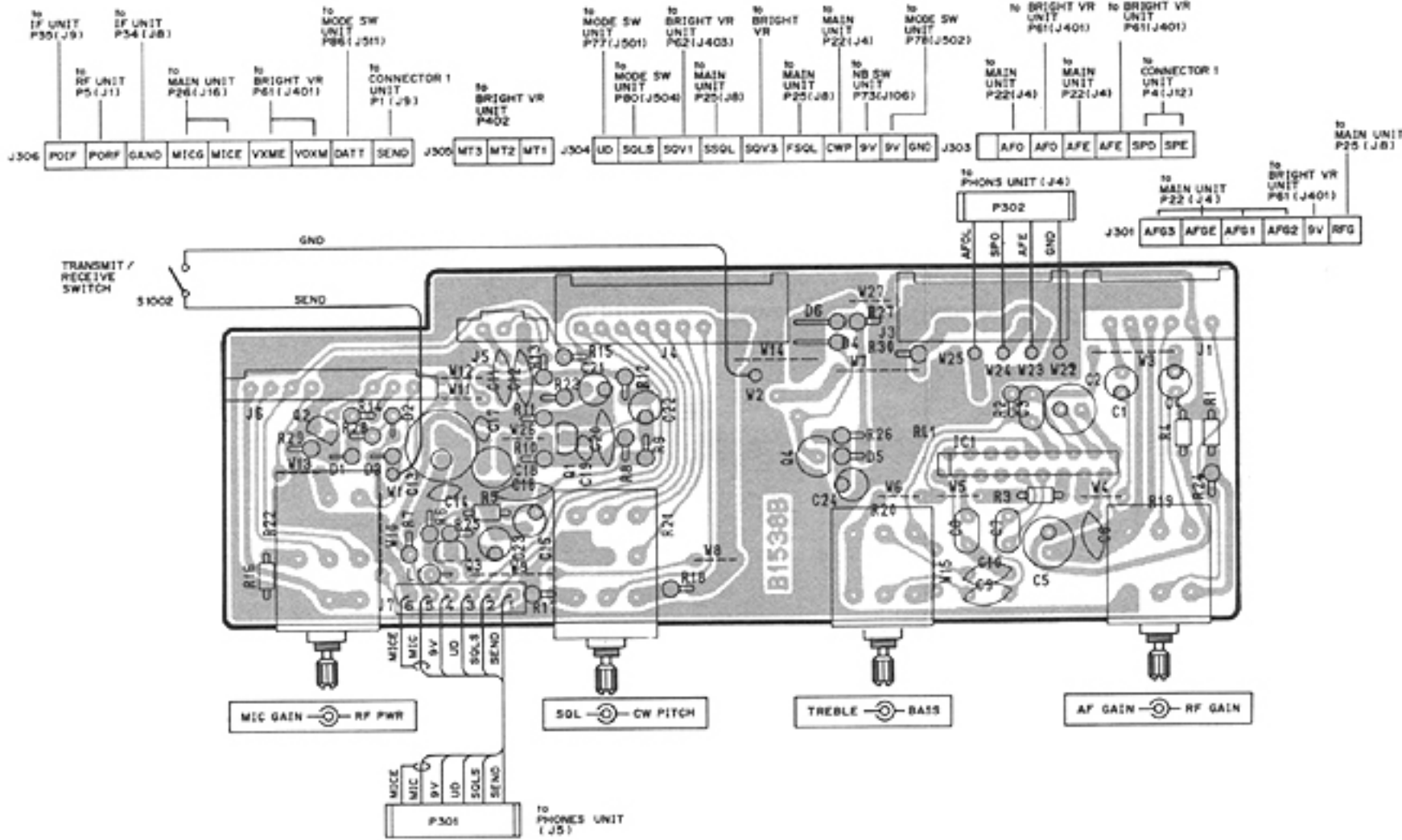

NOTE: Add "300" to the indicated number on the unit for actual part number respectively.

2SC1571 G  
Q301

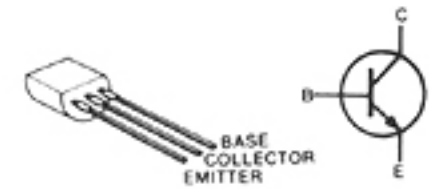

2SC1645 B  
Q304

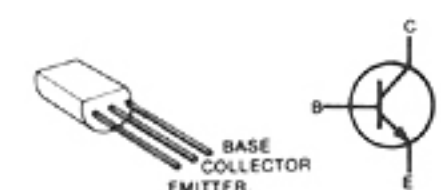

2SC2878  
Q302



2SD468 C  
Q303





## 7-2 FRONT UNIT (2)

### • KEYBOARD UNIT COMPONENT SIDE

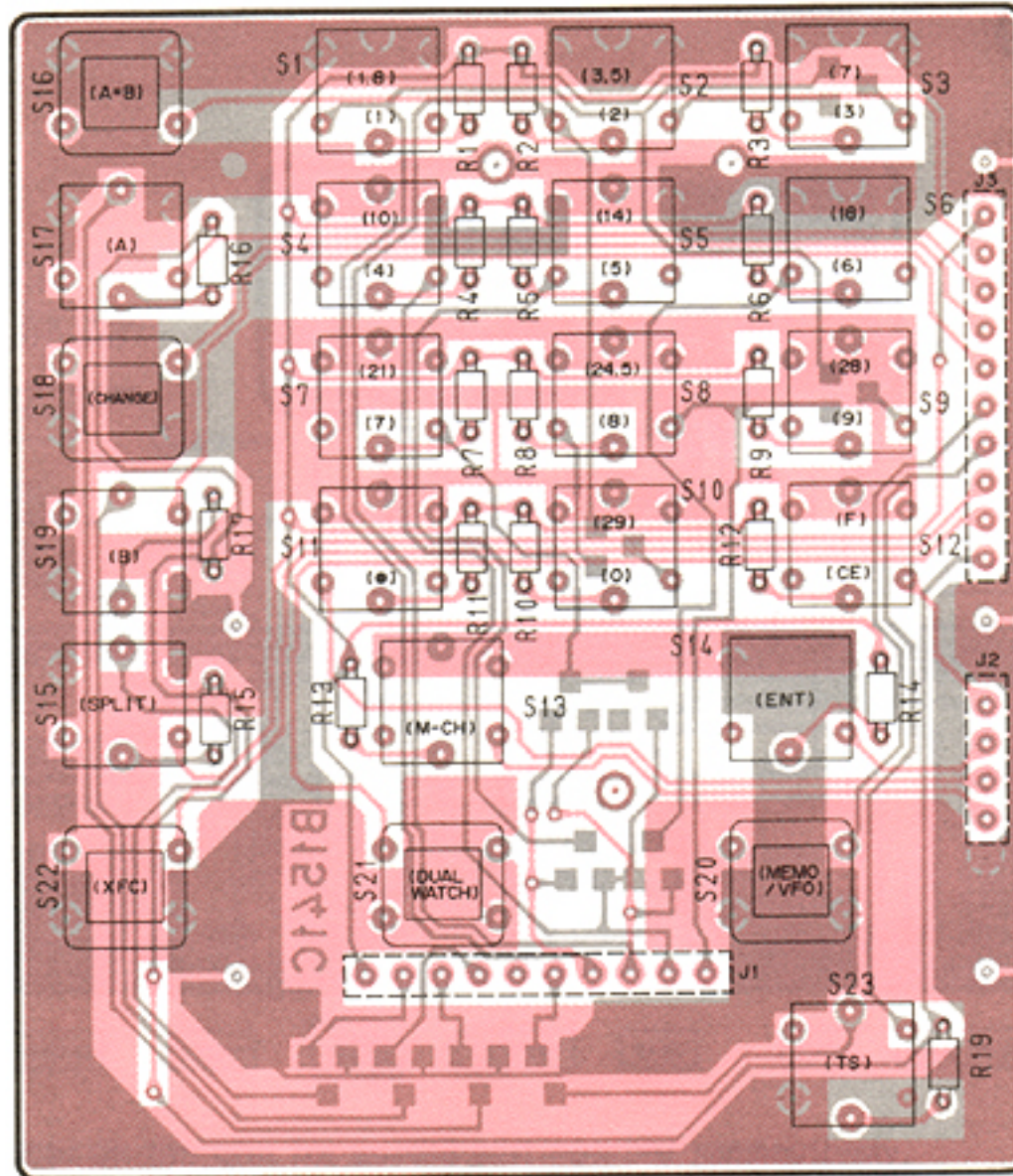

FOIL SIDE  
 COMPONENT SIDE

### FOIL SIDE

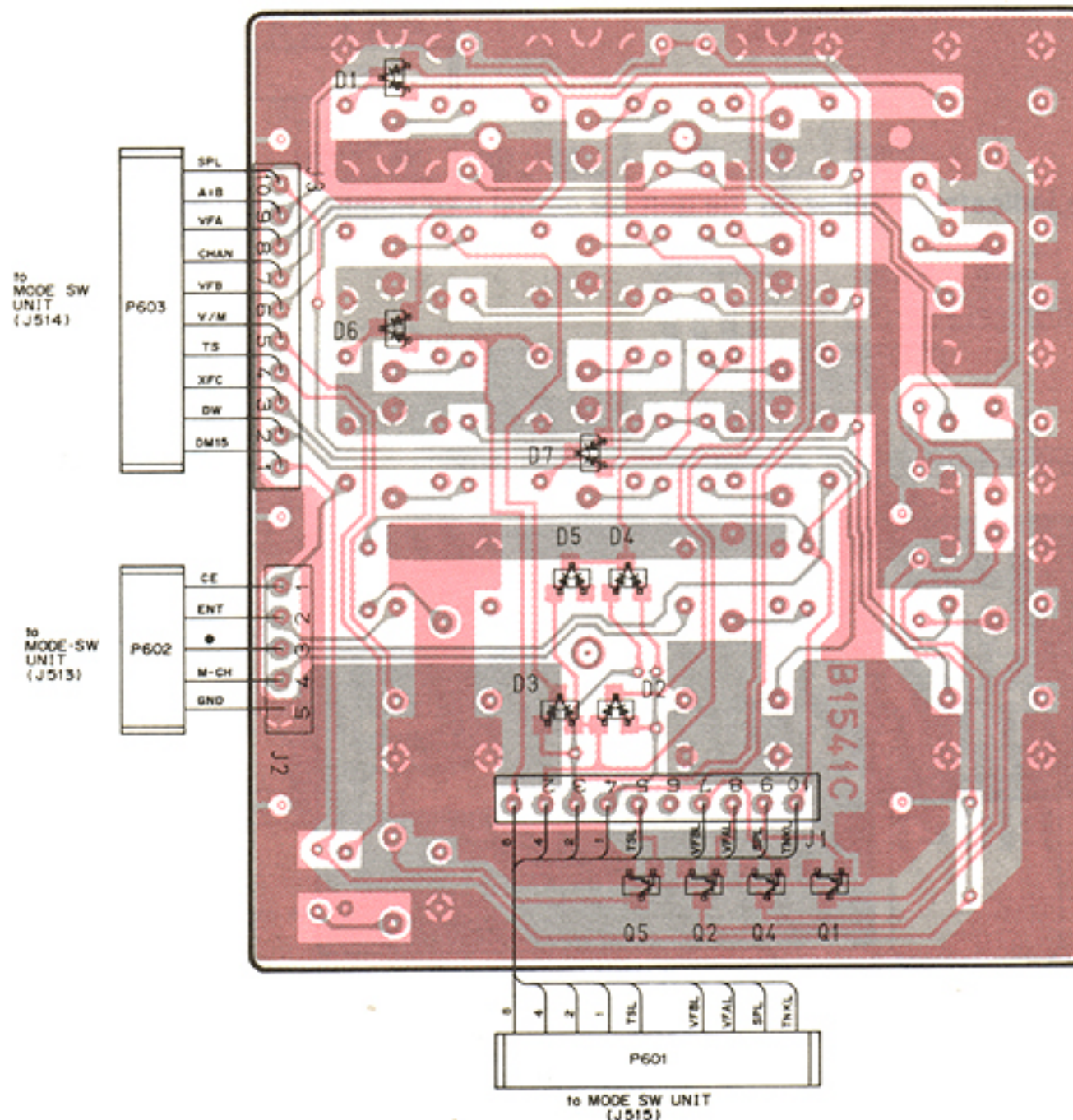

**RN1404**  
 Q601, Q602  
 Q603, Q604

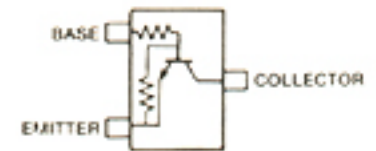

Symbol: XD

**1SS184**  
 D601, D602  
 D603, D604  
 D605, D606  
 D607

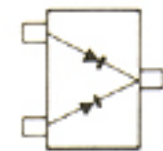

Symbol: B3

FOIL SIDE  
 COMPONENT SIDE

**NOTE:** Add "600" to the indicated number on the unit for actual part number respectively.



• NB SW UNIT  
COMPONENT SIDE

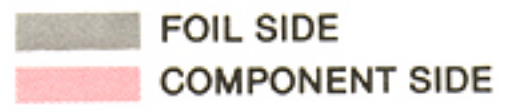
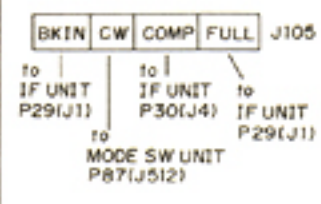
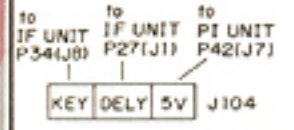
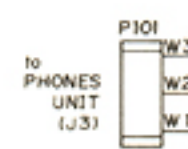
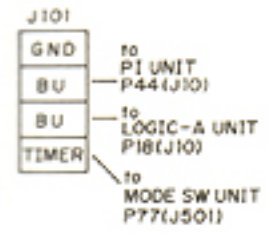
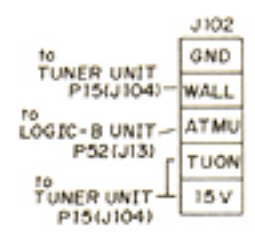
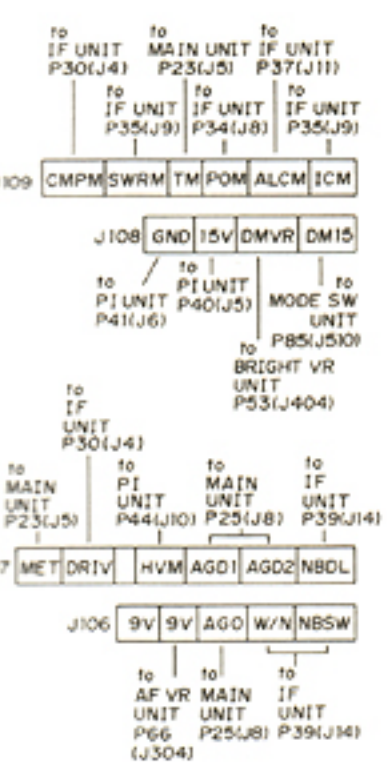
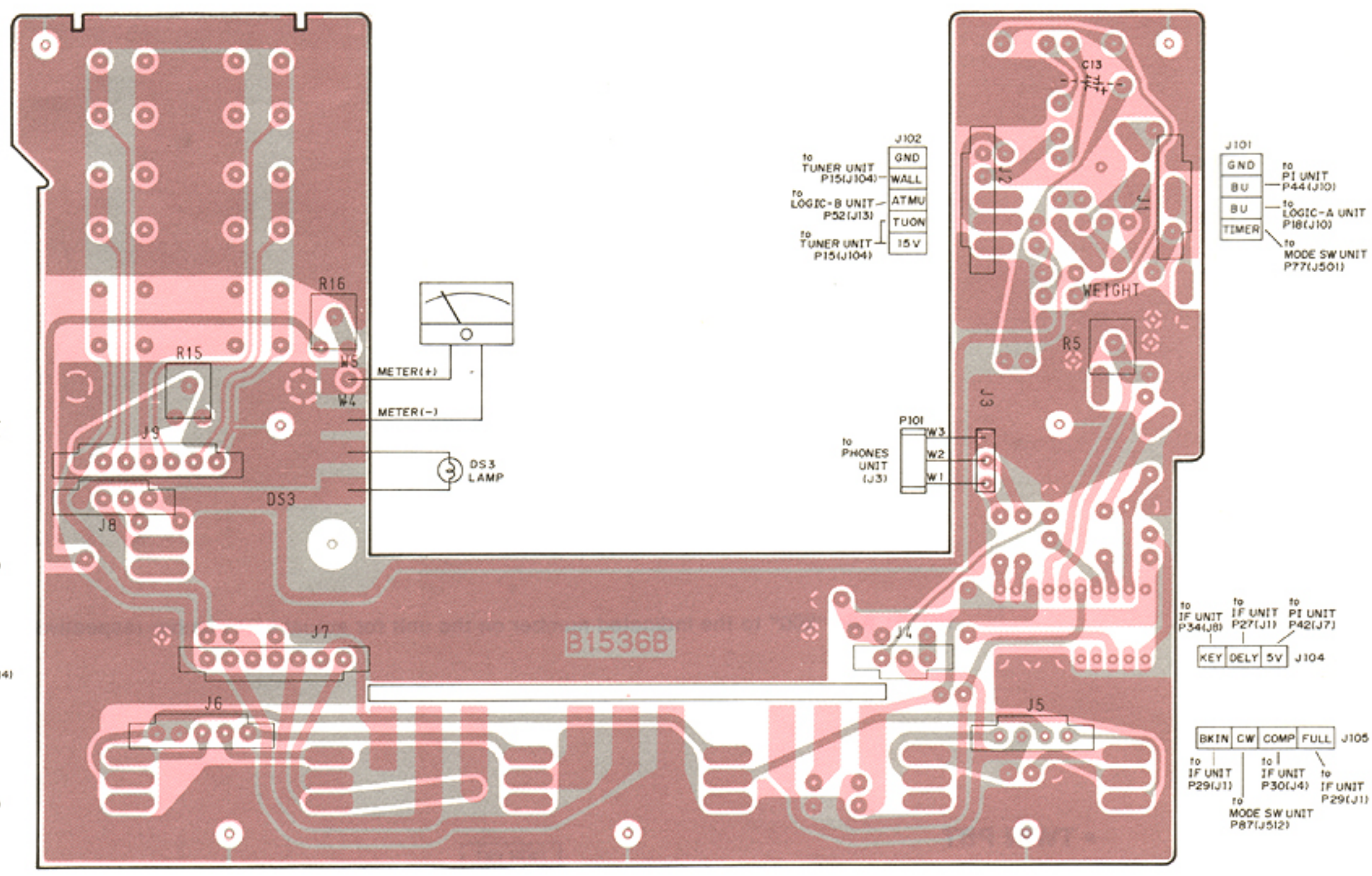

2SC2458 Y  
Q105

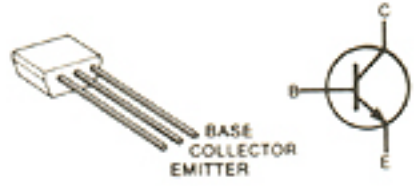

2SD468 C  
Q103



2SD1406 Y  
Q106

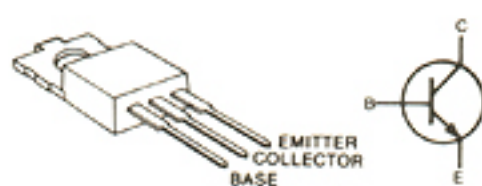

RN1202  
Q104

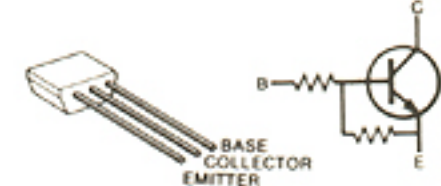

RN1204  
Q101, Q102

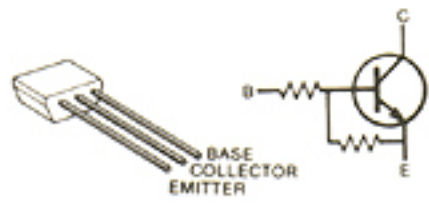

NOTE: Add "100" to the indicated number on the unit for actual part number respectively.



**FOIL SIDE**

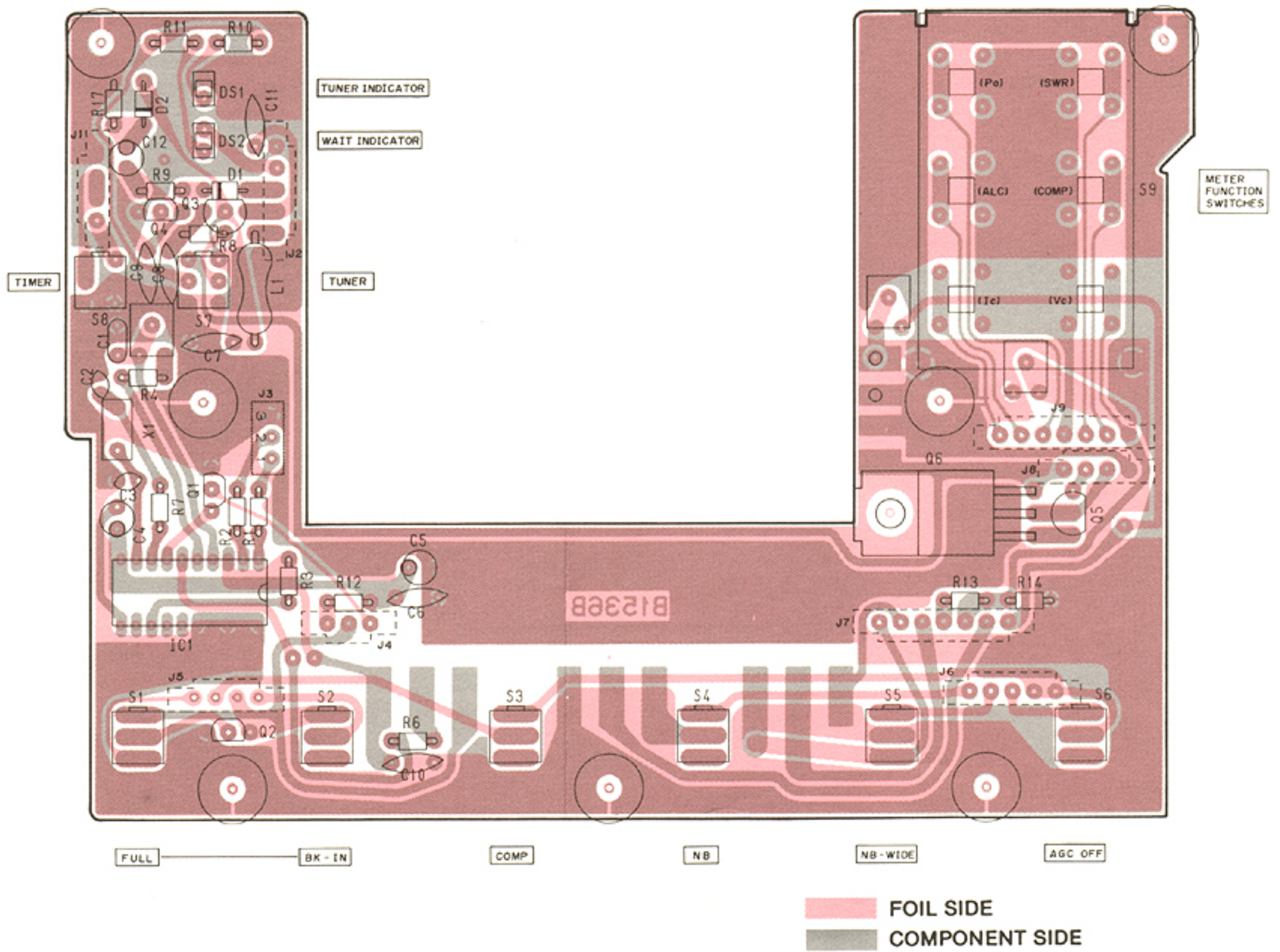

**• NB VR UNIT**

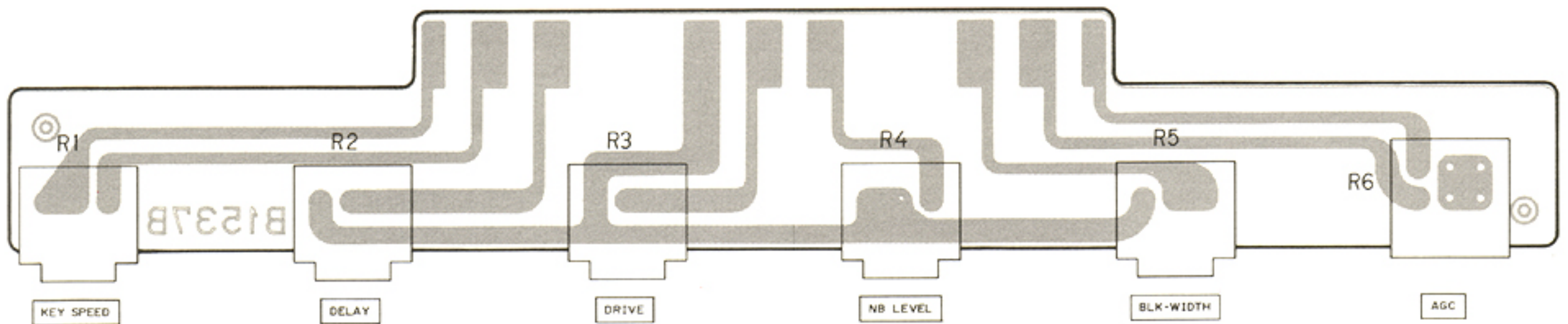

**NOTE:** Add "200" to the indicated number on the unit for actual part number respectively.

## 7-3 FRONT UNIT (3)

### • NOTCH/APF CONTROL

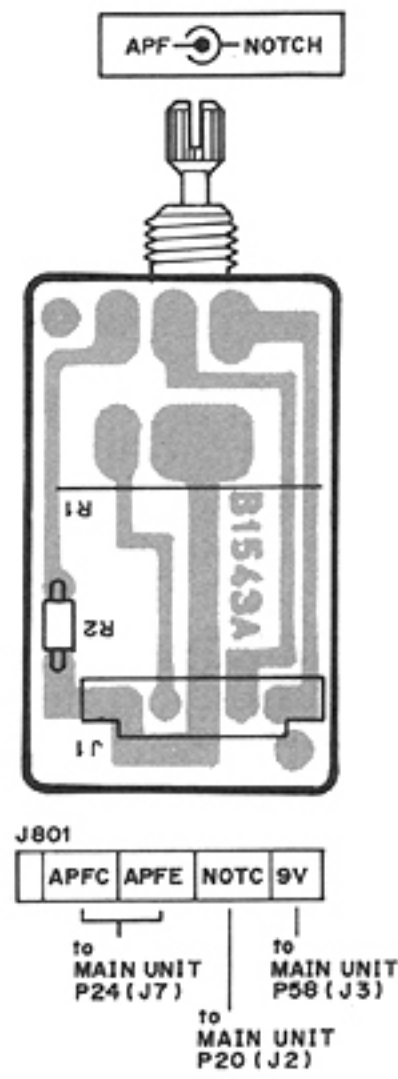

NOTE: Add "800" to the indicated number on the unit for actual part number respectively.

### • TWIN PBT

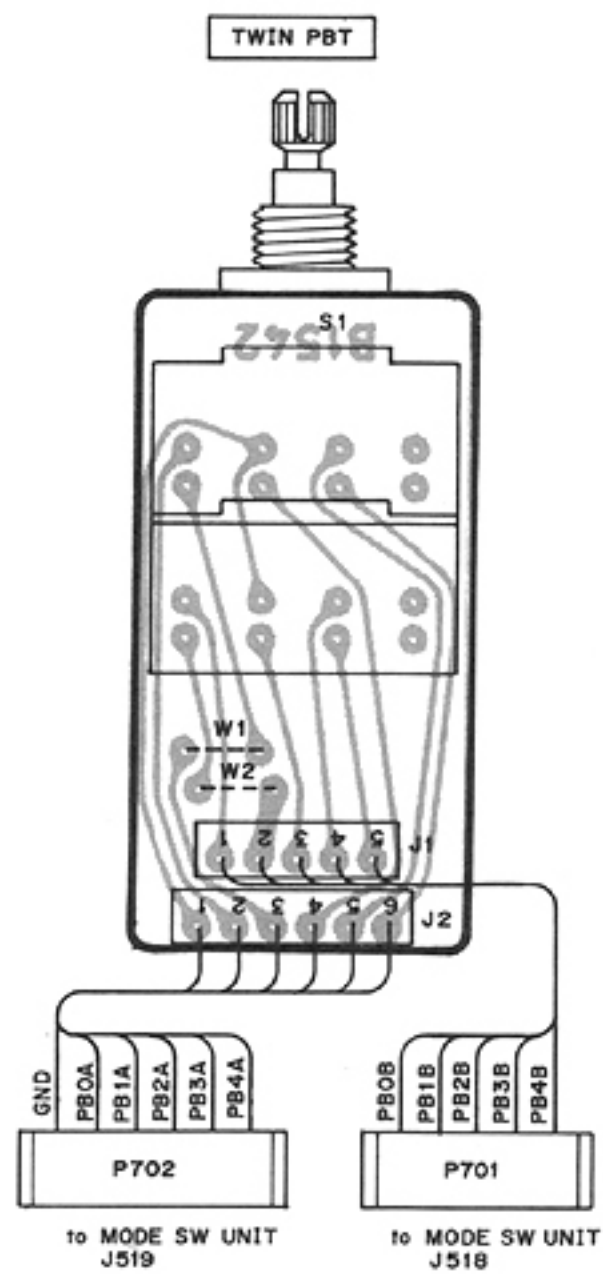

NOTE: Add "700" to the indicated number on the unit for actual part number respectively.



• MODE SW UNIT

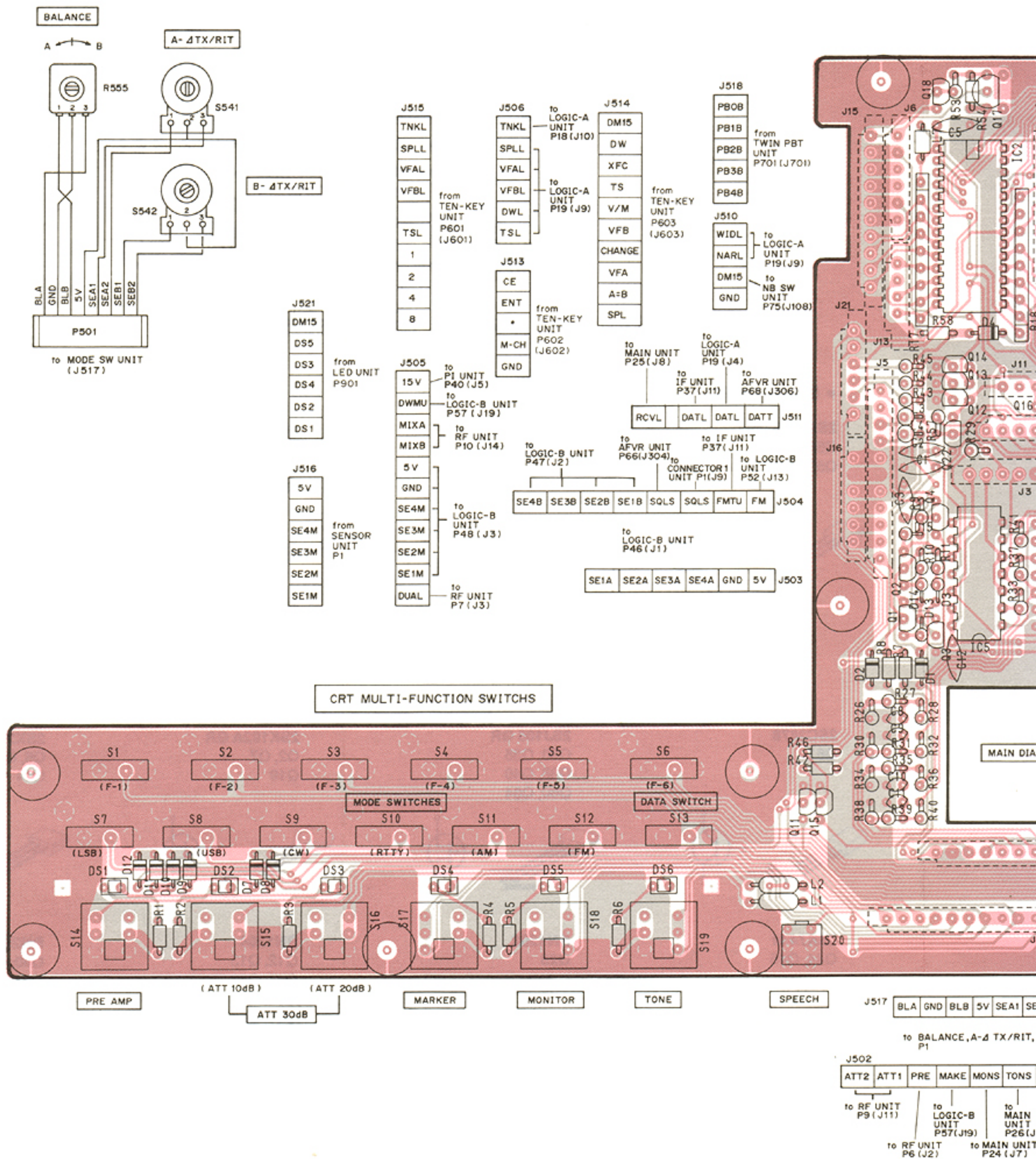

NOTE: Add "500" to the indicated number on the unit for actual part number respectively.



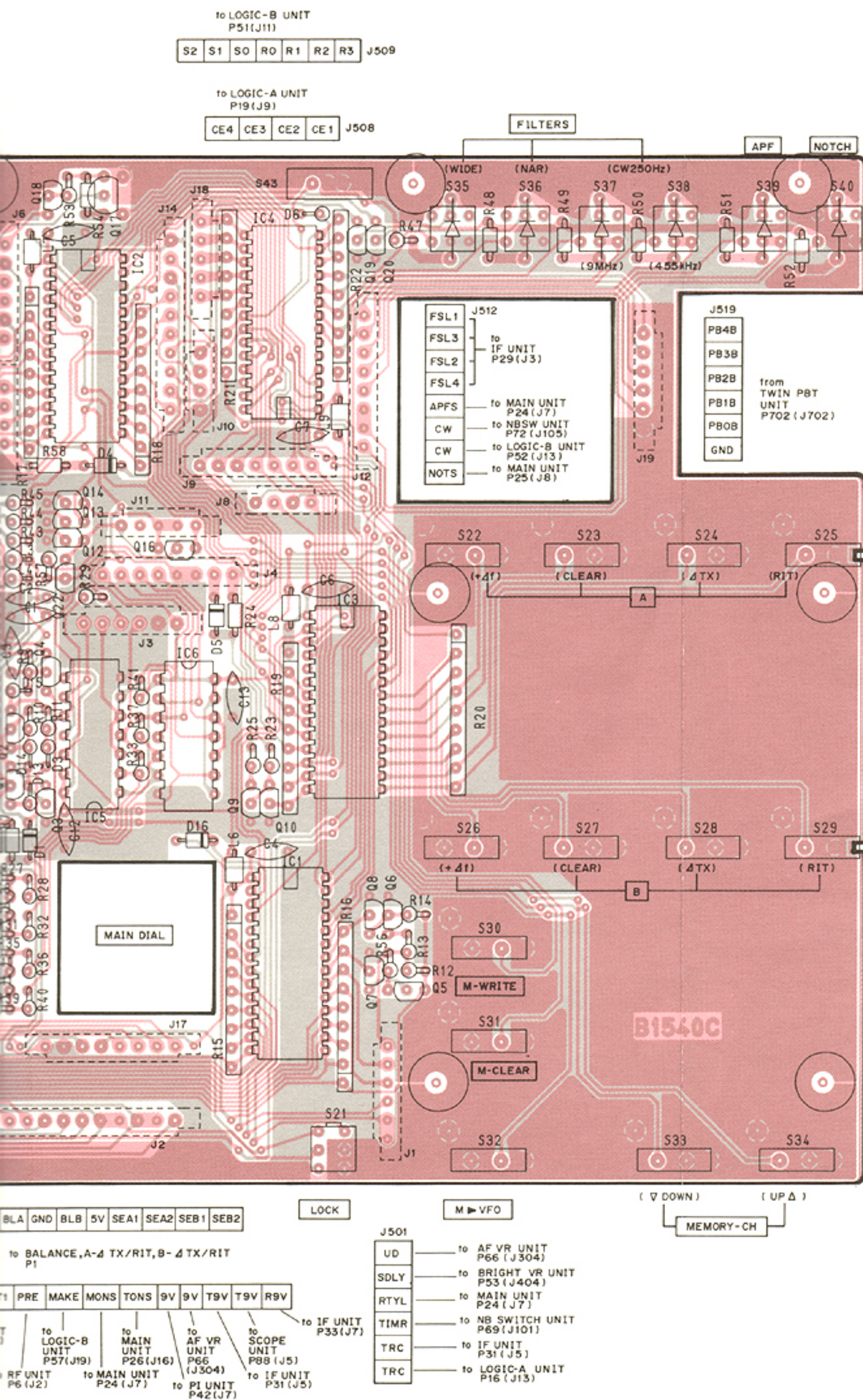

2SA1048 Y  
Q505



2SB562 C  
Q517



2SC2458 Y  
Q502, Q506

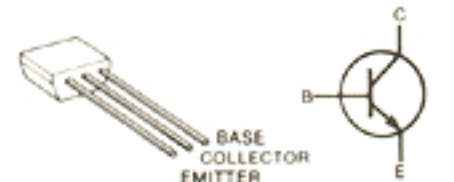

RN1202  
Q503, Q513

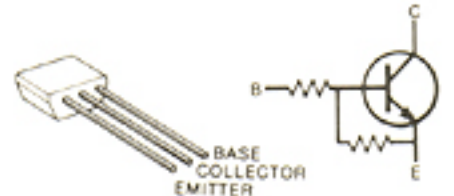

RN1204  
Q507, Q508  
Q509, Q510  
Q511, Q512  
Q514, Q515  
Q516, Q518  
Q519, Q520  
Q522

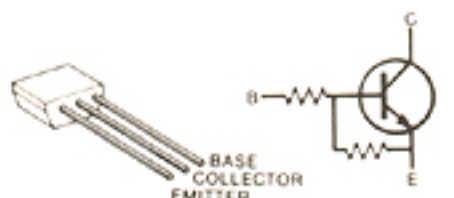

RN2202  
Q501, Q504

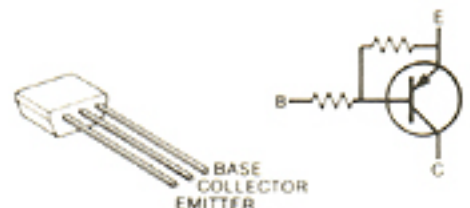

FOIL SIDE  
COMPONENT SIDE



# 7-4 MAIN AND IDC UNITS

## • IDC UNIT

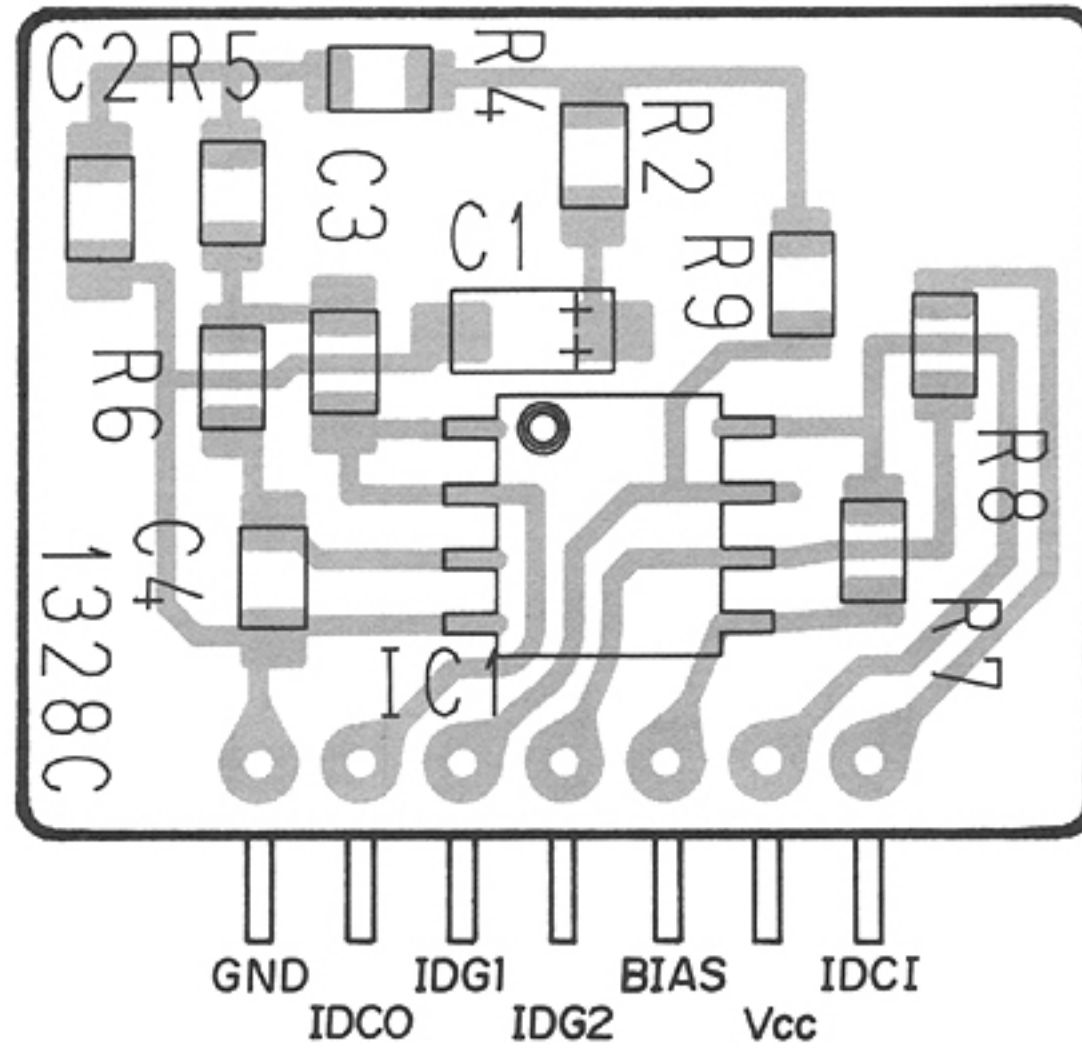

## • MAIN UNIT

**2SA1048 GR**  
Q53, Q54  
Q55



**2SC2458 GR**  
Q36, Q37

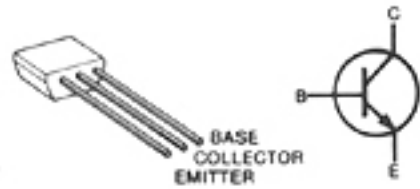

**2SC2668 O**  
Q3, Q8  
Q20, Q26  
Q27

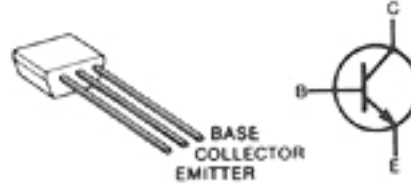

**2SC2785 EF**  
Q1, Q4, Q5  
Q9, Q10  
Q15, Q16  
Q18, Q22  
Q23, Q24  
Q29, Q31  
Q34, Q43  
Q46, Q56  
Q63

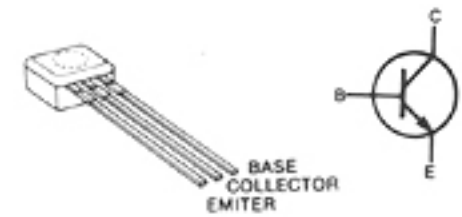

**2SC2878**  
Q61

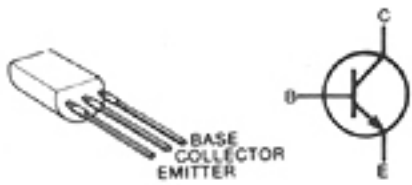

**2SJ105 GR**  
Q30, Q35  
Q38, Q40  
Q60, Q64

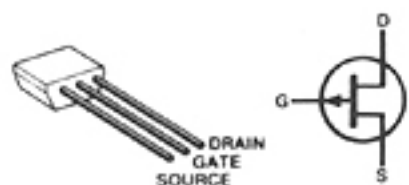

**2SK192A GR**  
Q2, Q7  
Q19

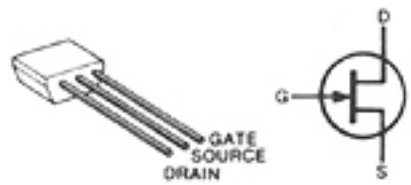

**2SK241 Y**  
Q6, Q11  
Q14

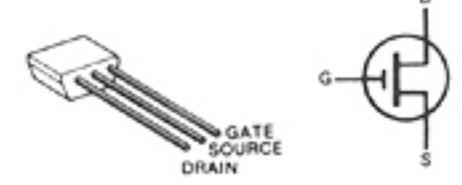

**3SK74 M**  
Q44, Q45

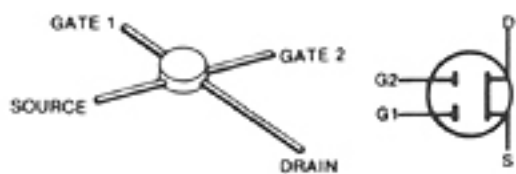

**RN1202**  
Q28

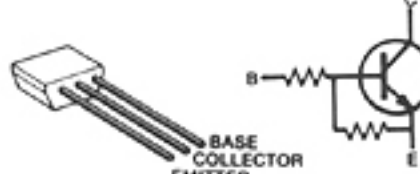

**RN1204**  
Q12, Q13  
Q17, Q32  
Q33, Q39  
Q41, Q42  
Q47, Q48  
Q52, Q57  
Q58, Q59

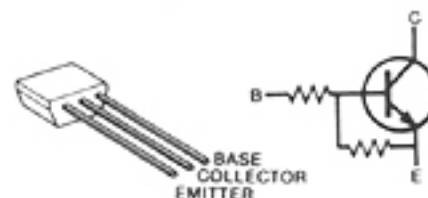

**RN2202**  
Q50, Q51  
Q62

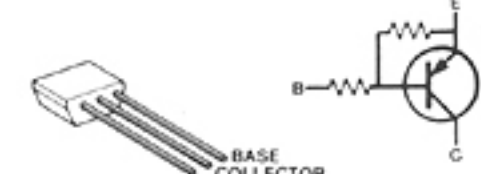

**RN2204**  
Q25, Q49

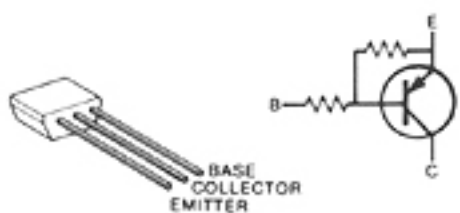

• MAIN UNIT

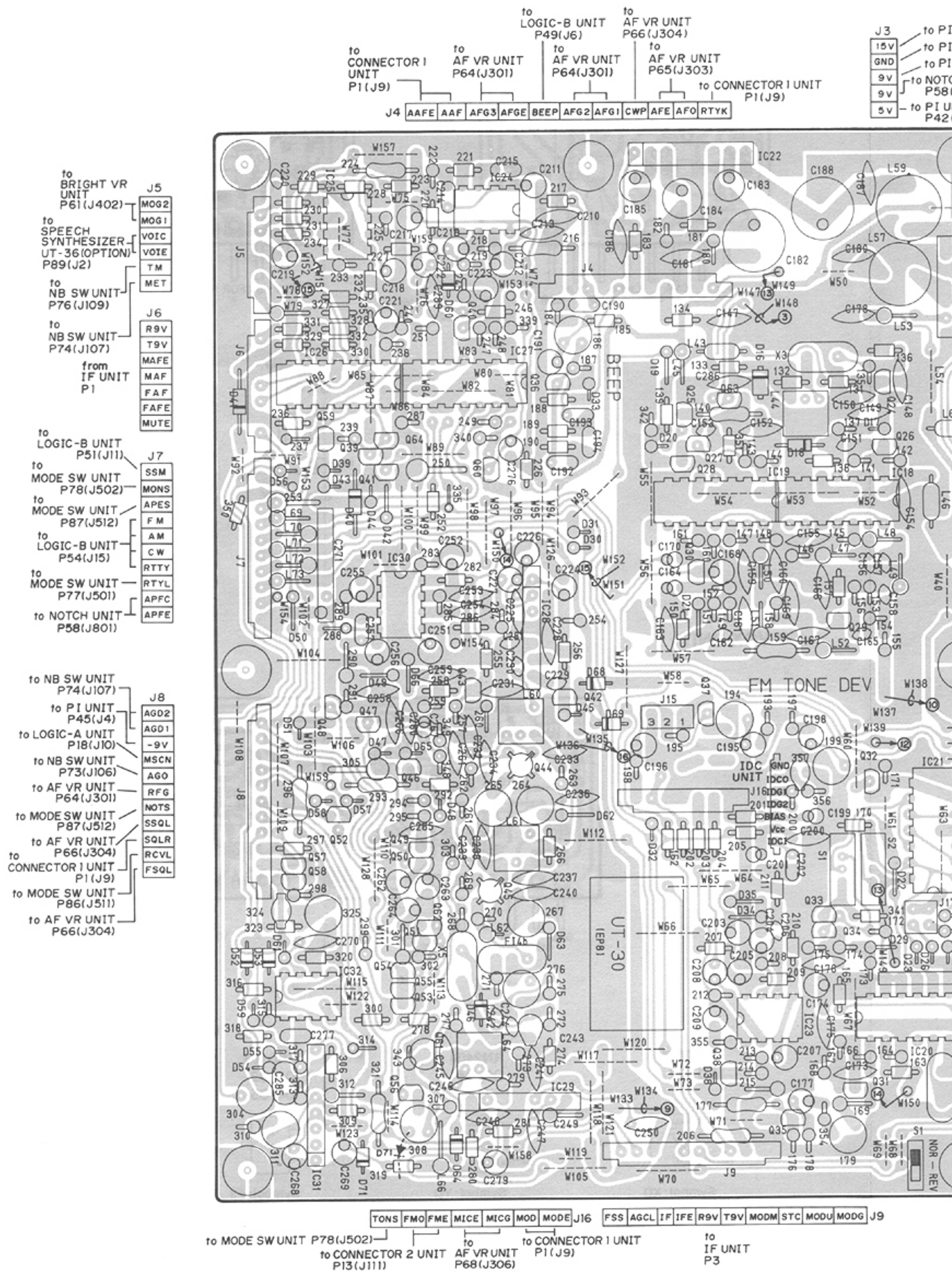



NIT

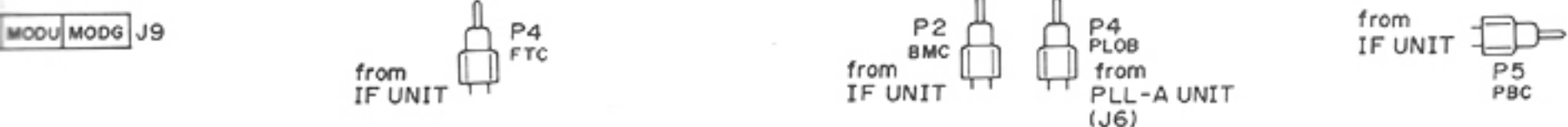
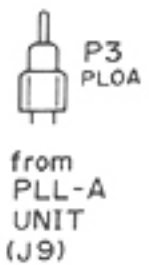
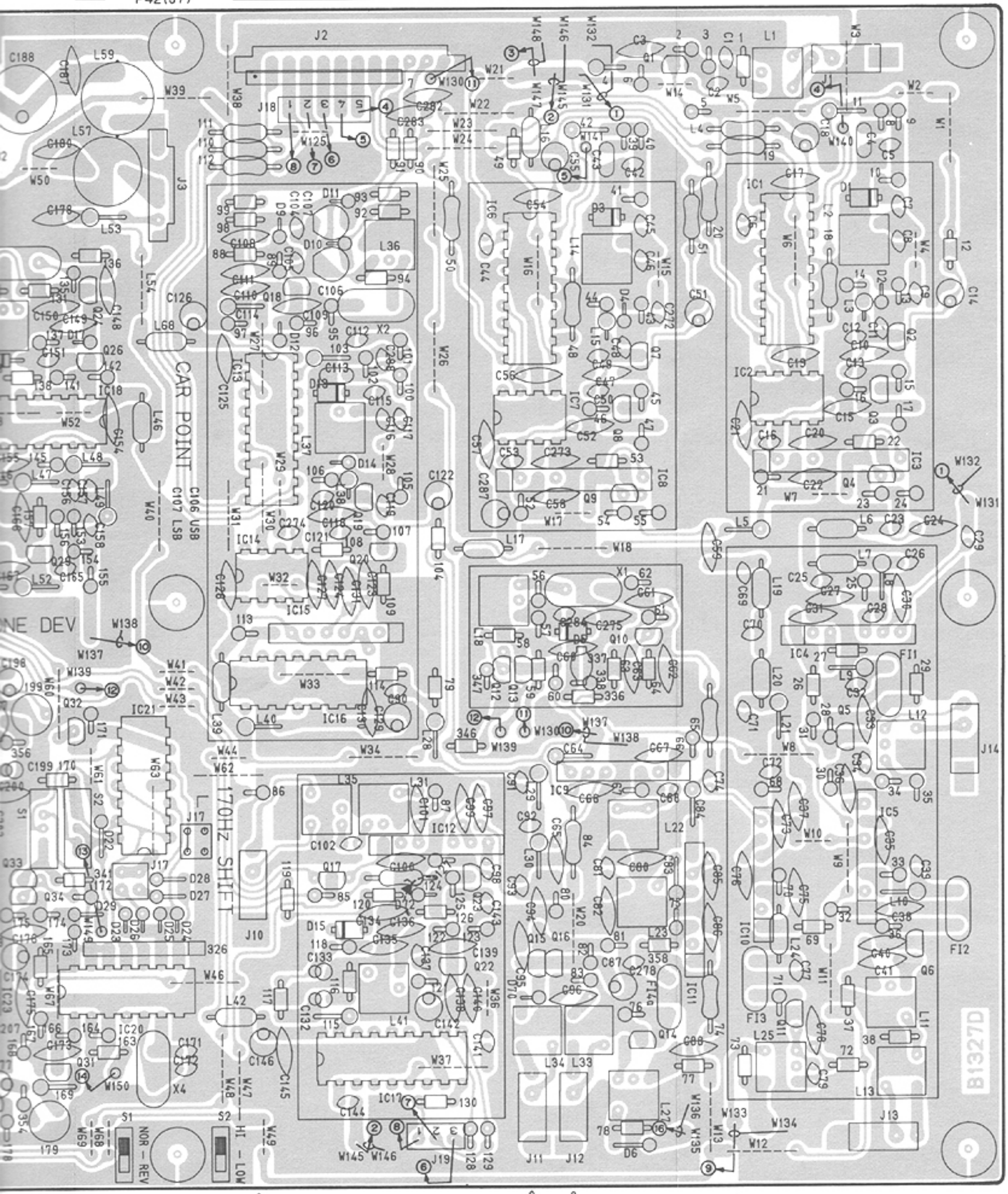
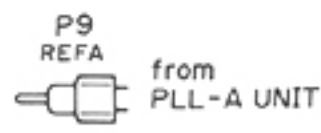
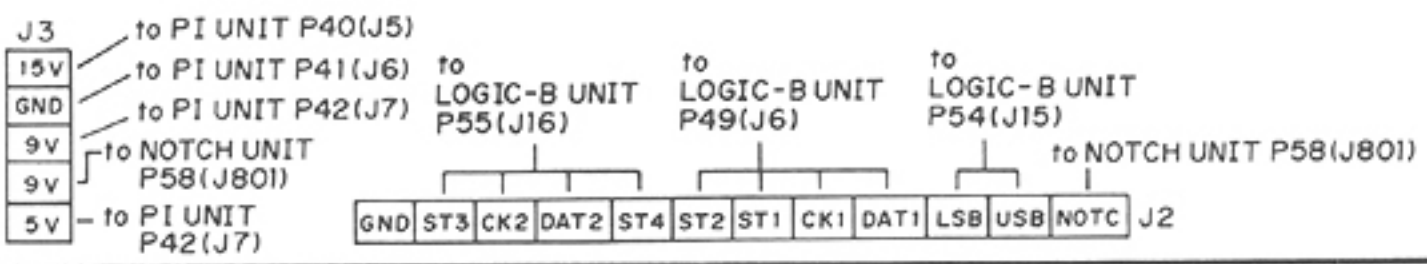

# 7-5 IF, VOX, CM AND SWR UNITS

## • CM UNIT

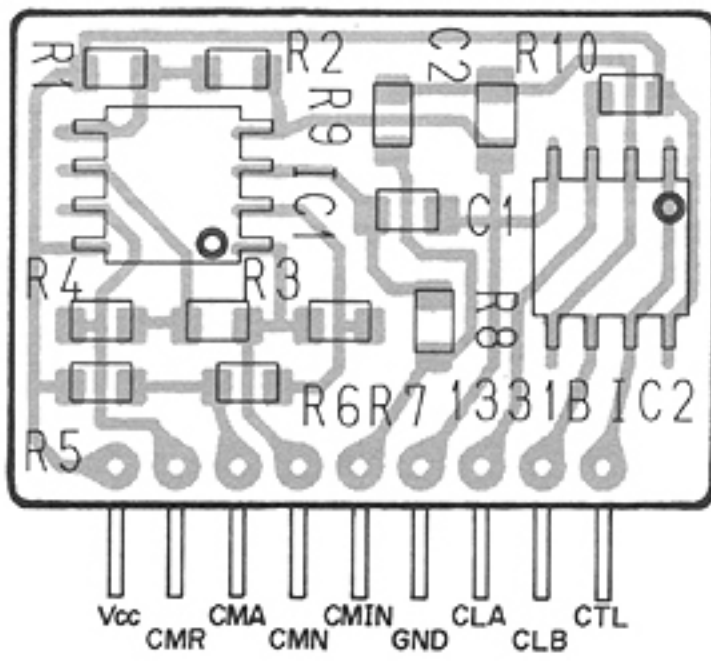

## • SWR UNIT

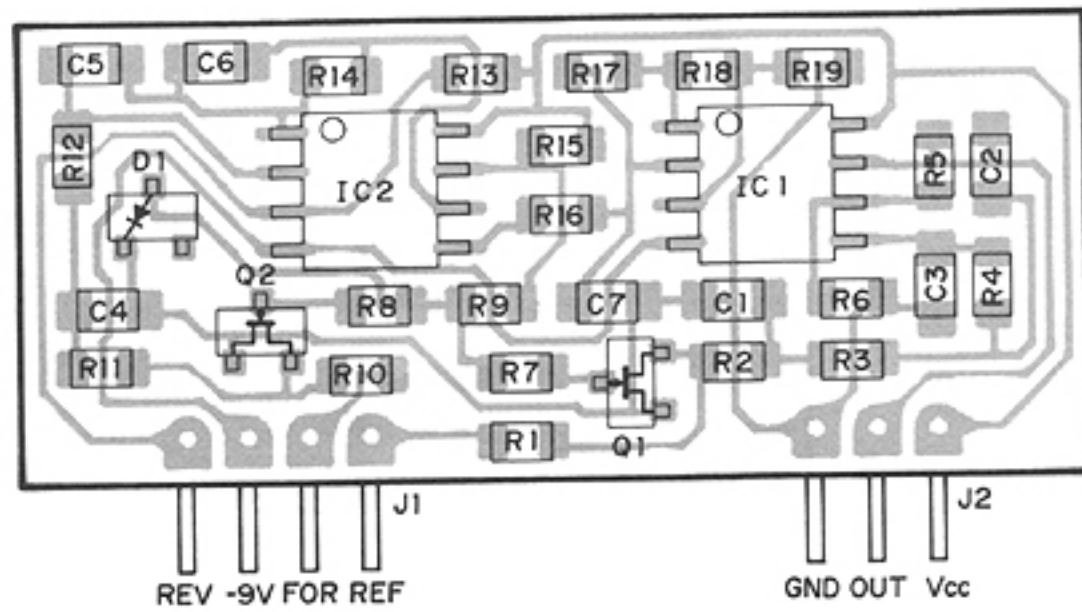

**2SK209 Y**  
Q1, Q2



Symbol: XY

**1SS187**  
D1

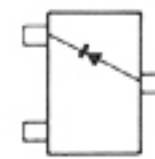

Symbol: D3

## • VOX UNIT

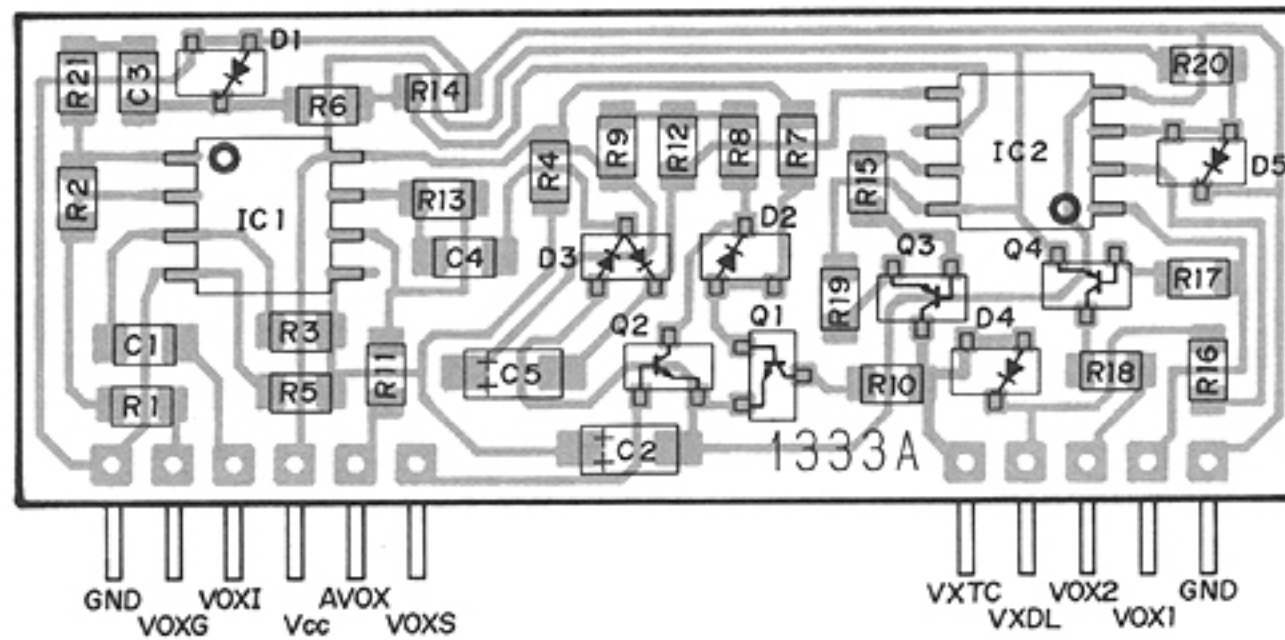

**RN1404**  
Q1, Q2

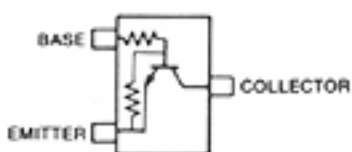

Symbol: XD

**RN2404**  
Q3, Q4

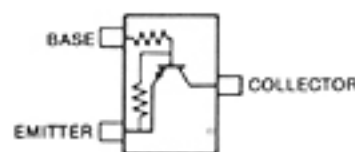

Symbol: YD

**1SS193**  
D1, D2  
D4, D5

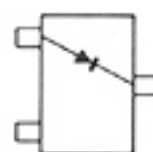

Symbol: F3

**1SS226**  
D3

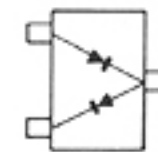

Symbol: C3







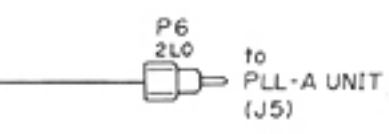
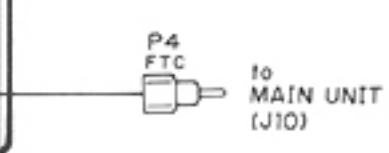
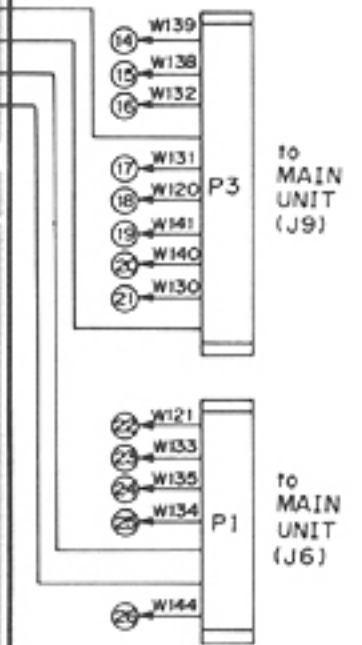
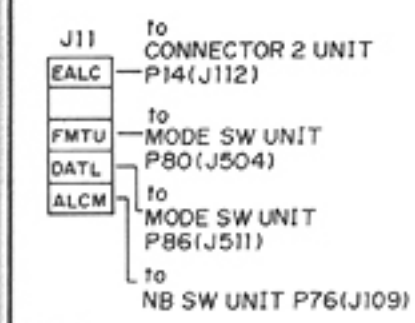
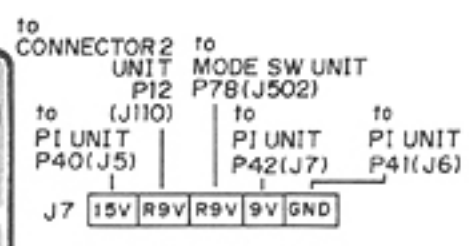
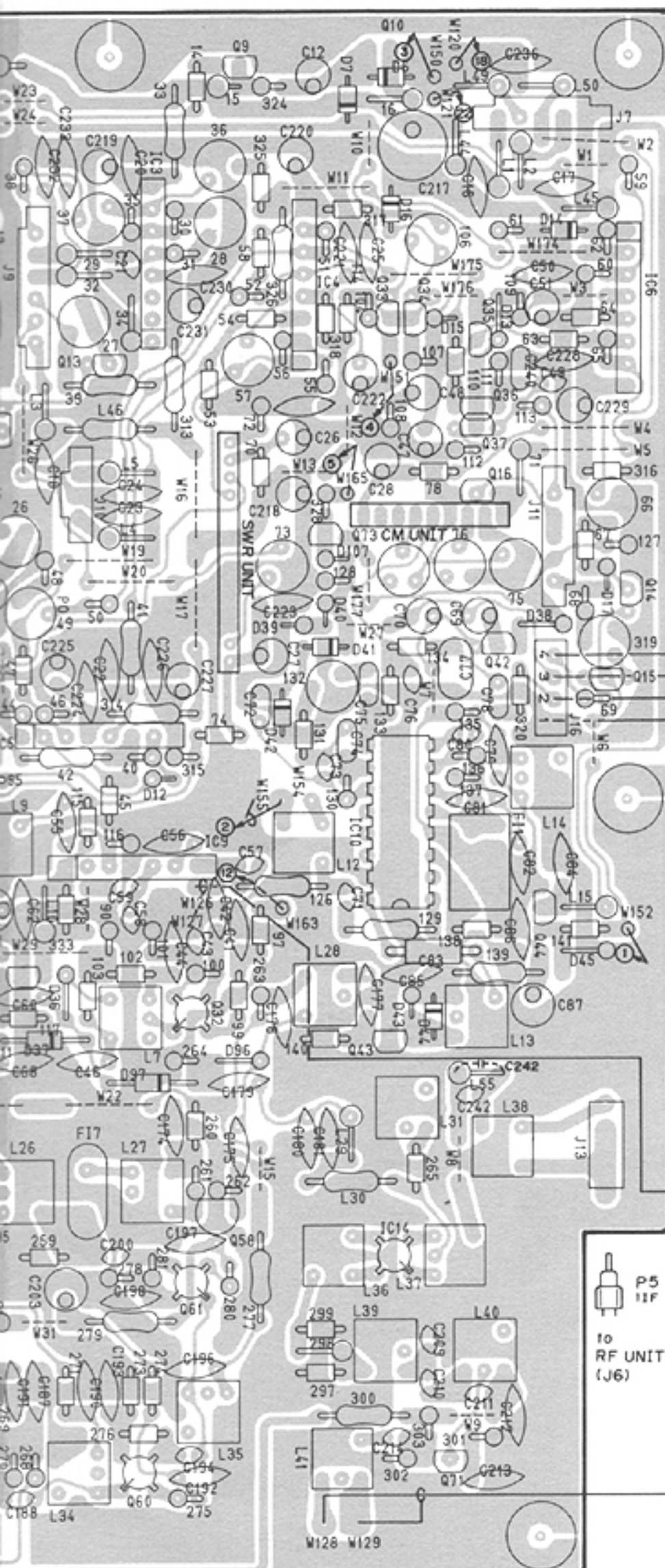
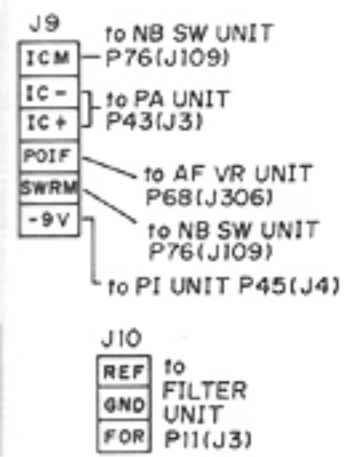

**2SA1048 GR**  
 Q33, Q34  
 Q36, Q37  
 Q48, Q64  
 Q66, Q67

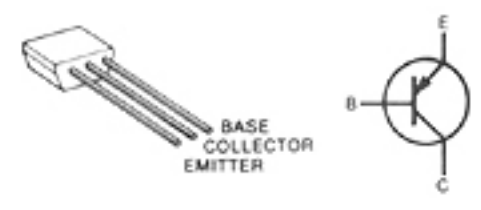

**2SK241 Y**  
 Q38, Q43  
 Q46

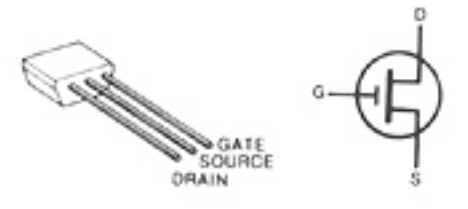

**2SC2458 GR**  
 Q4, Q22  
 Q23, Q24  
 Q30, Q31  
 Q40, Q49  
 Q55, Q62  
 Q63, Q65  
 Q68, Q69  
 Q72

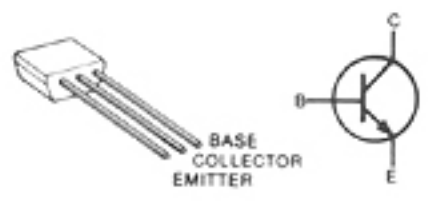

**3SK74 M**  
 Q32, Q39  
 Q51, Q56

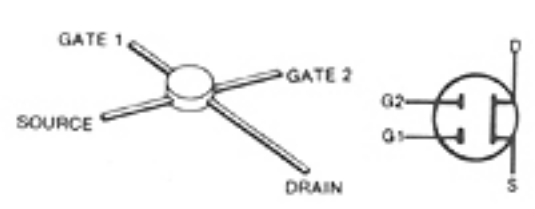

**2SC2668 O**  
 Q71

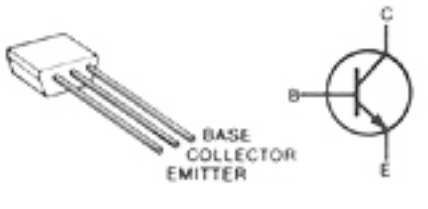

**RN1202**  
 Q8, Q52  
 Q70, Q73

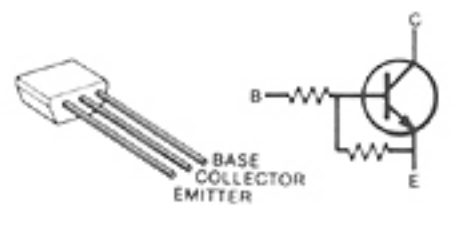

**2SC2785 FF**  
 Q6, Q9  
 Q11, Q15  
 Q44, Q47  
 Q50, Q53  
 Q74

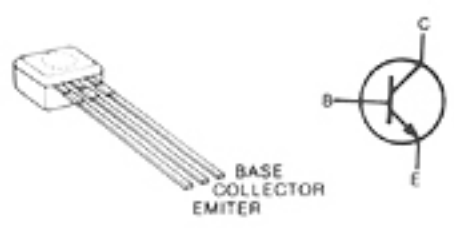

**RN1204**  
 Q1, Q2  
 Q5, Q7  
 Q13, Q14  
 Q16, Q17  
 Q18, Q19  
 Q21, Q25  
 Q26, Q27  
 Q28, Q29  
 Q35, Q41  
 Q45, Q54

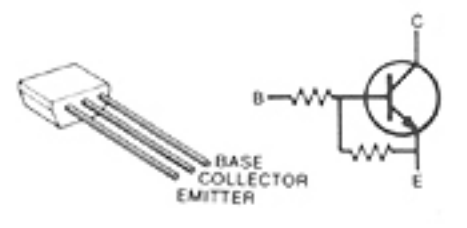

**2SD468 C**  
 Q3

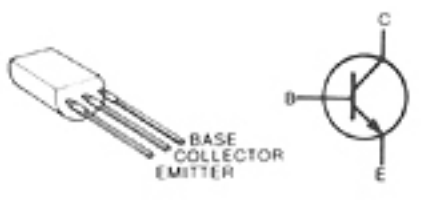

**RN2202**  
 Q20

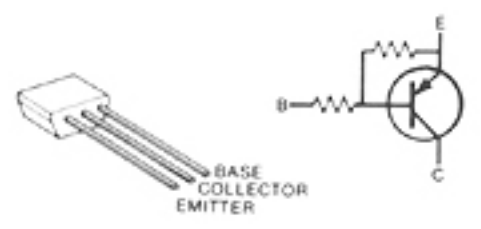

**2SD880 Y**  
 Q10, Q12

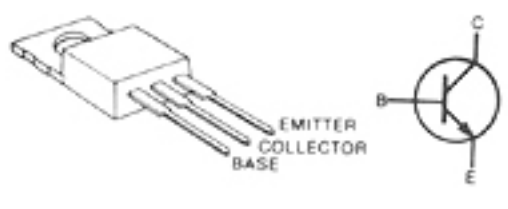

**RN2204**  
 Q42

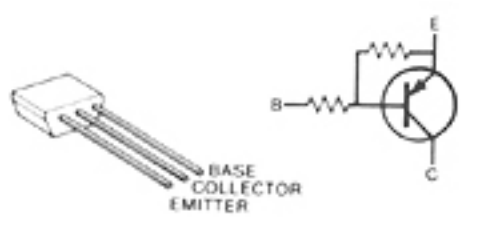

**2SK125**  
 Q58

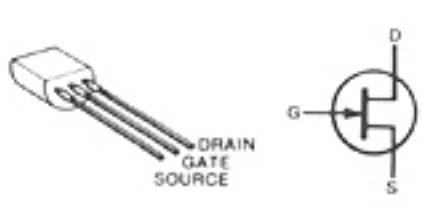

# 7-6 RF UNIT

## • MIXER A

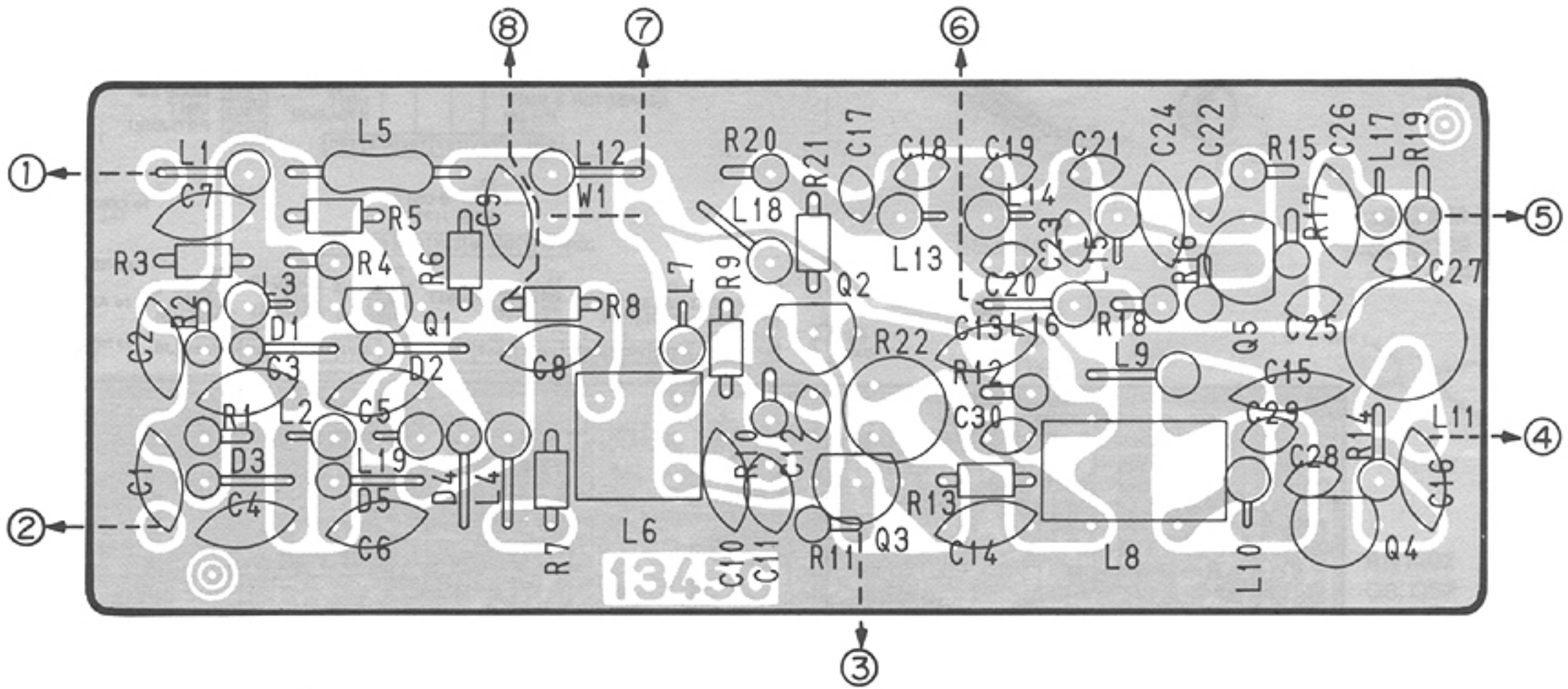

**2SA1048 Y**  
Q301

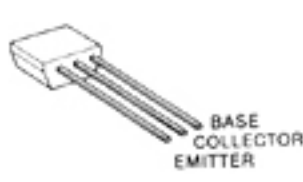

**2SC2053**  
Q305

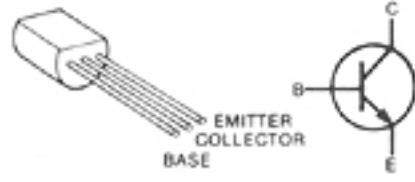

**2SK125**  
Q302, Q303  
Q304

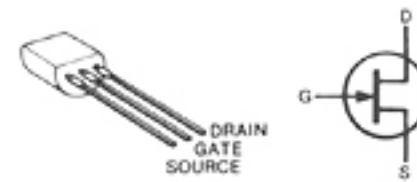

**NOTE:** Add "300" to the indicated number on the unit for actual part number respectively.

## • MIXER B

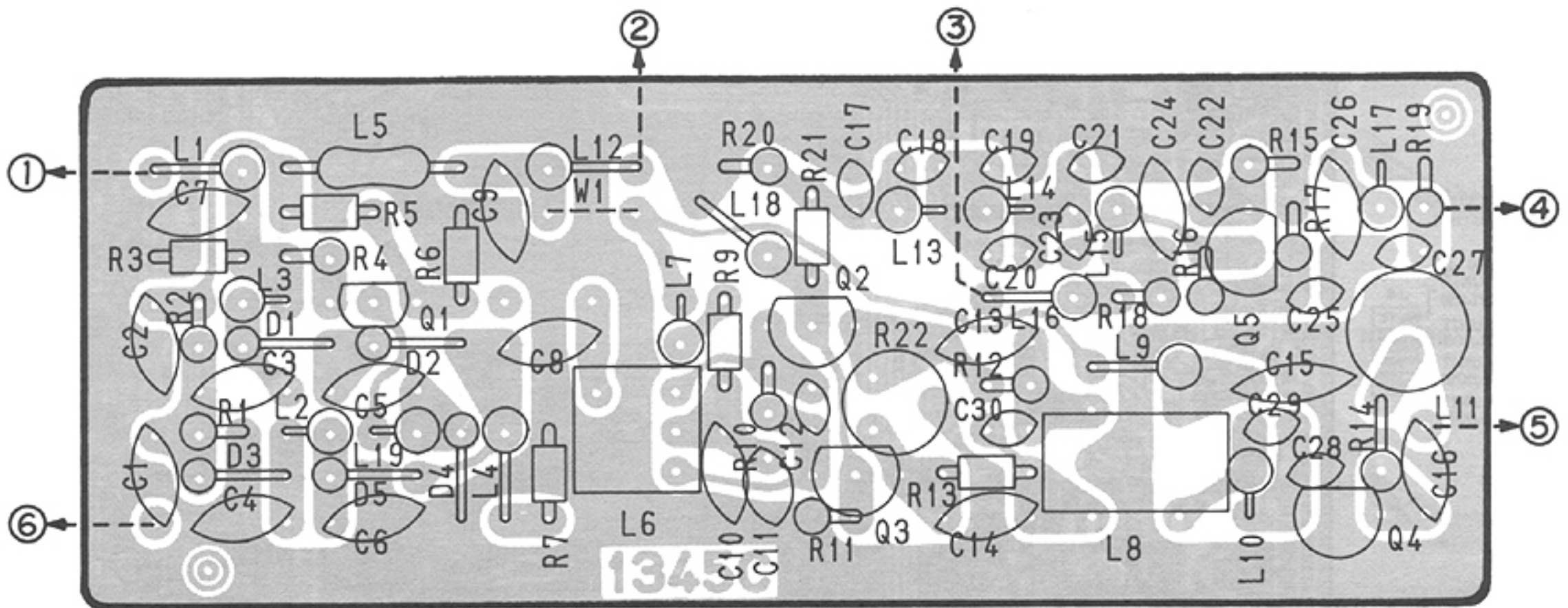

**2SA1048 Y**  
Q401



**2SC2053**  
Q405

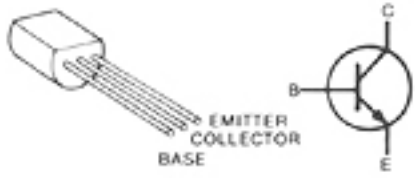

**2SK125**  
Q402, Q403  
Q404

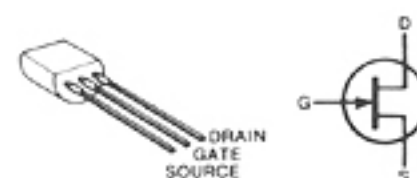

**NOTE:** Add "400" to the indicated number on the unit for actual part number respectively.



• RF UNIT

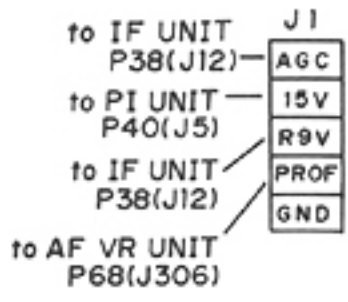
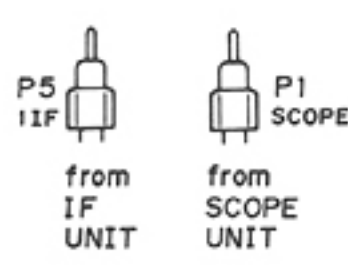
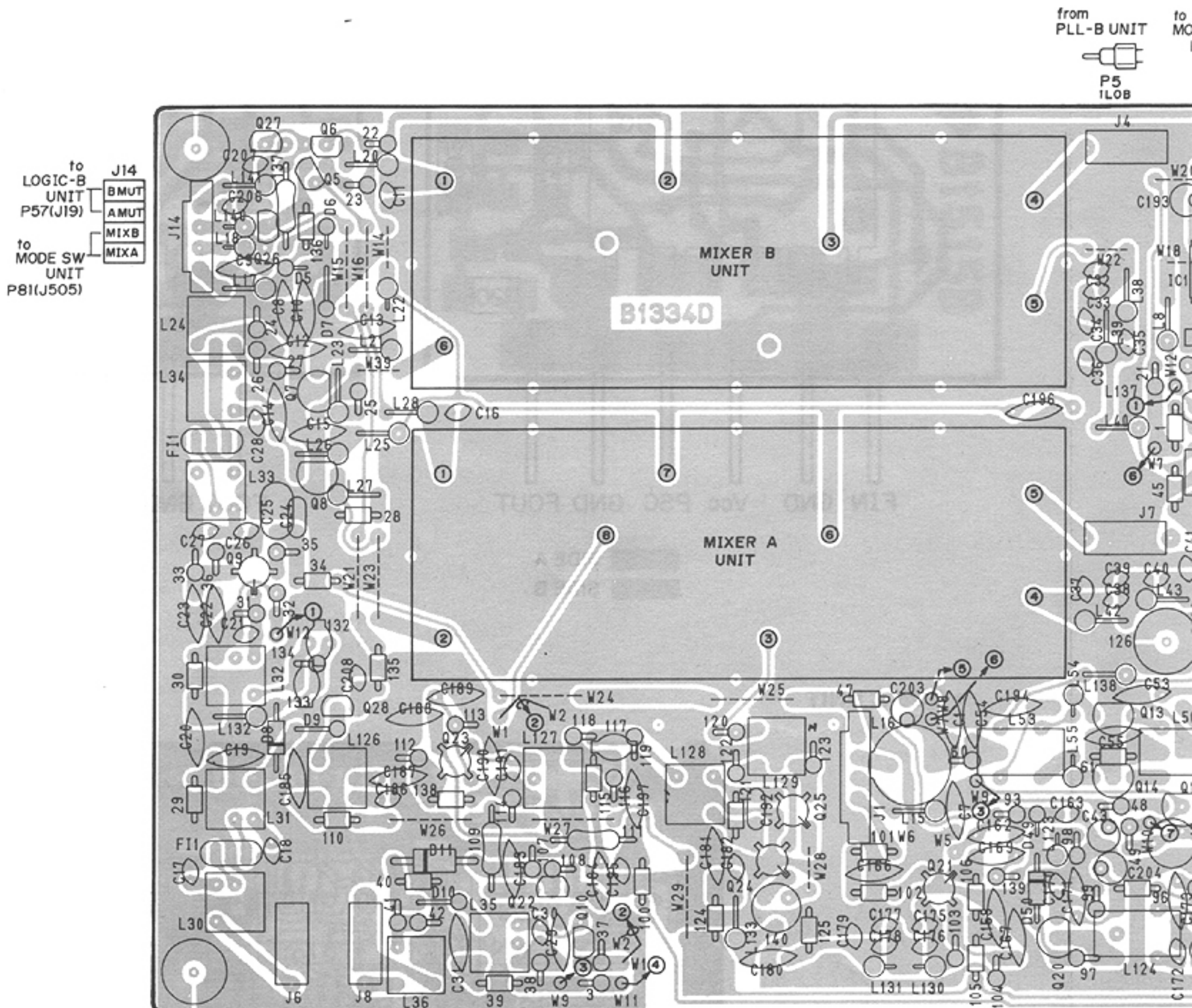

**2SA1048 Y**  
Q11, Q16



**2SB562 C**  
Q1

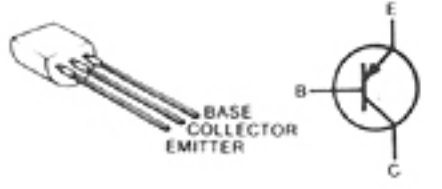

**2SC1571 G**  
Q12

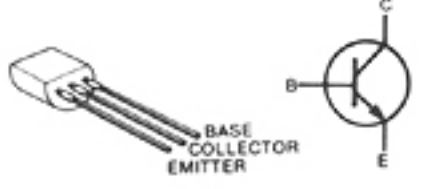

**2SC2053**  
Q20

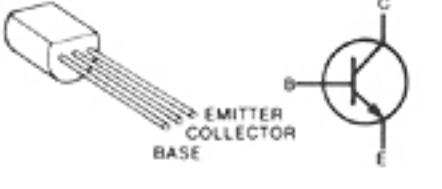

**2SC2458 GR**  
Q5, Q6

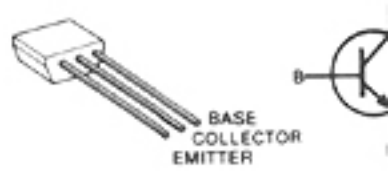

**RN1204**  
Q3, Q17  
Q26, Q27

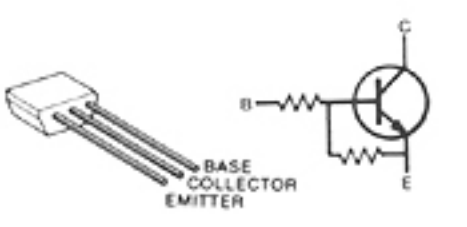

**RN2202**  
Q19

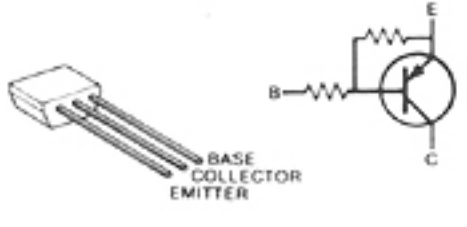

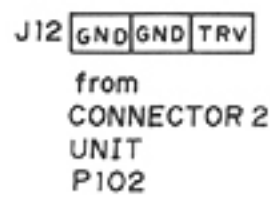
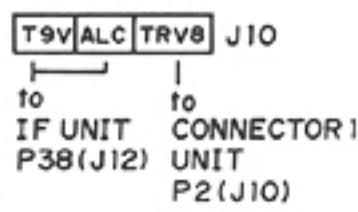
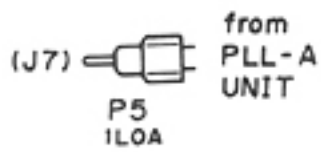
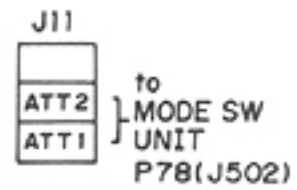
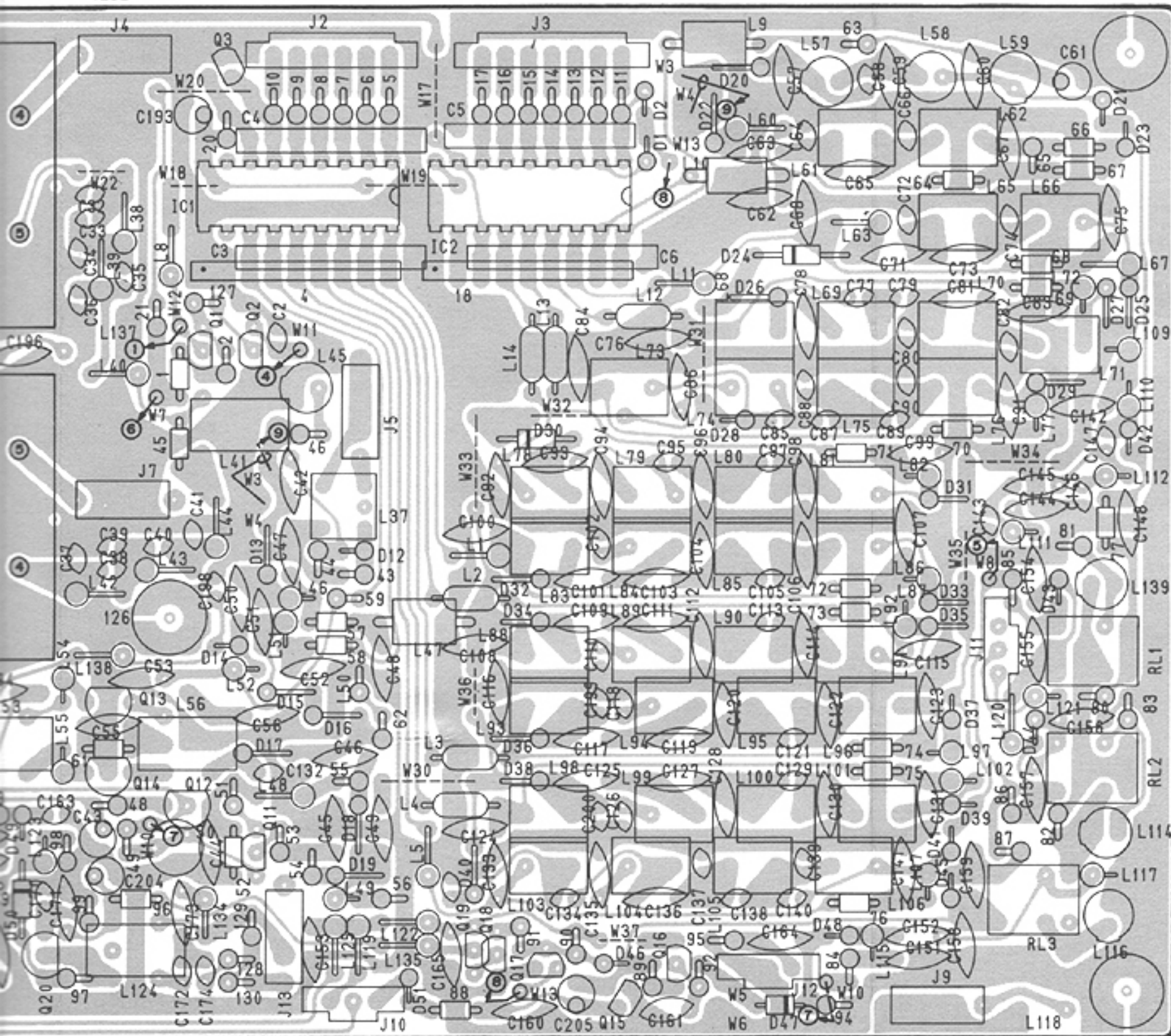
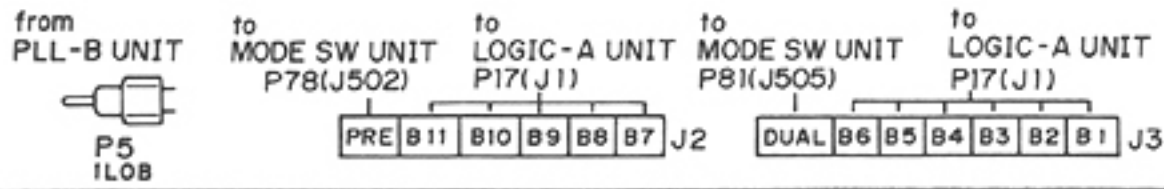
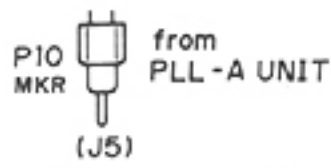

2SC2458 GR  
Q5, Q6

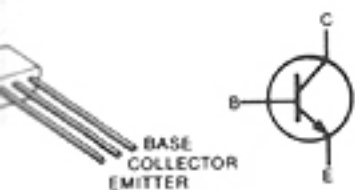

3SK74 M/K  
Q9, Q21  
Q23, Q24  
Q25

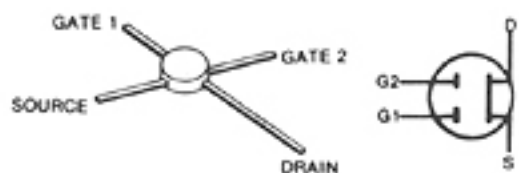

2SK125  
Q7, Q8  
Q13, Q14

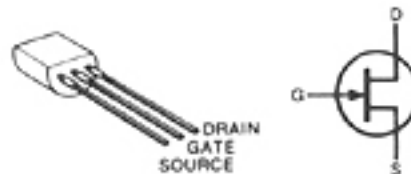

2SK241 Y  
Q10, Q22

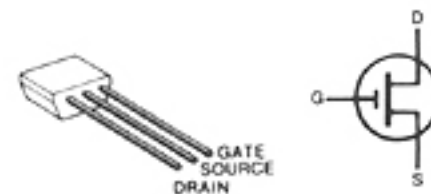

RN1202  
Q2, Q15  
Q18

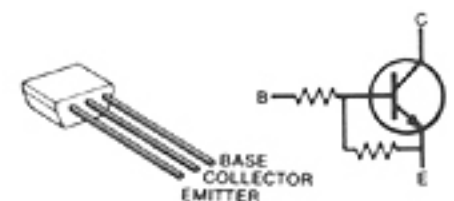



## 7-7 PLL-A AND DDS-A UNITS

### • EP2

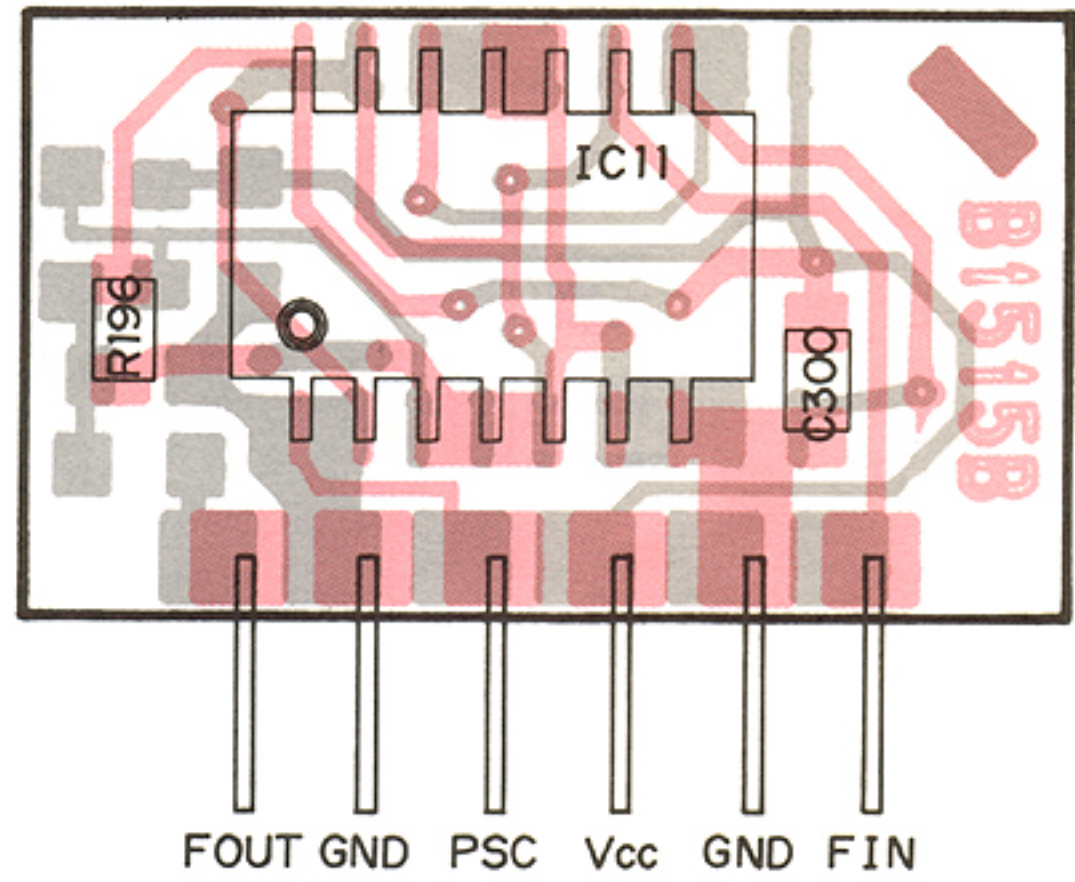
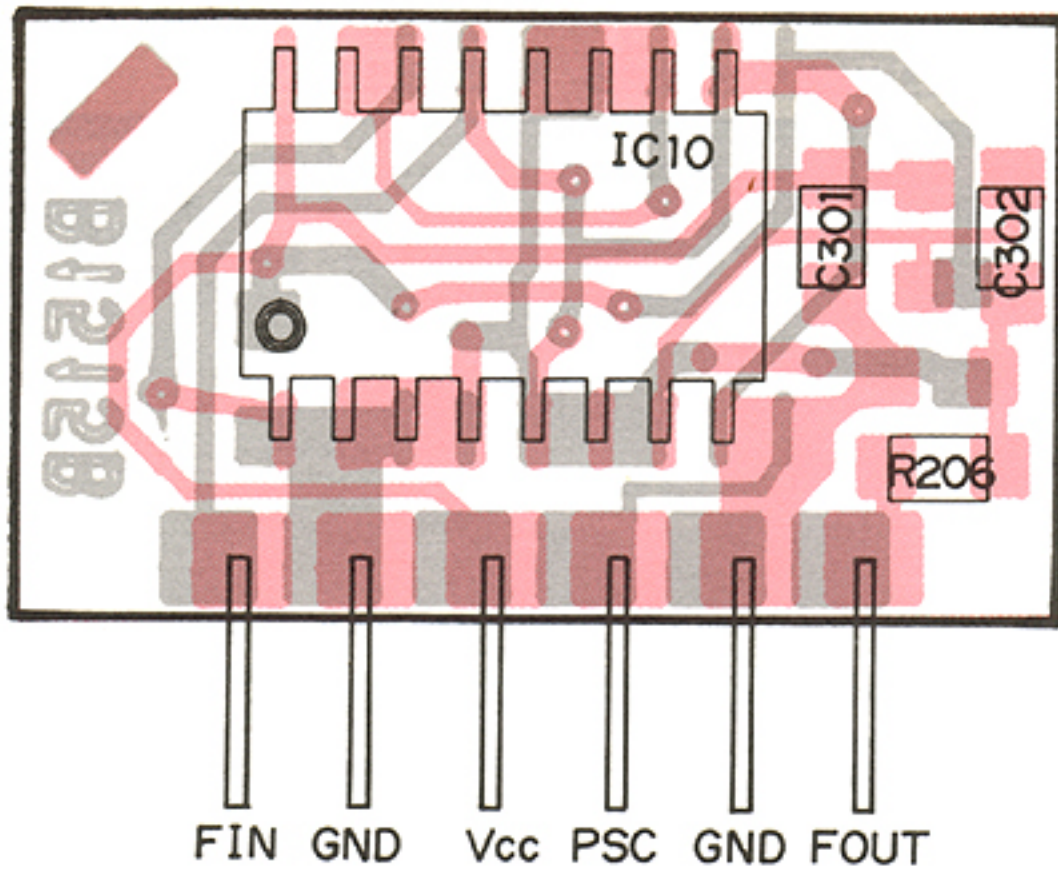

SIDE A  
 SIDE B

SIDE A  
 SIDE B

### • DDS-A UNIT

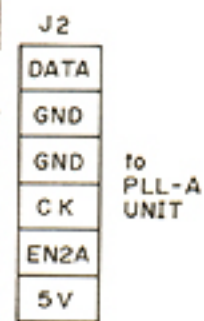
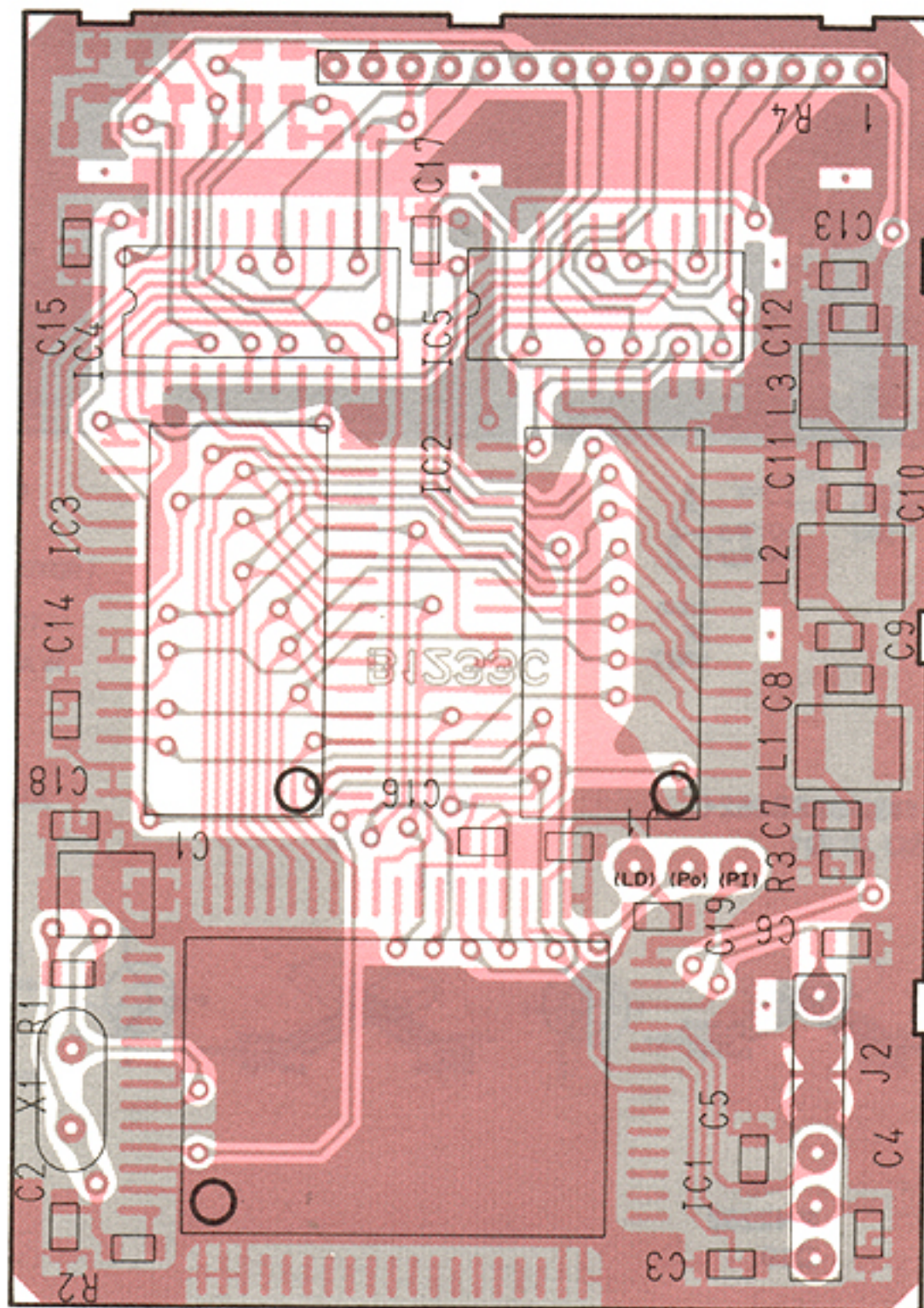

FOIL SIDE  
 COMPONENT SIDE



• PLL-A UNIT

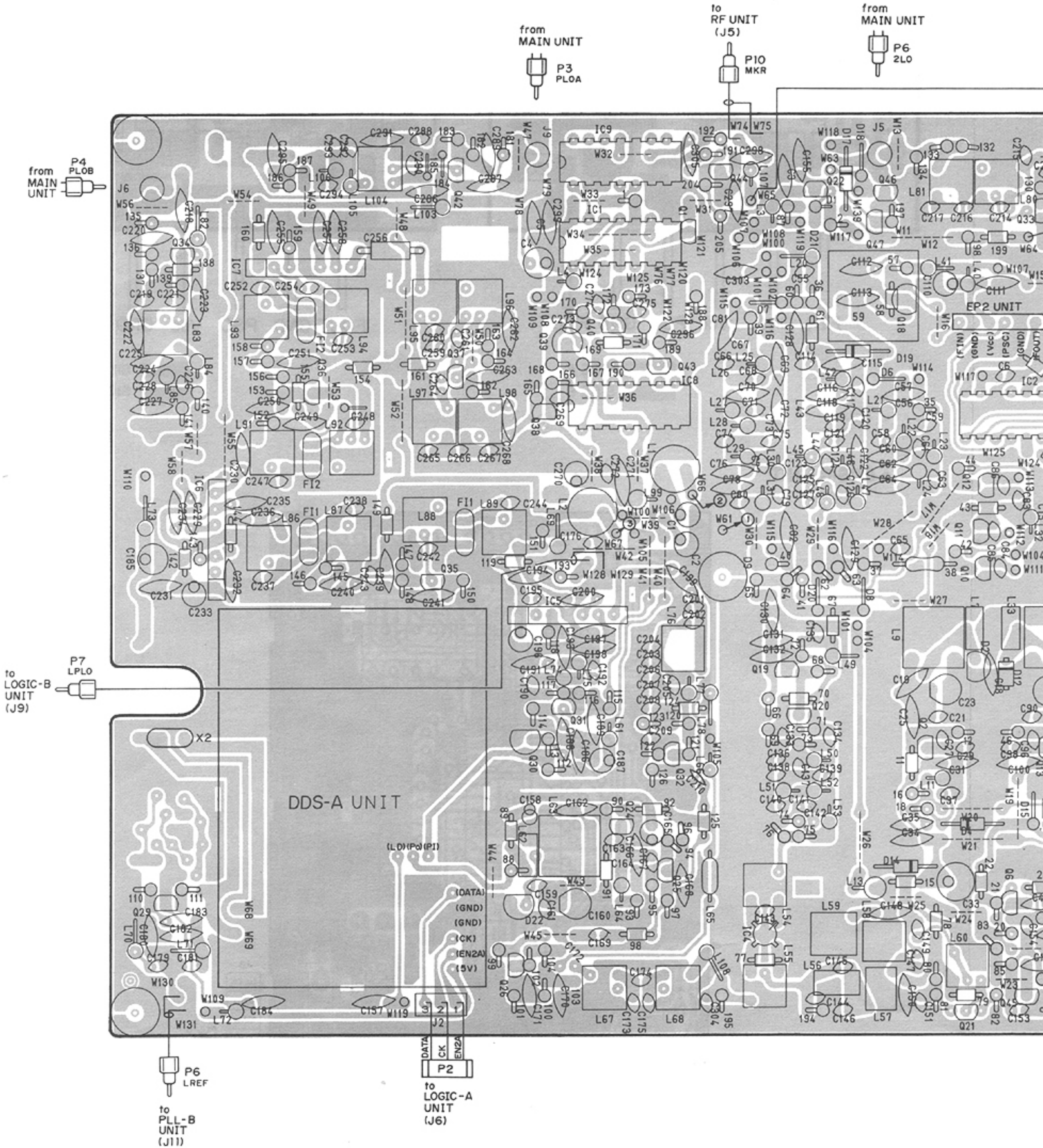



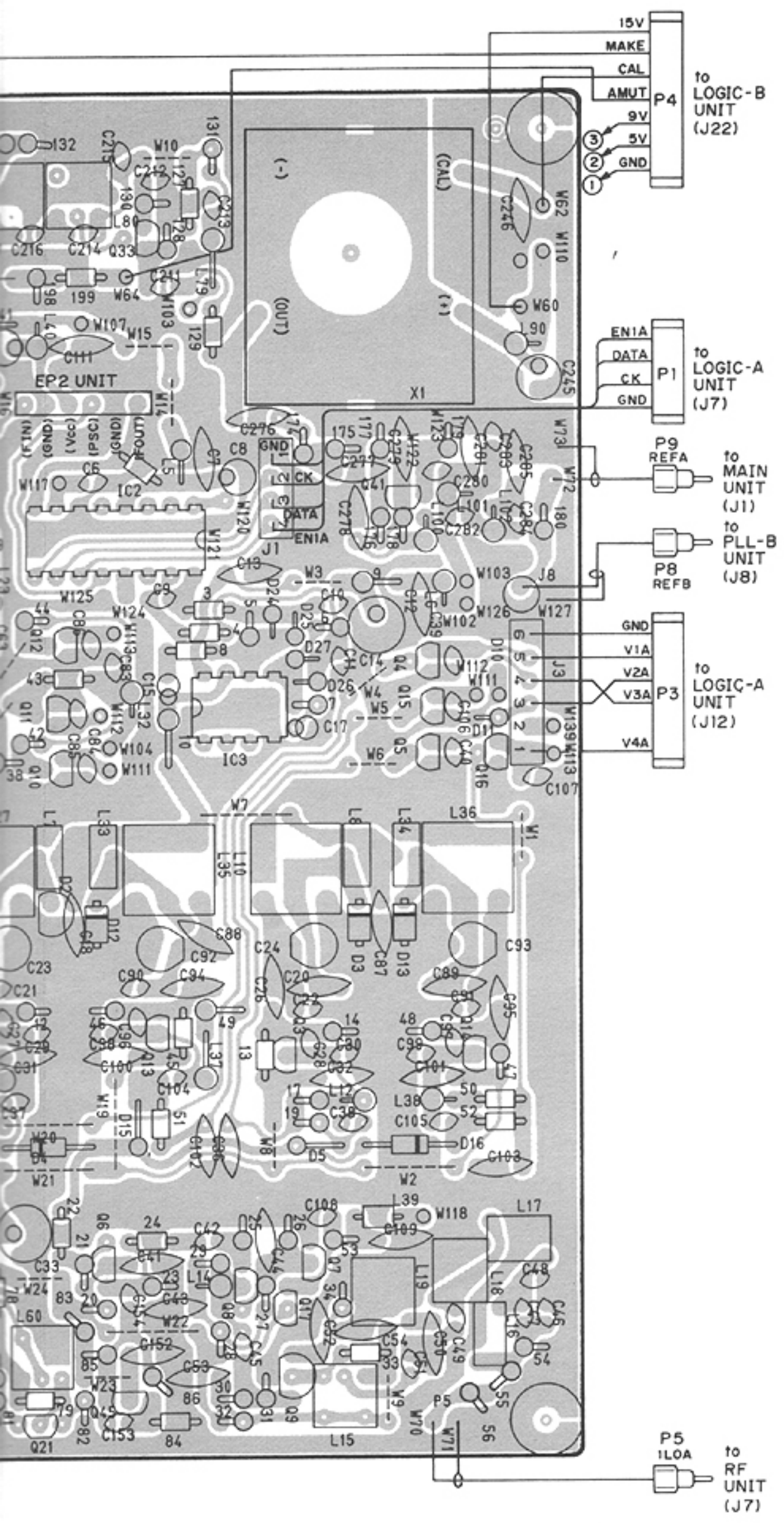

**2SC383TM**  
Q9

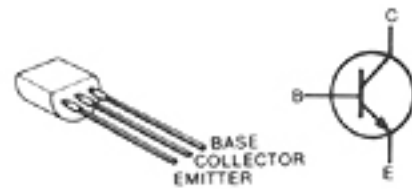

**RN1202**  
Q4, Q5  
Q10, Q11  
Q12, Q15  
Q16

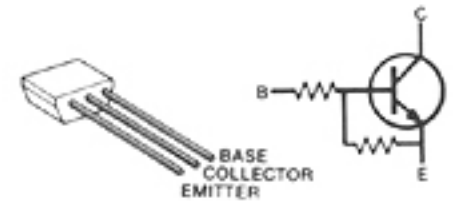

**2SC763 C**  
Q30, Q39

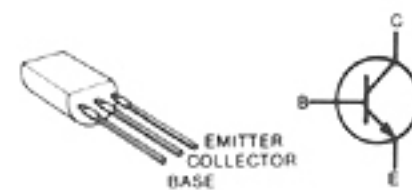

**RN1204**  
Q1

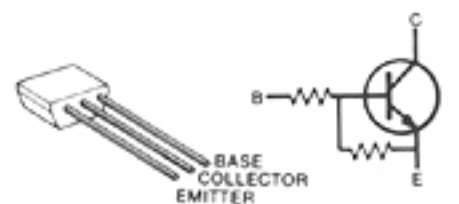

**2SC2026**  
Q18

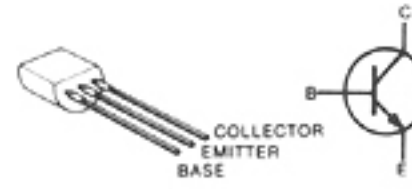

**RN2202**  
Q22

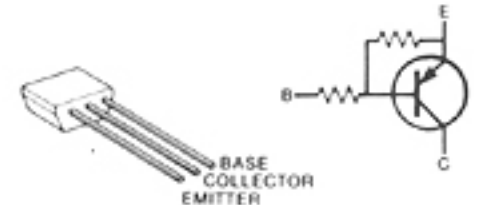

**2SC2668 O**  
Q6, Q8  
Q19, Q20  
Q21, Q25  
Q26, Q31  
Q32, Q35  
Q36, Q37  
Q40, Q45

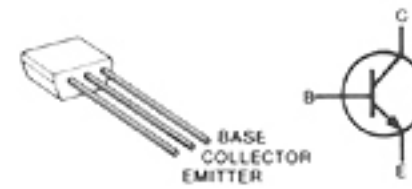

**2SC2785 EF**  
Q7, Q17  
Q29, Q33  
Q34, Q38  
Q41, Q42  
Q43, Q44

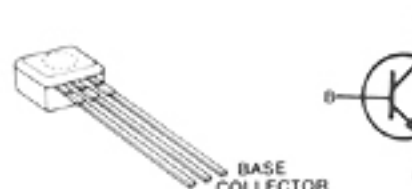

**2SK192A GR**  
Q2, Q3  
Q13, Q14  
Q24

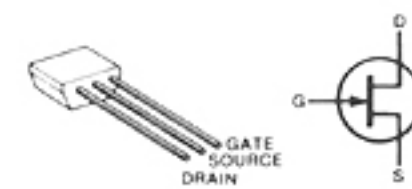



## 7-8 PLL-B AND DDS-B UNITS

### • EP2

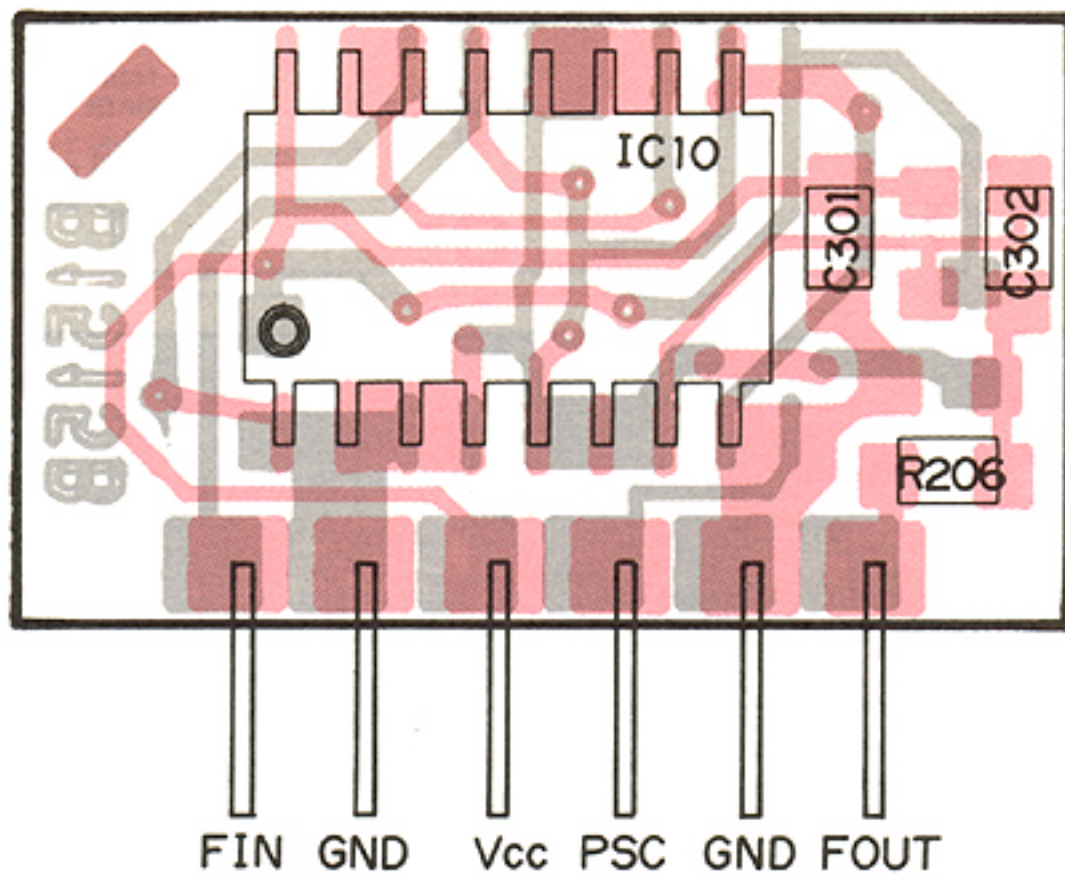

SIDE A  
 SIDE B

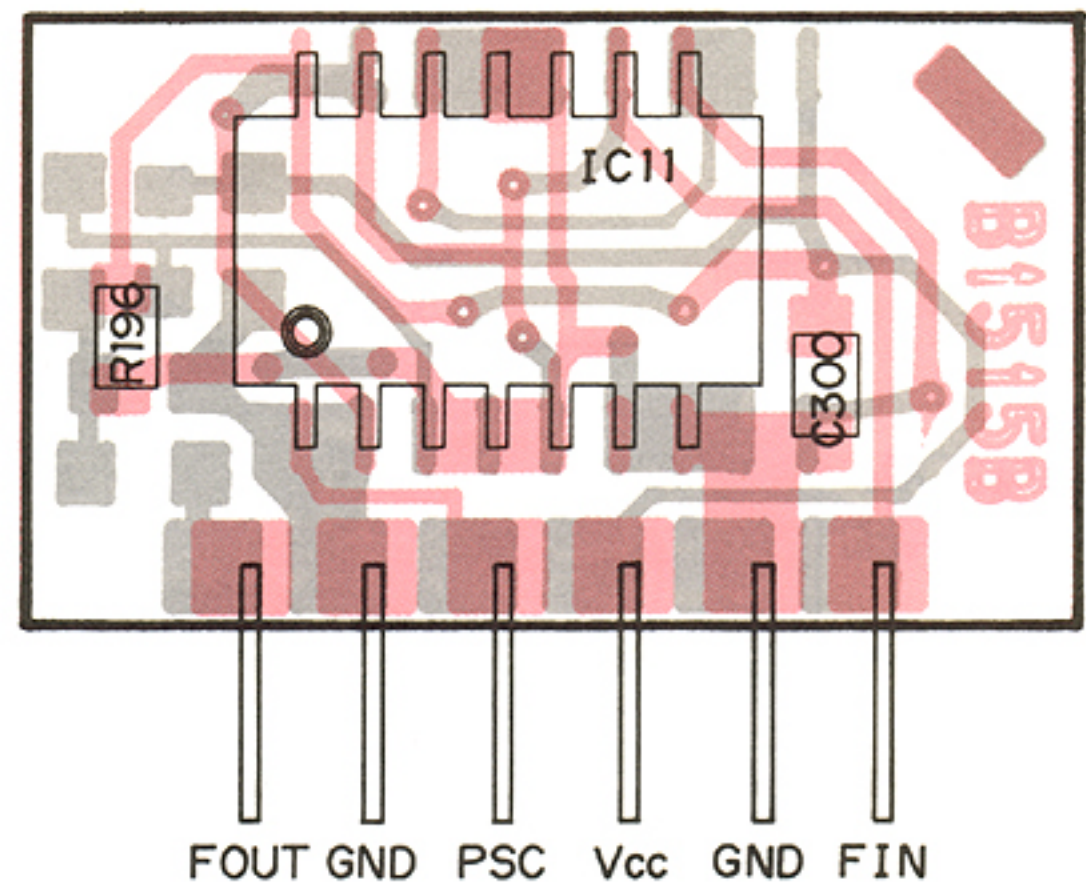

SIDE A  
 SIDE B

### • DDS-B UNIT

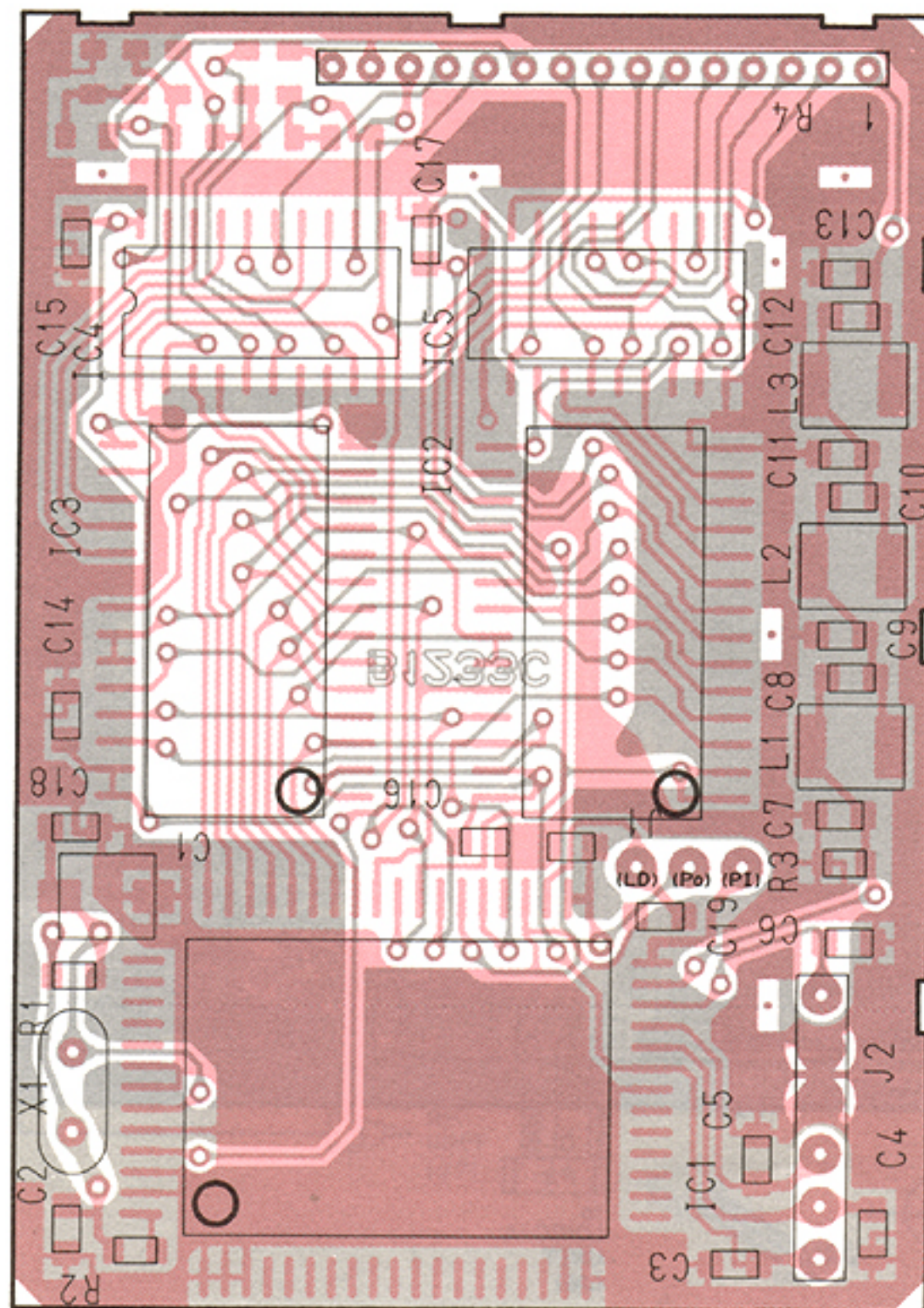

J2  
 DATA  
 GND  
 GND  
 CK  
 EN2A  
 5V  
 to  
 PLL-B  
 UNIT

FOIL SIDE  
 COMPONENT SIDE





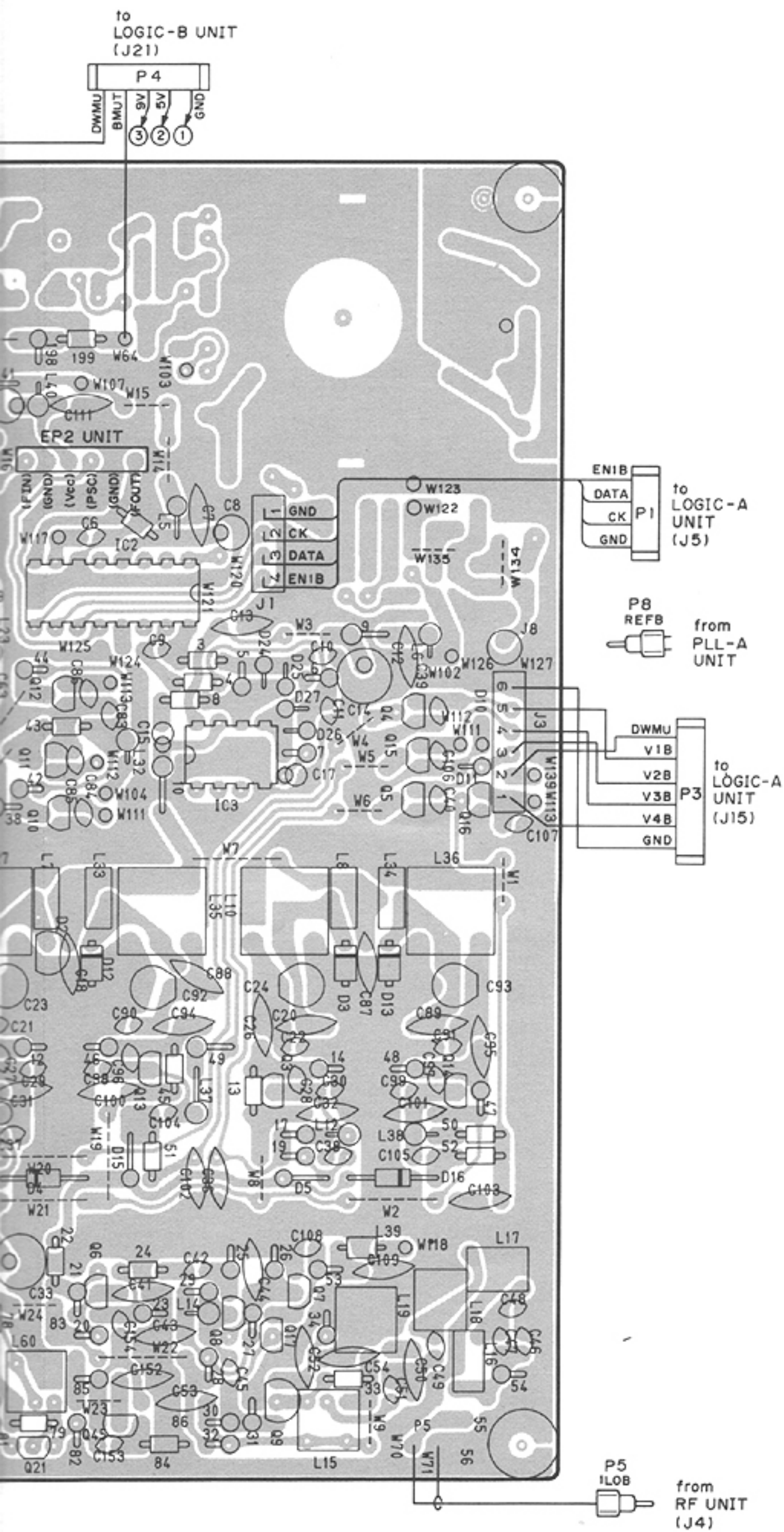

**2SC383TM**  
Q9

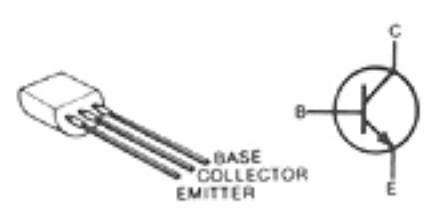

**RN1202**  
Q4, Q5  
Q10, Q11  
Q12, Q15  
Q16

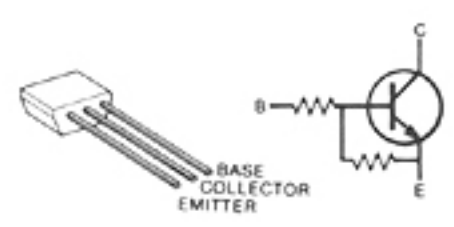

**2SC763 C**  
Q28, Q30  
Q39

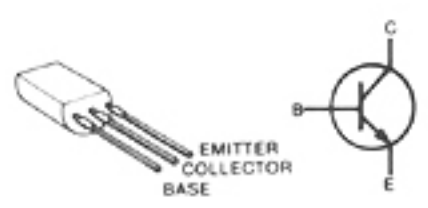

**RN1204**  
Q46

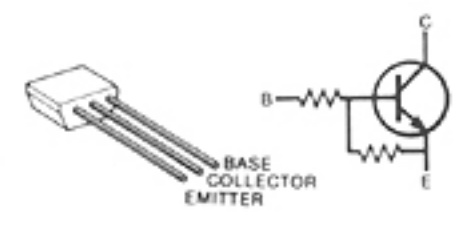

**2SC2026**  
Q18

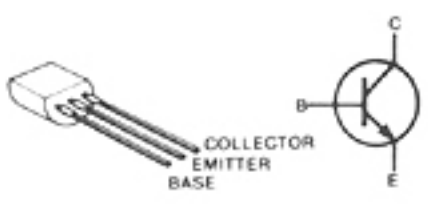

**RN2202**  
Q22

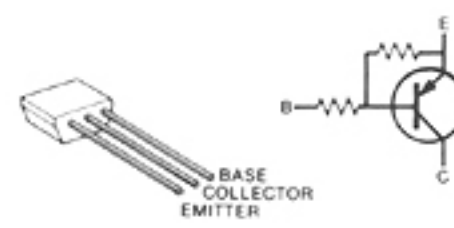

**2SC2668 O**  
Q6, Q8  
Q19, Q20  
Q21, Q25  
Q26, Q27  
Q31, Q32  
Q40, Q45

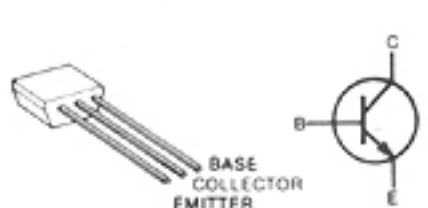

**2SC2785 EF**  
Q7, Q17  
Q42, Q43  
Q47



**2SK192A GR**  
Q2, Q3  
Q13, Q14  
Q24

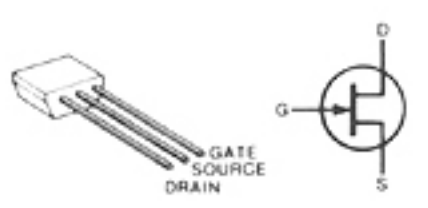



# 7-9 LOGIC-A AND CRTC UNITS

## • CRTC UNIT

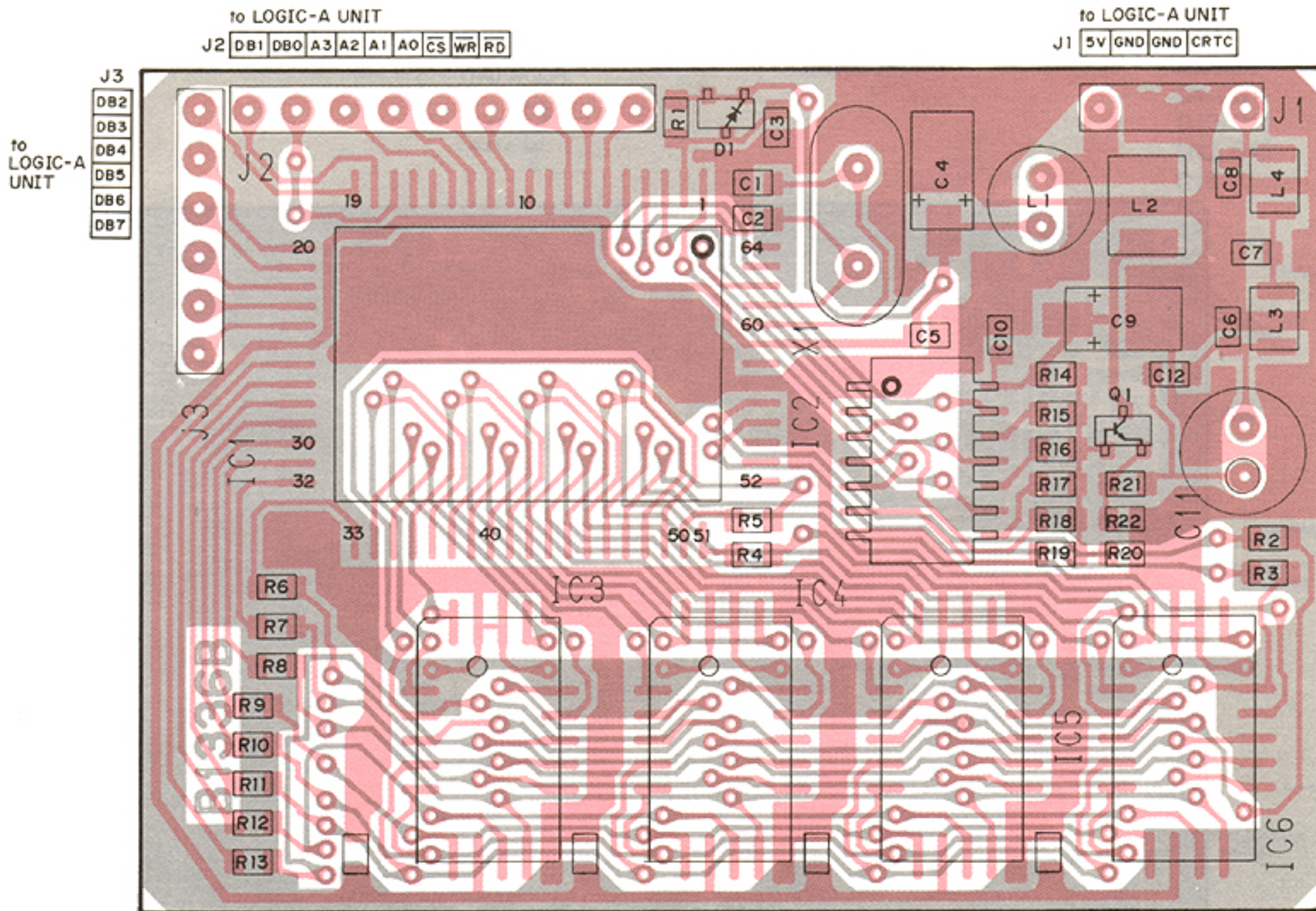

FOIL SIDE  
 COMPONENT SIDE

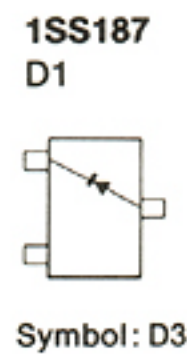
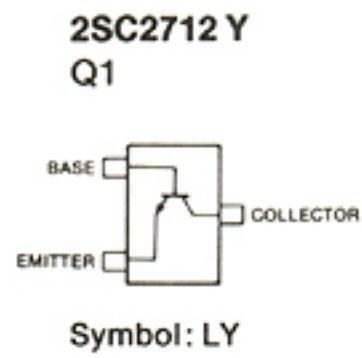



• LOGIC-A UNIT

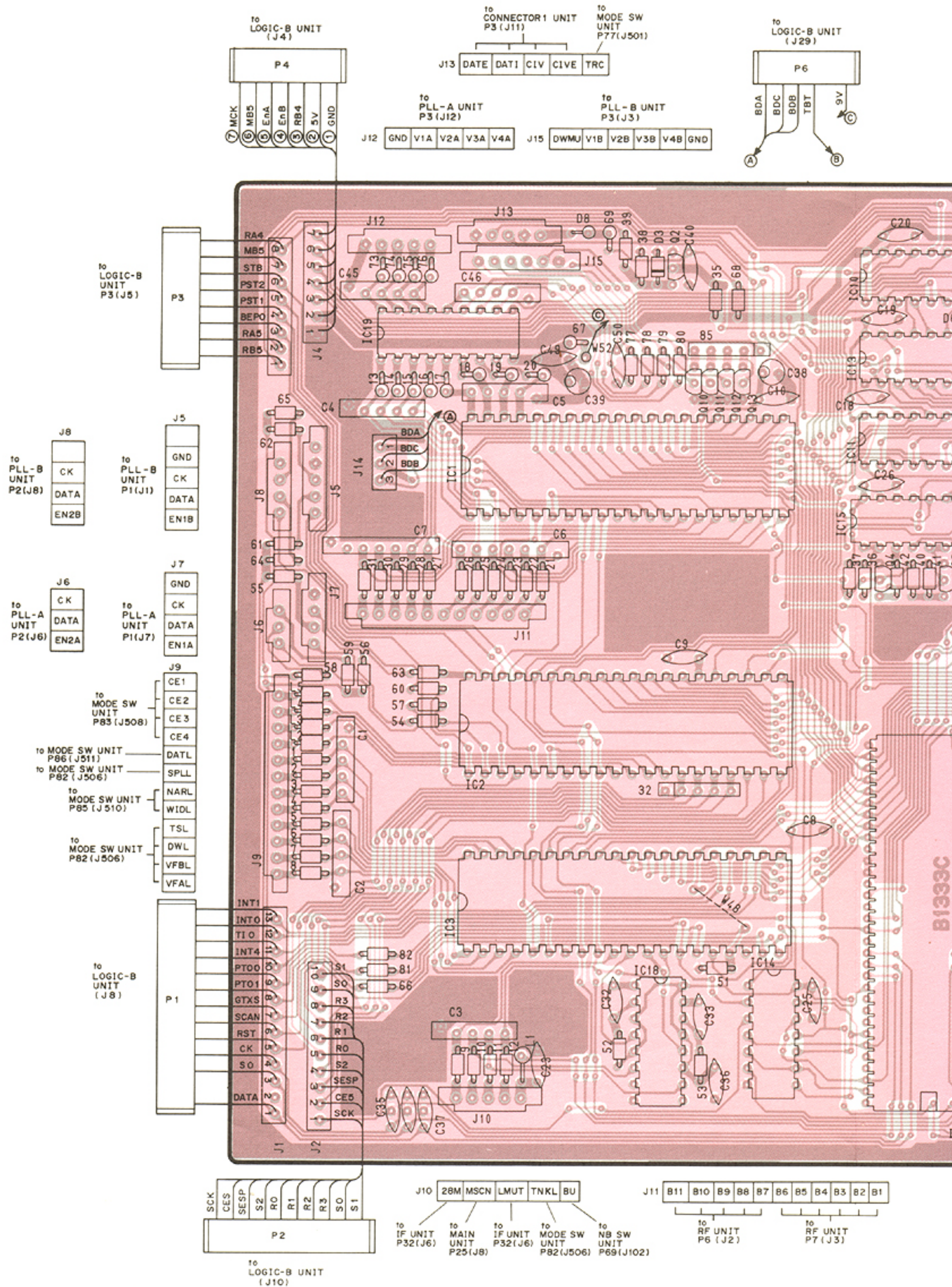



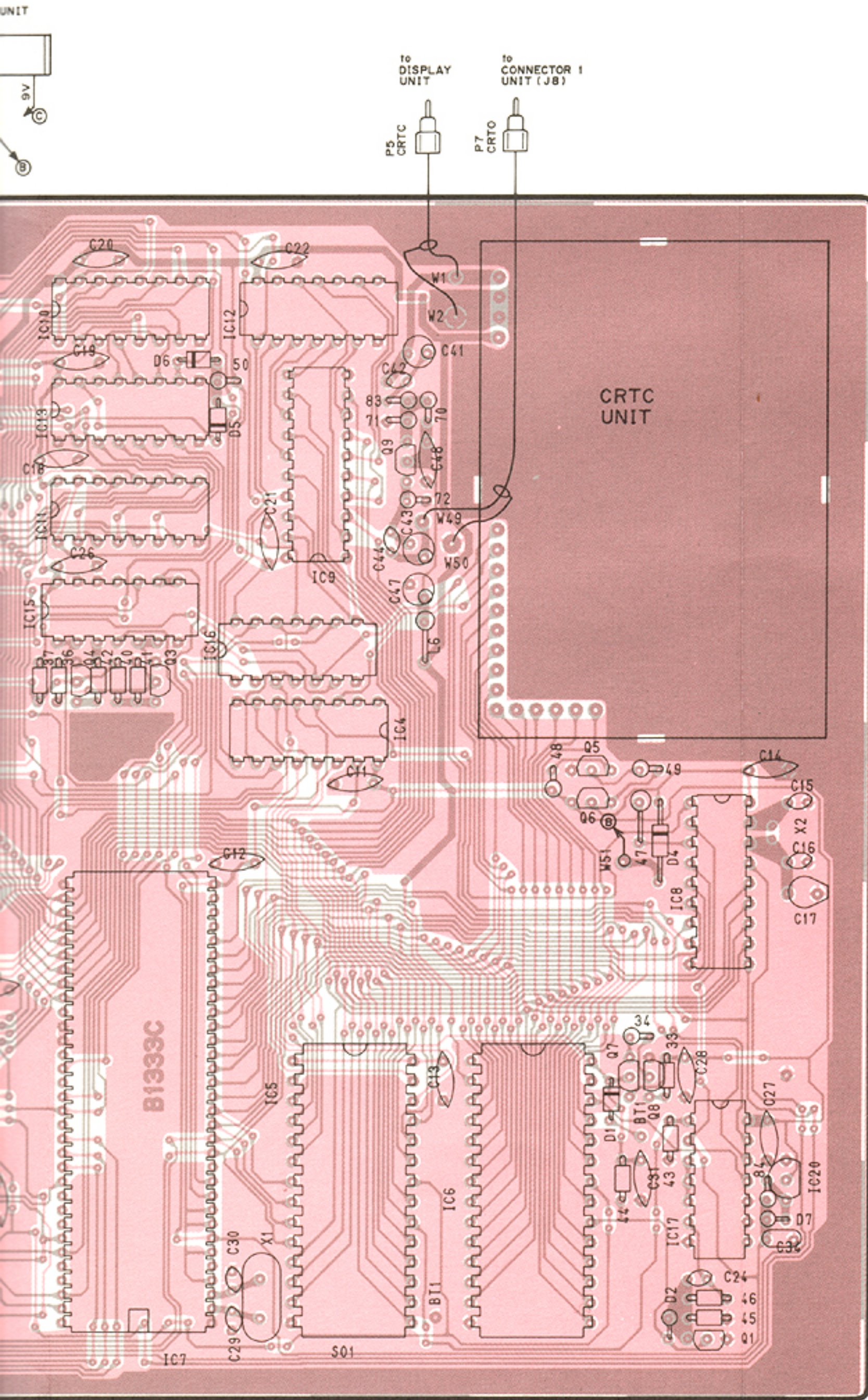

**2SA1048 Y**  
Q6, Q7



**2SC1214**  
Q9

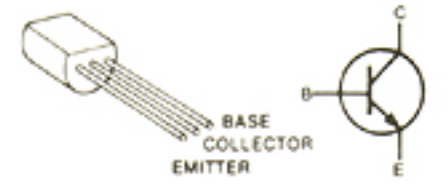

**2SC2458 Y**  
Q1, Q2  
Q3, Q4



**2SC2785 EF**  
Q10, Q11  
Q12, Q13

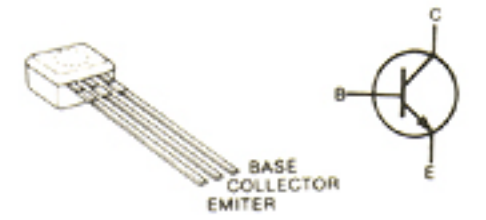

**RN1204**  
Q5, Q8

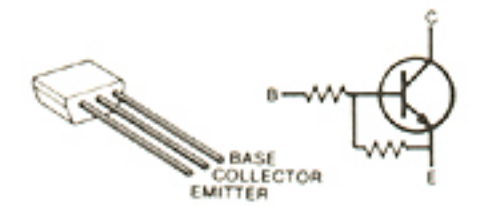

B4 B3 B2 B1  
UNIT  
(J3)

FOIL SIDE  
COMPONENT SIDE



# 7-10 LOGIC-B UNIT

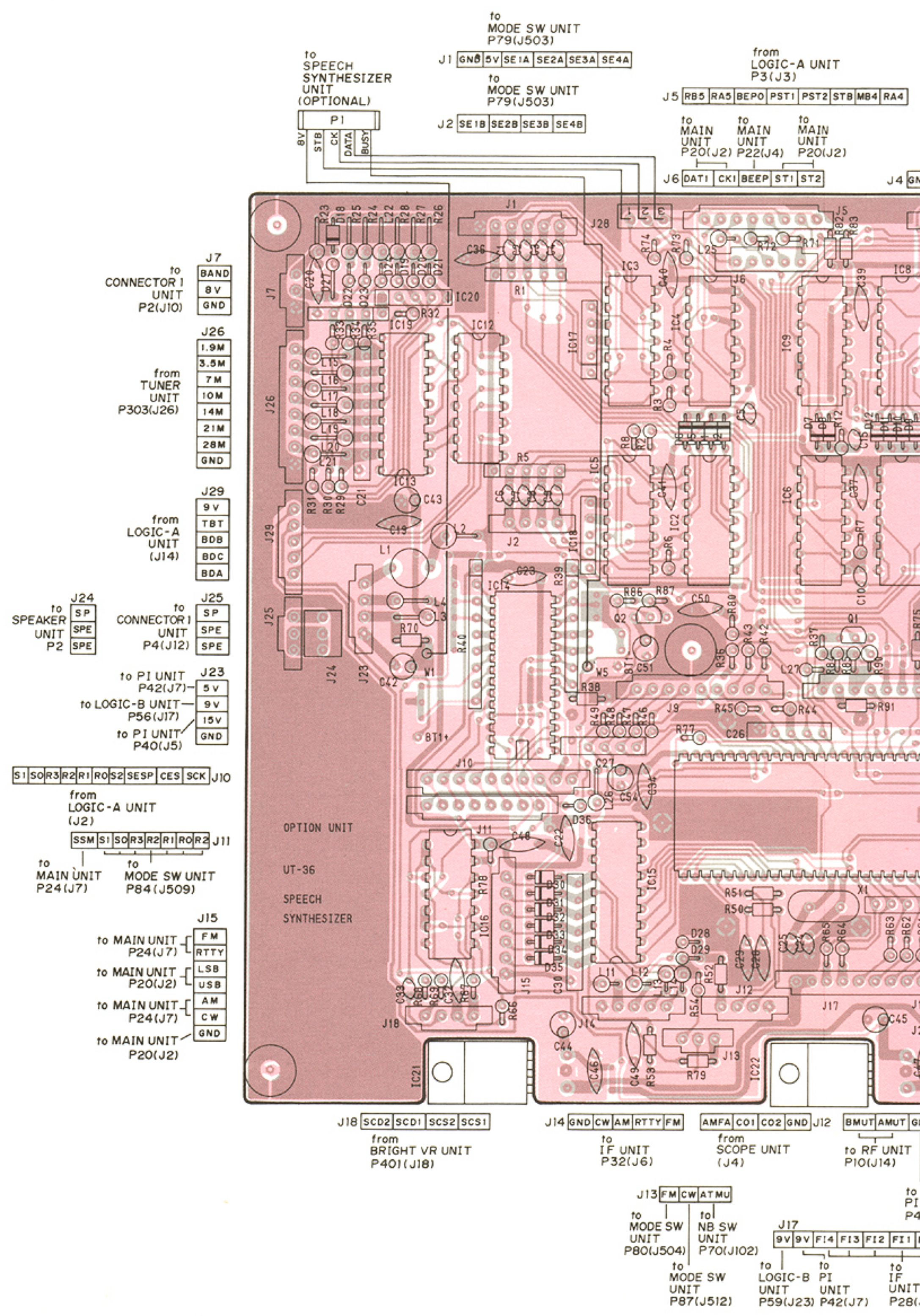



from  
LOGIC-A UNIT  
P3(J3)

EPO PST1 PST2 STB MB4 RA4

to  
MAIN  
UNIT  
P22(J4)

KEEP ST1 ST2

from  
LOGIC-A  
UNIT  
P4(J4)

J4 GND 5V RB4 EnB EnA MB5 MCK

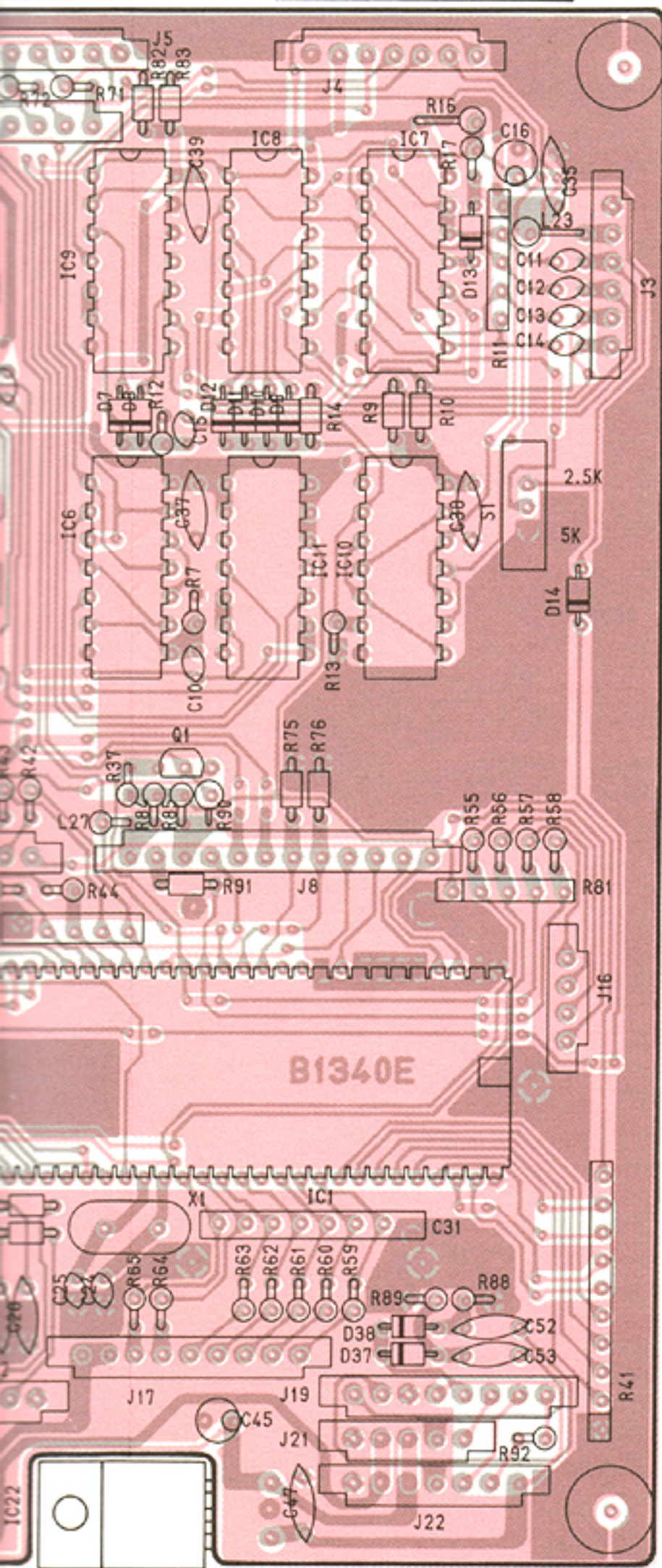

J3  
GND  
5V  
SE1M  
SE2M  
SE3M  
SE4M

to  
MODE SW  
UNIT  
P81(J505)

from  
SCOPE  
UNIT  
P2(J2)

from  
SCOPE  
UNIT  
P2(J4)

J9 DV4 DV5 DV6 DV7 DV0 DV1 DV2 DV3 SH

from  
LOGIC-A  
UNIT  
P1(J1)

J8  
DATA SO CK RST SCAN GTXS PTOO INT4 TIO INTO INTI

J16  
DAT2  
CK  
ST4  
ST3

to  
MAIN  
UNIT  
P20(J2)

from  
PLL-B  
UNIT  
P4

J21 GND 5V 9V BMUT DWMU

from  
PLL-A  
UNIT  
P4(J22)

J22 GND 5V 9V AMUT CAL MAKE 15V

J12 BMUT AMUT GND 15V MUTE DWMU CAL MAKE J19

to RF UNIT P10(J14) to PI UNIT P40(J5) to MODE SW UNIT P81(J505) to MODE SW UNIT P78(J502)

to PI UNIT P4(J6) to IF UNIT P30(J4) to BRIGHT VR UNIT P63(J404)

J17  
9V 9V F14 F13 F12 F11 F17 F16 F15

to LOGIC-B UNIT P59(J23) to PI UNIT P42(J7) to IF UNIT P28(J2)

2SA1048 Y  
Q1



2SC2458 GR  
Q2

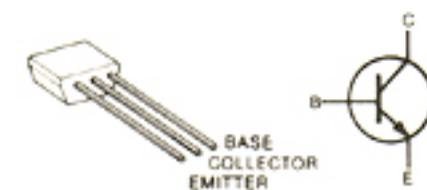

FOIL SIDE  
COMPONENT SIDE



# 7-11 SCOPE UNIT

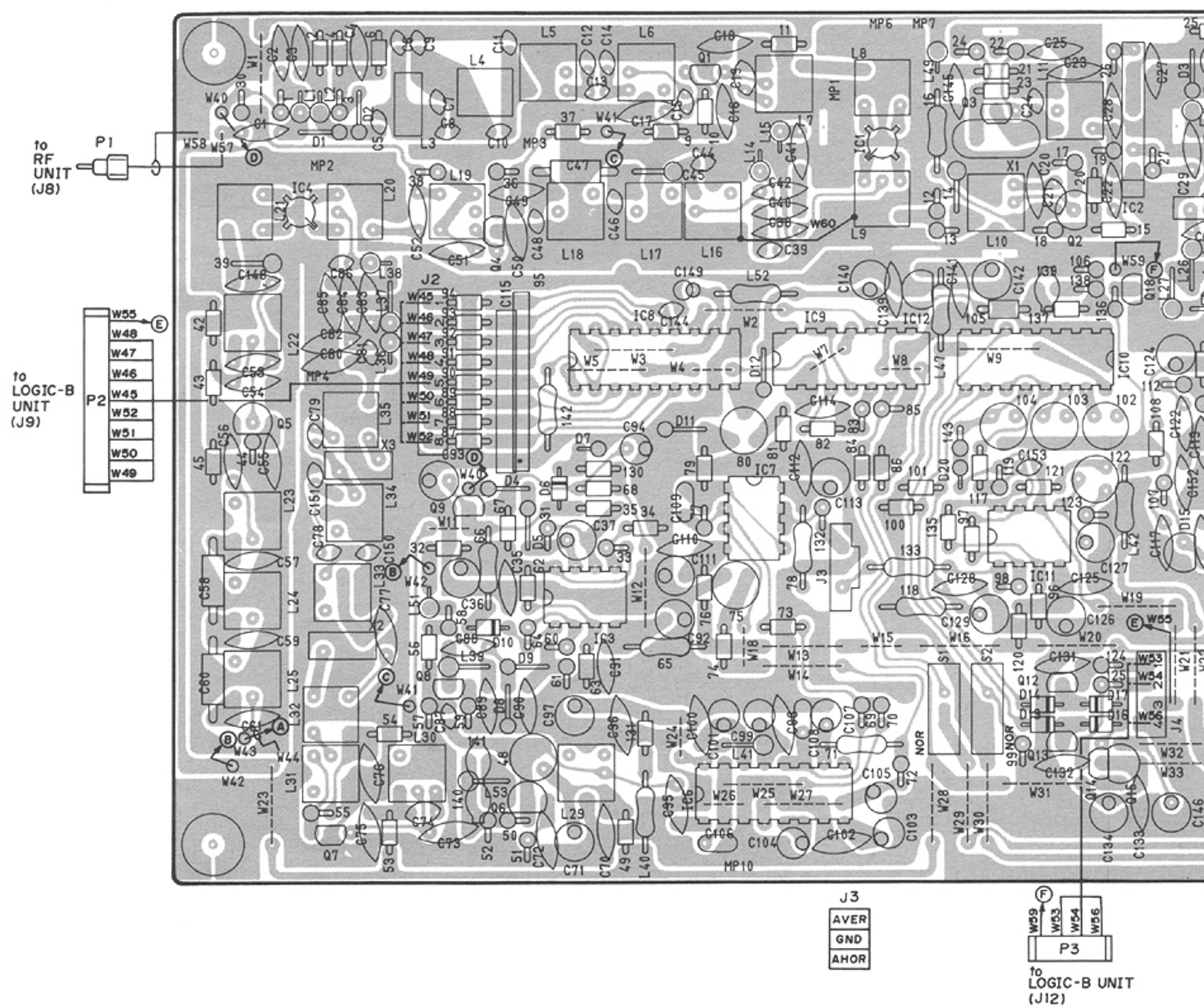



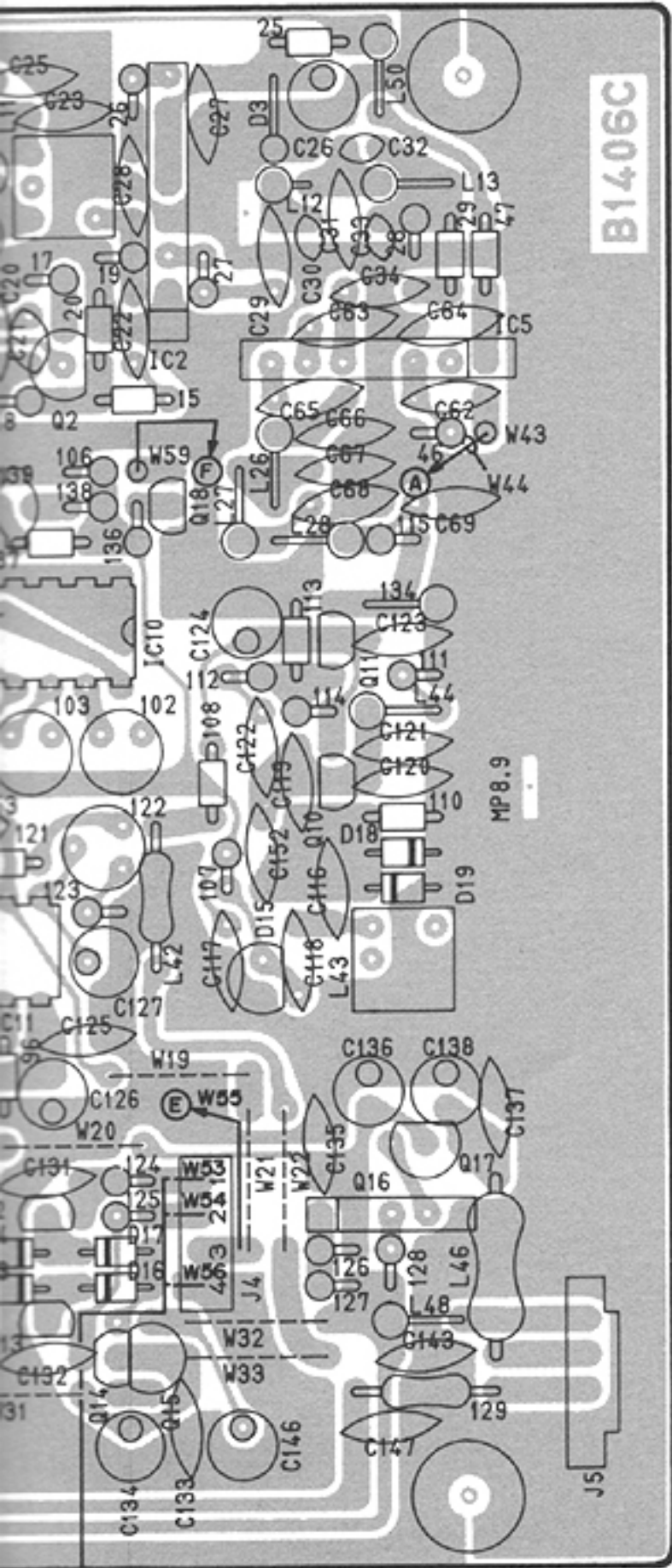

**J5** to PI UNIT P42(J7)  
**9V** to TUNER UNIT P15(J104)  
**-15V** to MODE SW UNIT P78(J502)  
**T9V** to PI UNIT P41(J6)  
**GND**

**2SA798 G**  
Q16

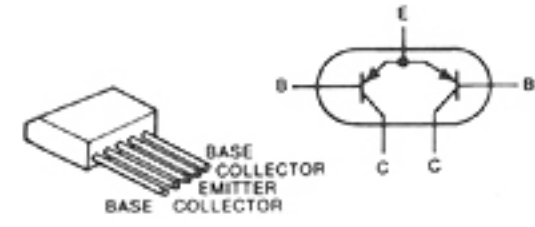

**2SK241 GR**  
Q1, Q4  
Q7, Q10

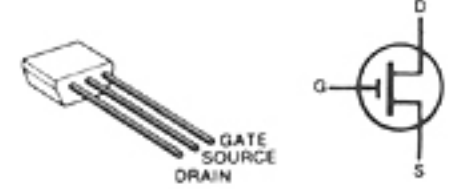

**2SA1048 GR**  
Q9



**RN1204**  
Q12, Q13  
Q18

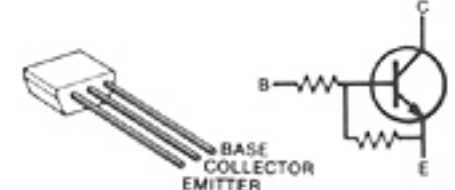

**2SB562 C**  
Q15



**RN2202**  
Q14

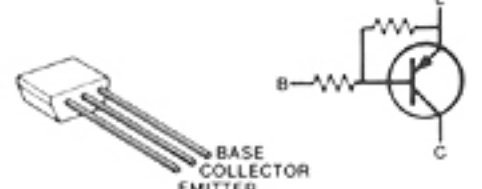

**2SC763 C**  
Q5

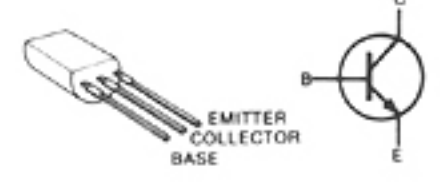

**2SC2053**  
Q2, Q6

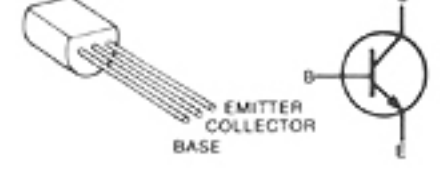

**2SC2458 GR**  
Q8, Q11

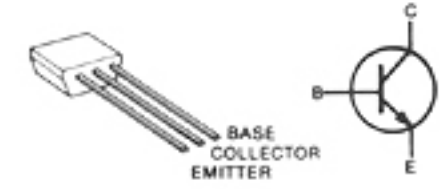

**2SC2668 Y**  
Q3

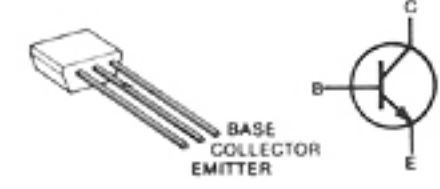

**2SD468 C**  
Q17

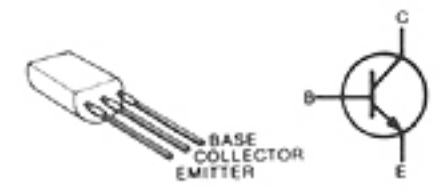

# 7-12 PI UNIT

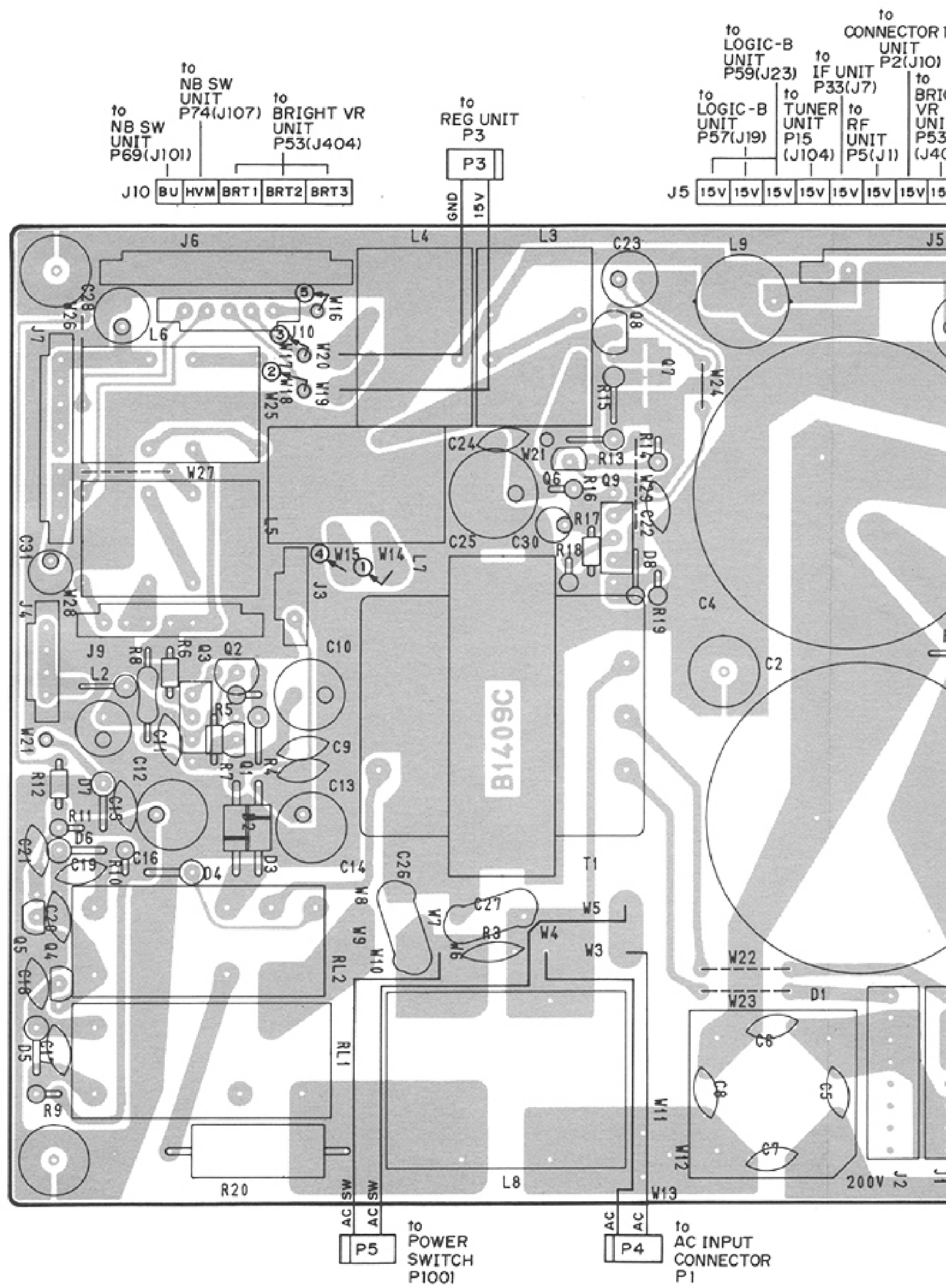
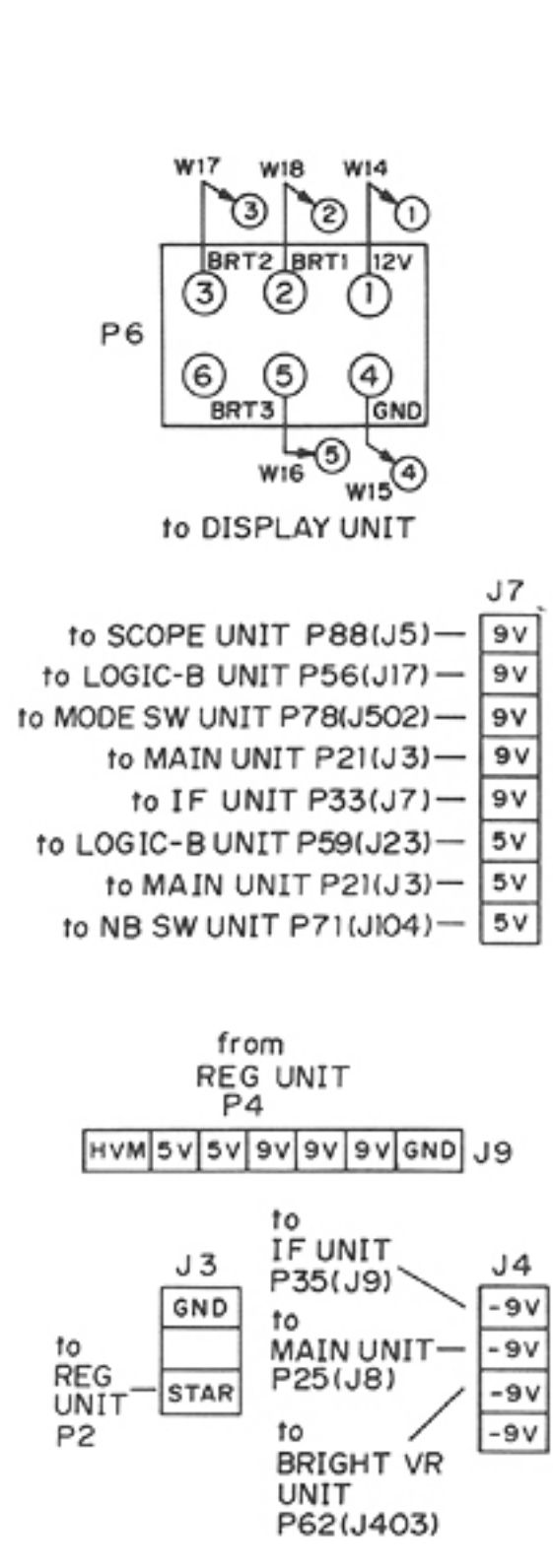

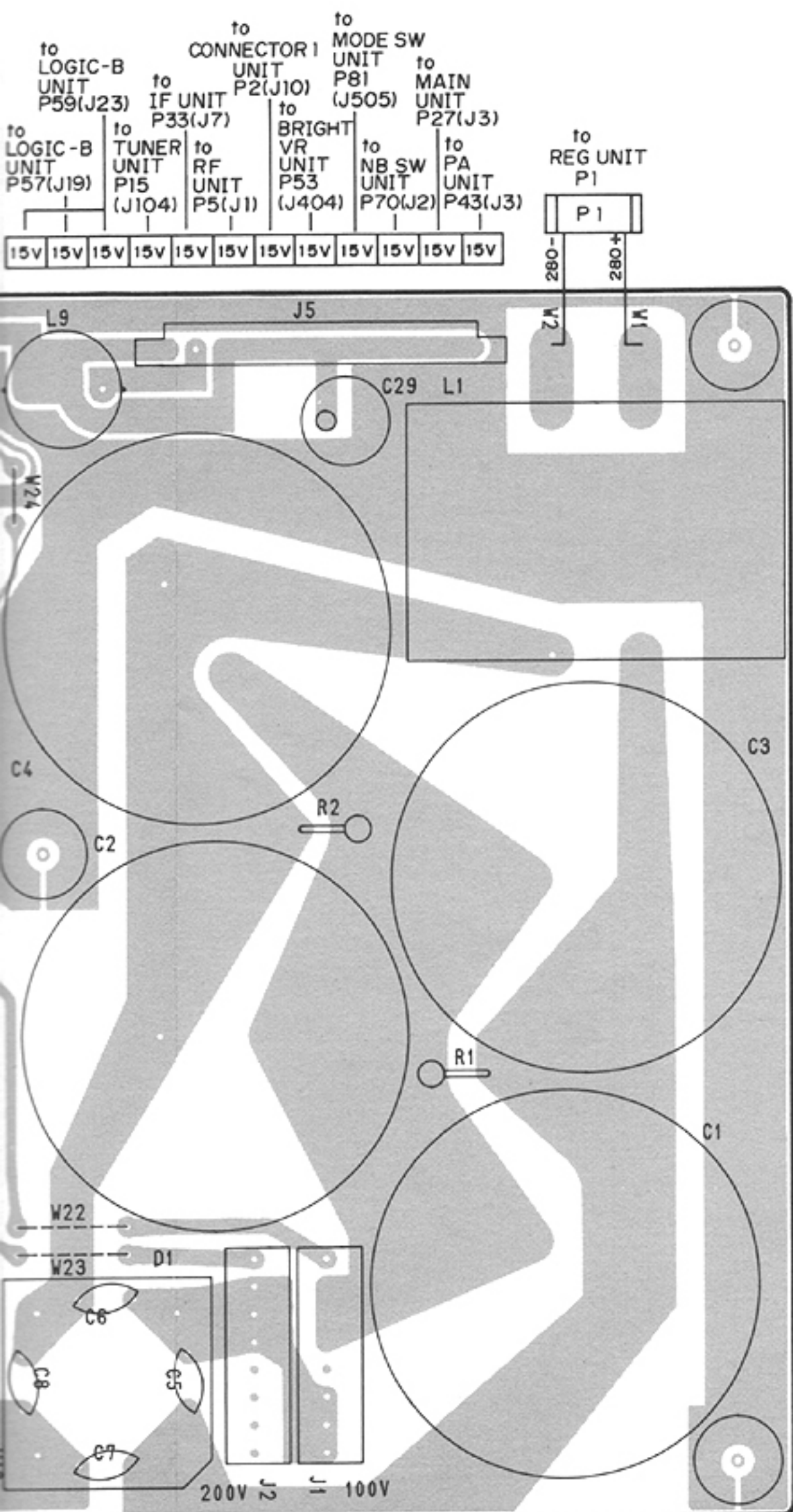

AC INPUT  
CONNECTOR  
1

**2SA798 G**  
Q3

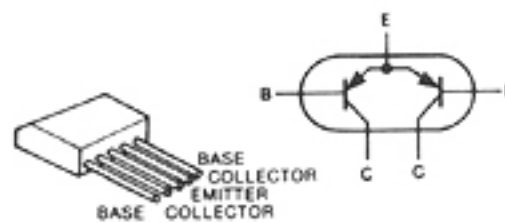

**2SA1048 Y**  
Q6

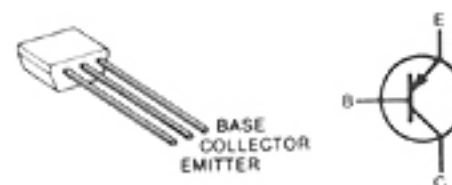

**2SB562 C**  
Q8

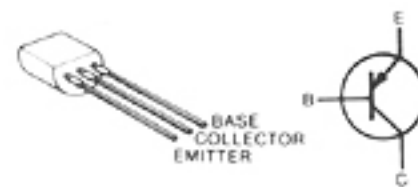

**2SB1019 Y**  
Q7

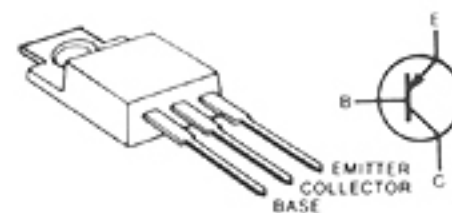

**2SC1583 G**  
Q9

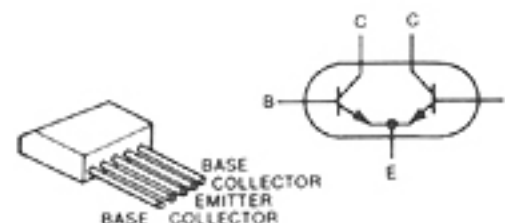

**2SC2458 Y**  
Q1

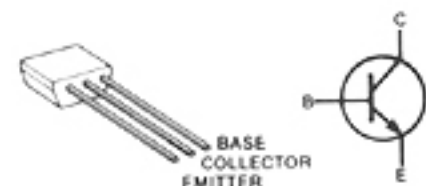

**2SD468 C**  
Q2

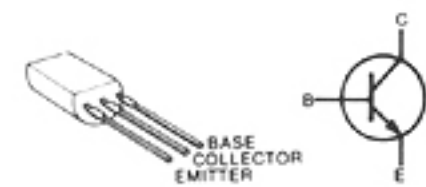

**RN1202**  
Q4, Q5

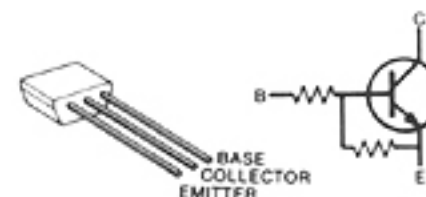



# 7-13 PA UNIT

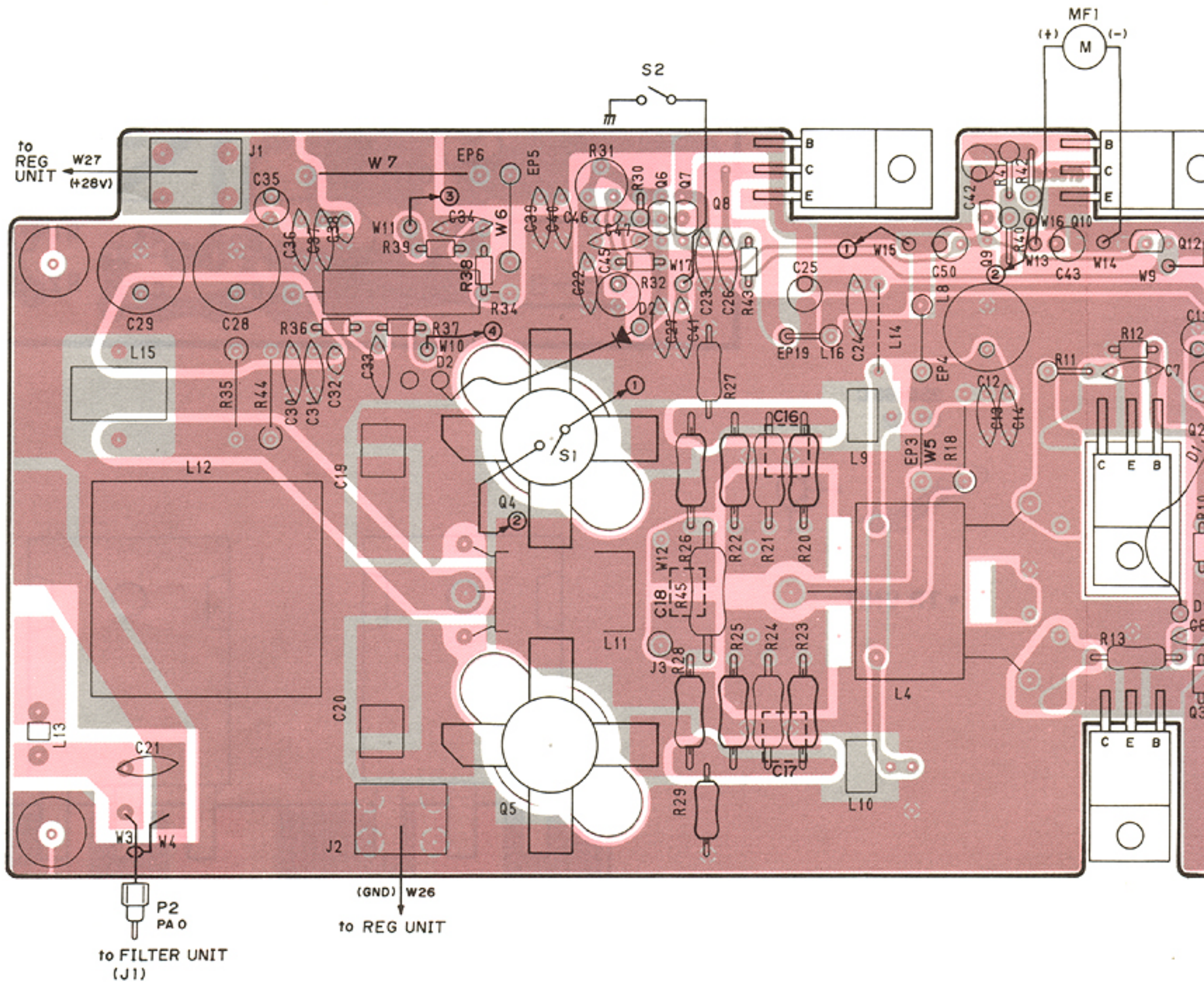



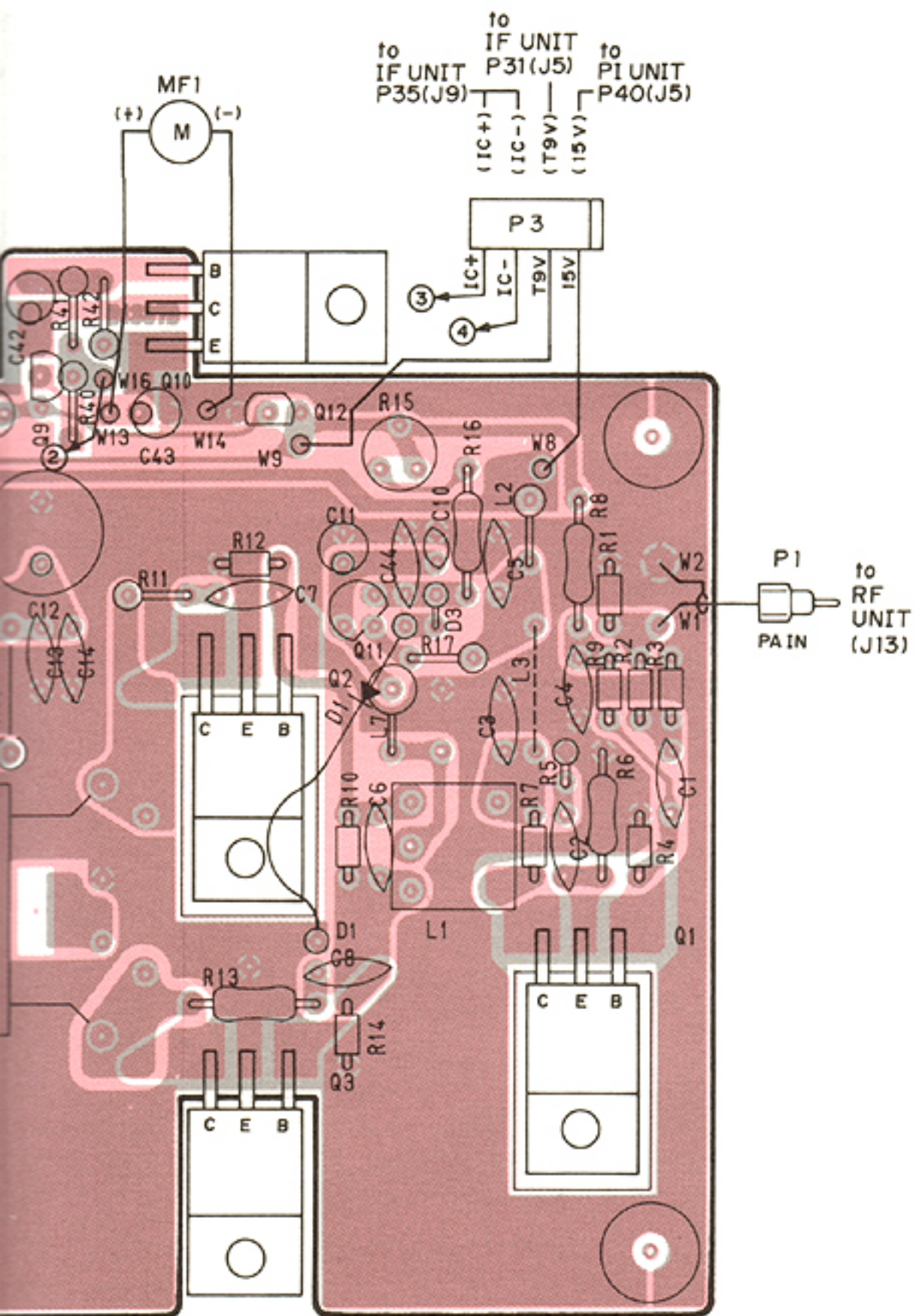

**2SC1971**  
Q1

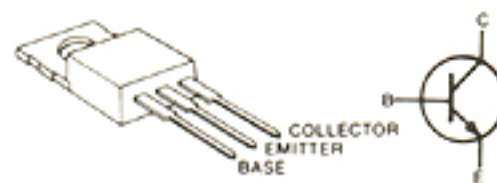

**2SC2785 EF**  
Q6, Q7

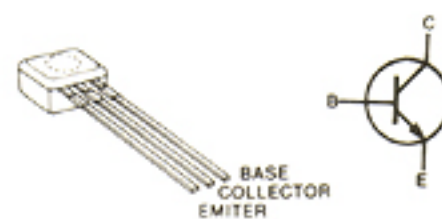

**2SD468 C**  
Q11

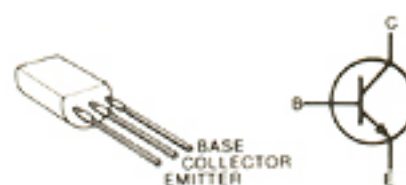

**2SD1406 Y**  
Q8, Q10

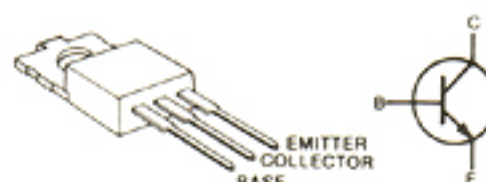

**RN1204**  
Q12

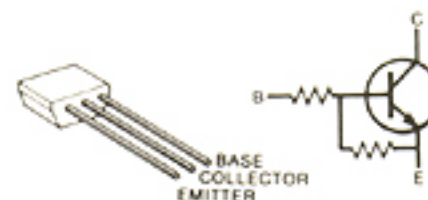

**RN2204**  
Q9



**MRF422**  
Q4, Q5

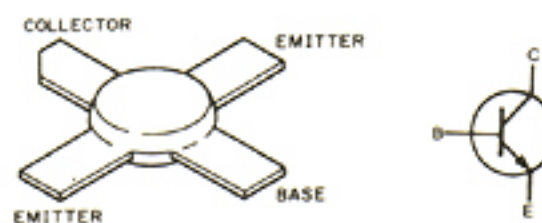

**MRF486**  
Q2, Q3

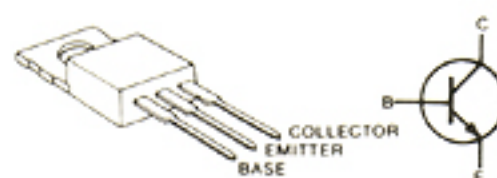



# 7-14 REG, TR, DI AND DC-DC UNITS

## • DC-DC UNIT

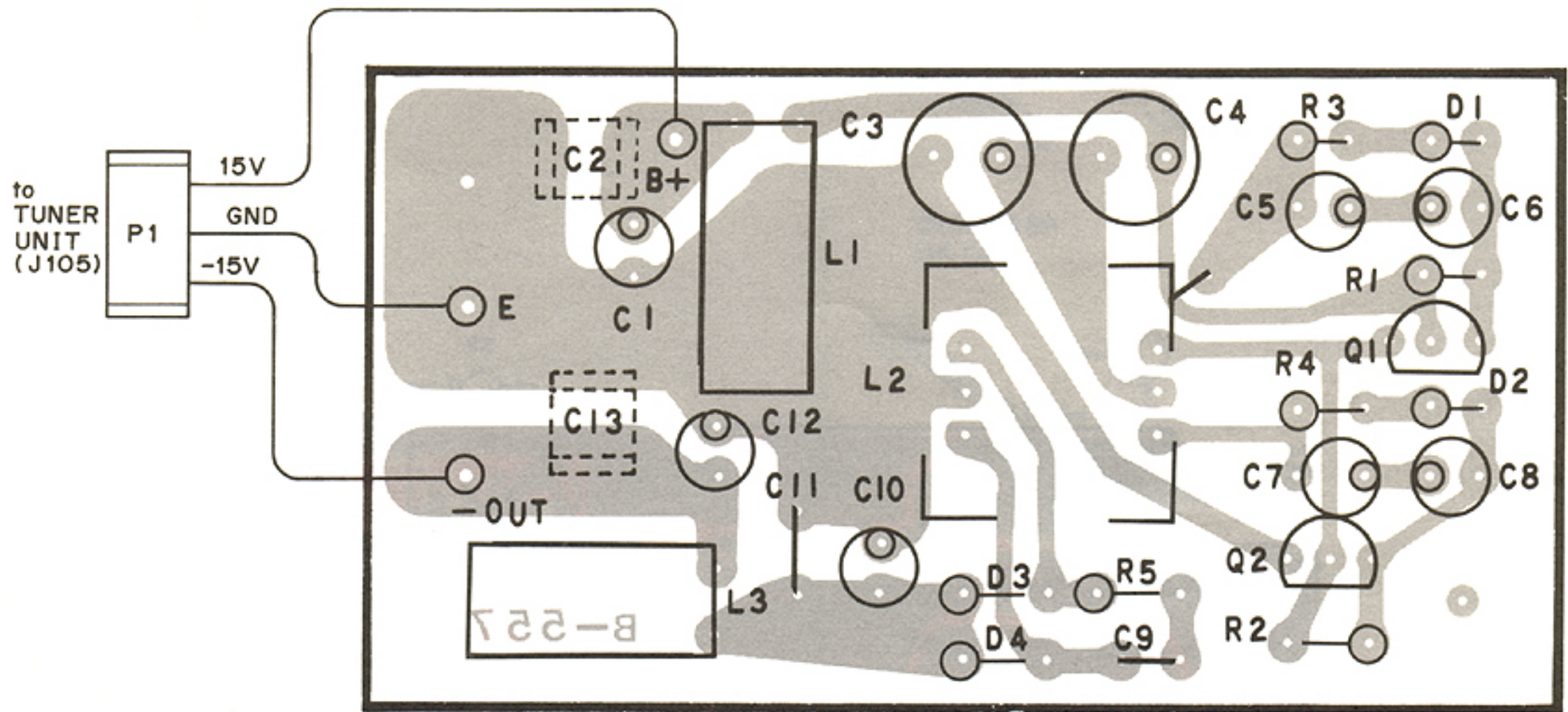

2SD468 C  
Q1, Q2

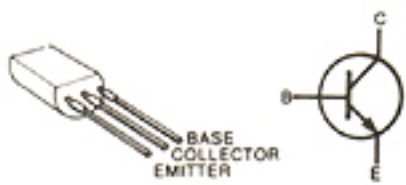

## • TR UNIT

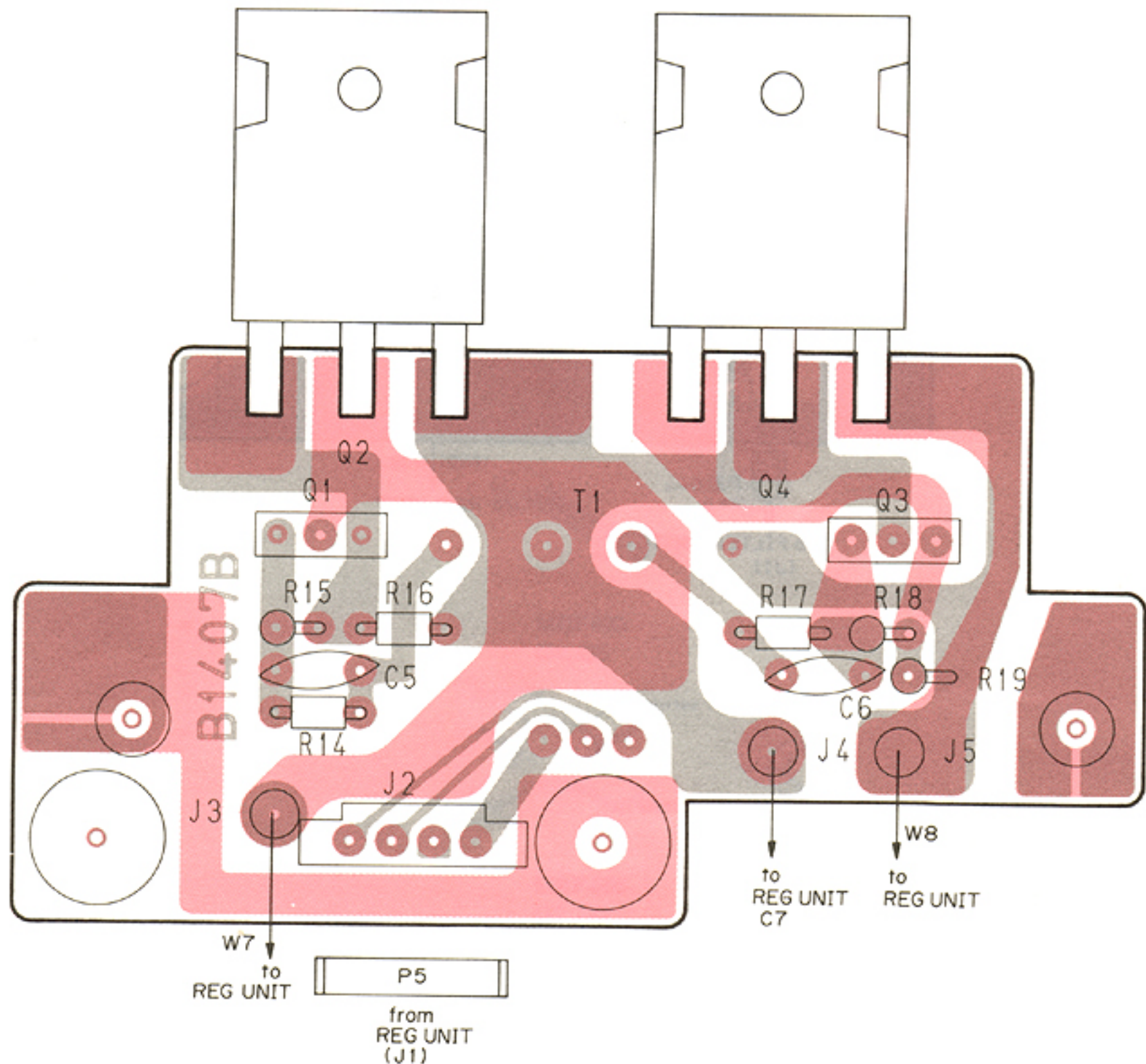

2SC3162  
Q1, Q3

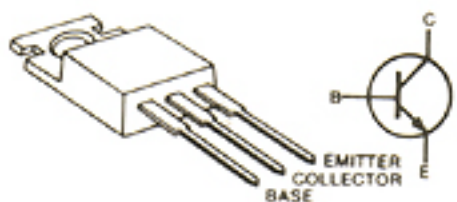

2SC3164  
Q2, Q4



FOIL SIDE  
COMPONENT SIDE



• REG UNIT

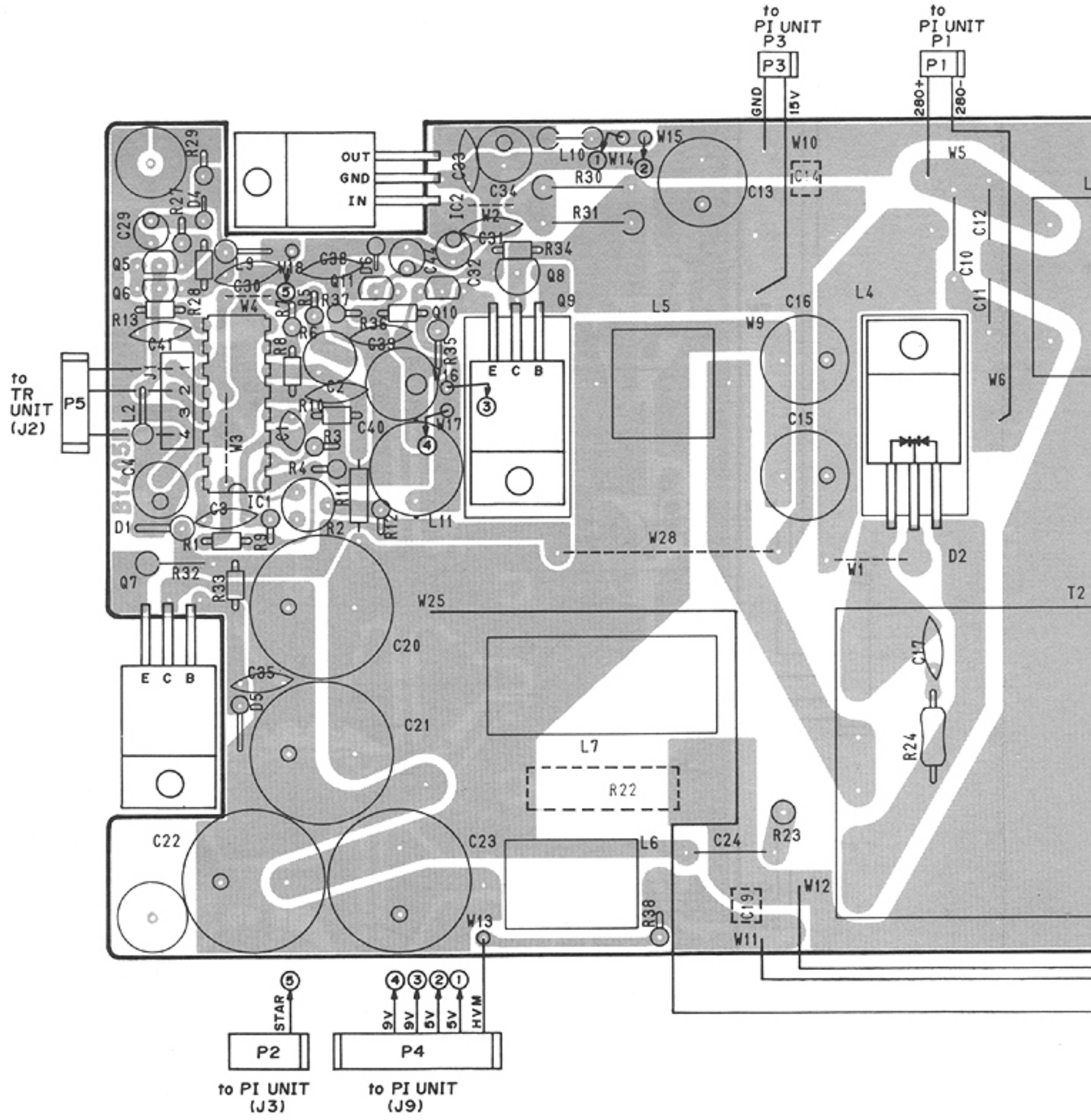

**2SA1048 GR**  
Q5, Q6



**2SC2458 GR**  
Q10, Q11

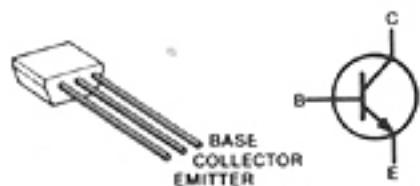

**2SD468 C**  
Q8

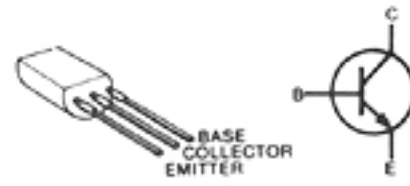

**2SD1406 Y**  
Q7, Q9

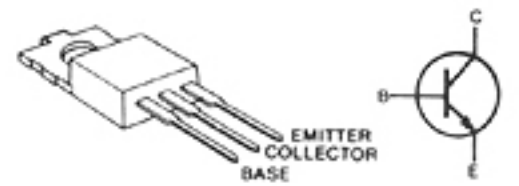

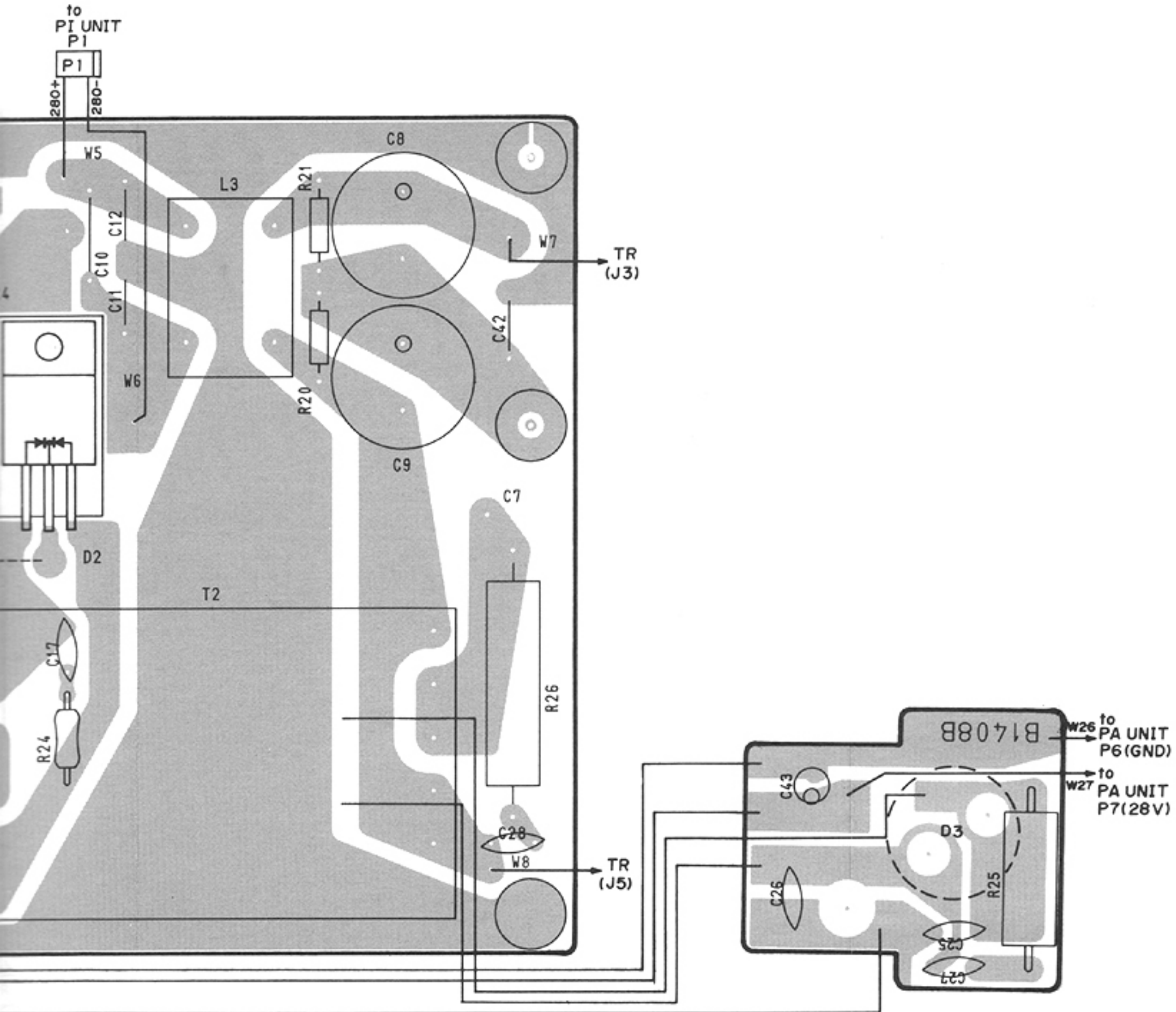

406 Y  
9





# 7-15 FILTER UNIT

• DI UNIT

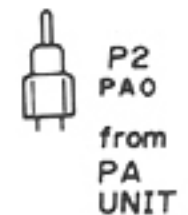
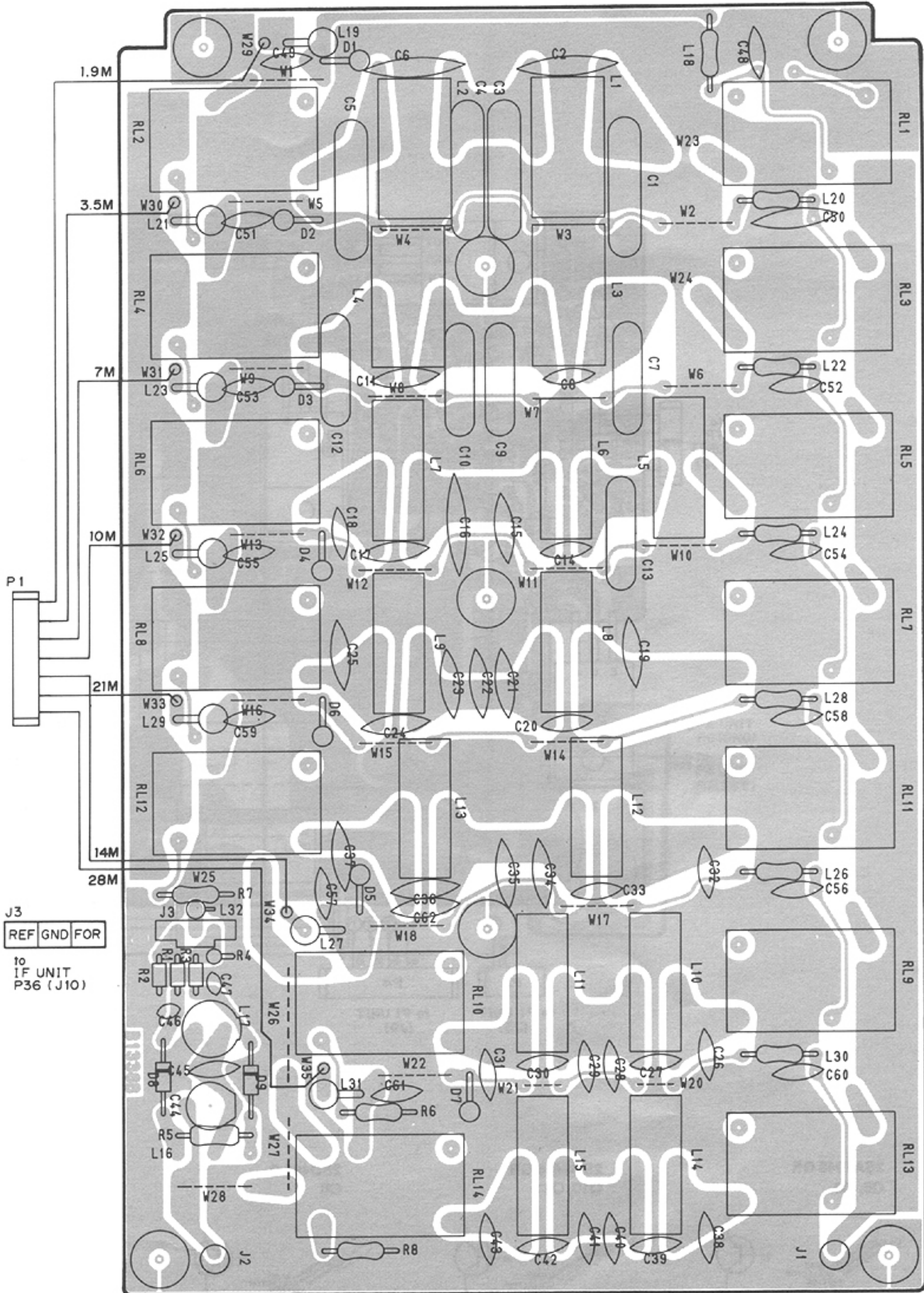



# 7-16 TUNER UNIT

## • PRESET

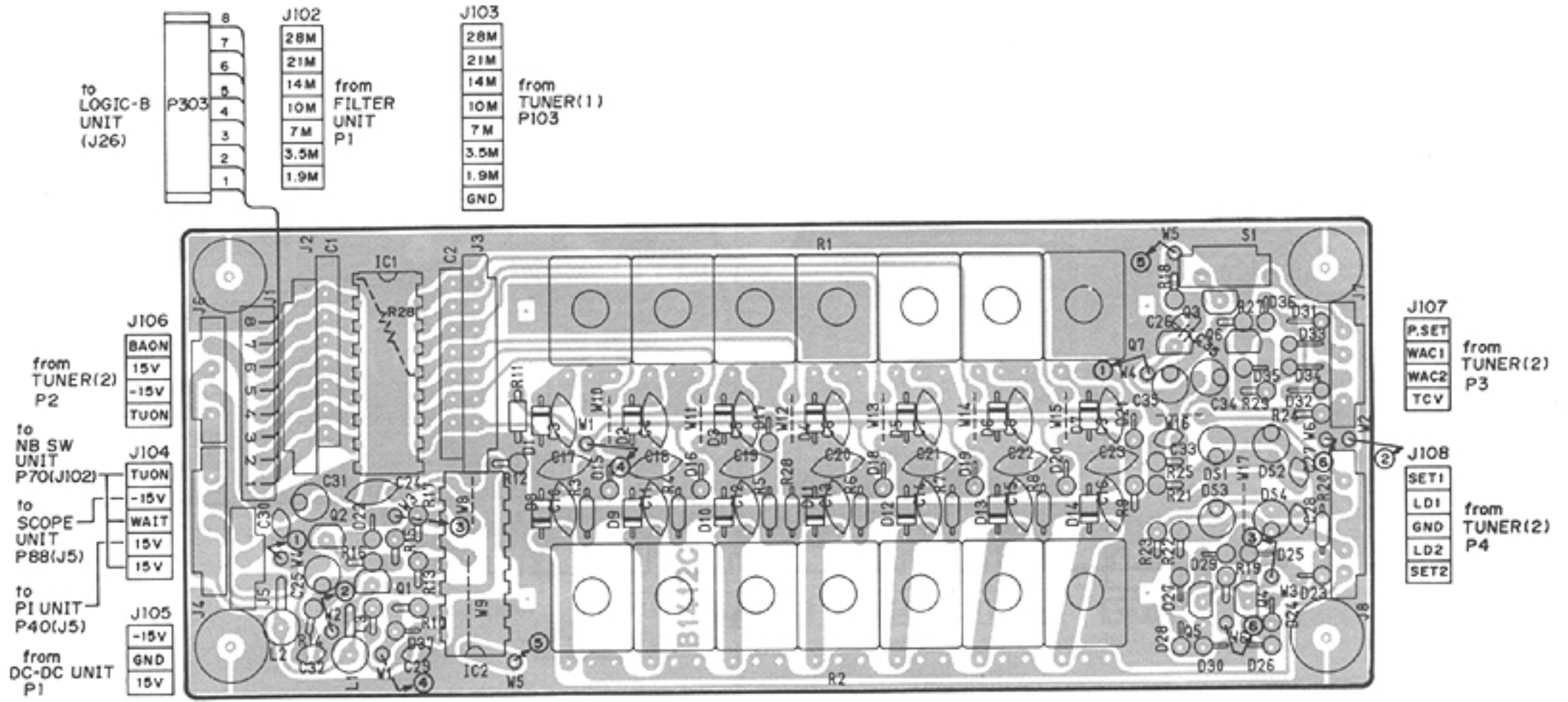

**2SA1348**  
Q106

**2SC2785 EF**  
Q101, Q102  
Q103, Q104  
Q105

**2SC3402**  
Q107

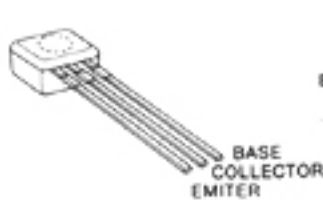

**NOTE:** Add "100" to the indicated number on the unit for actual parts number respectively.

## • TUNER 1

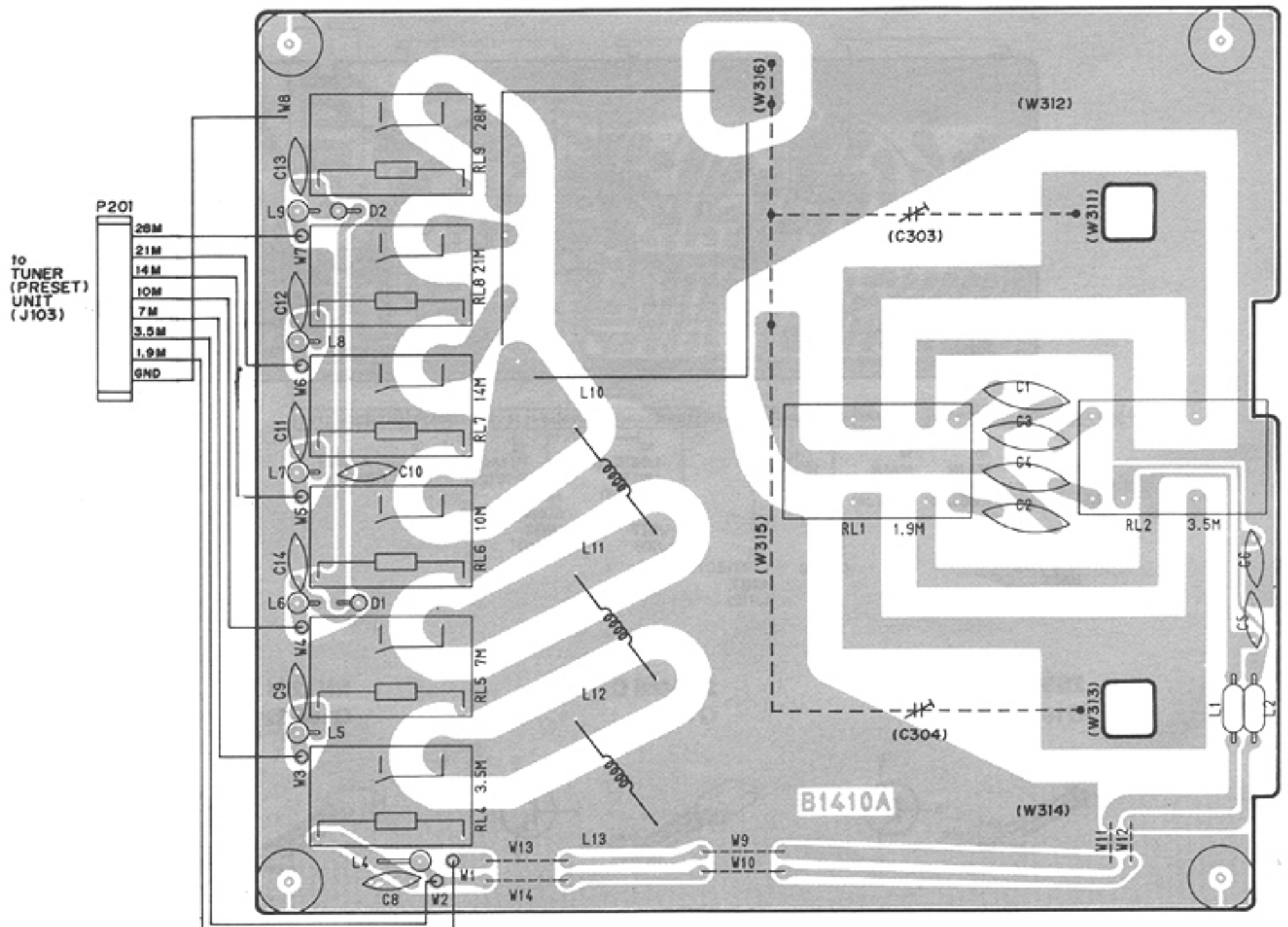

**NOTE:** Add "200" to the indicated number on the unit for actual parts number respectively.



• TUNER 2

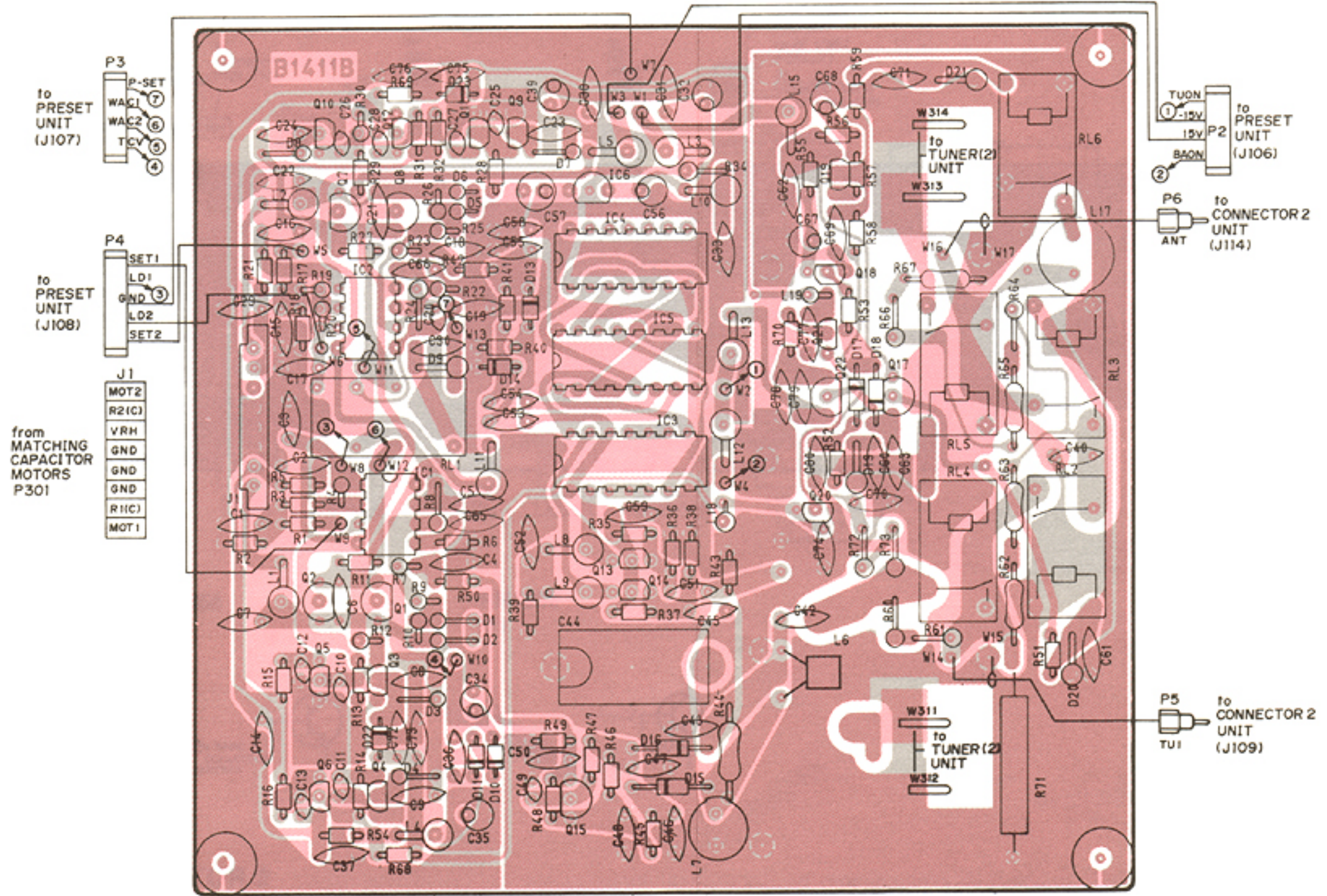

FOIL SIDE  
COMPONENT SIDE

**2SA1048 Y/GR**  
Q4, Q6  
Q10, Q12  
Q19



**2SB562 C**  
Q2, Q8  
Q17, Q22



**2SC1740 S**  
Q13, Q14



**2SC2785 EF**  
Q3, Q5  
Q9, Q11

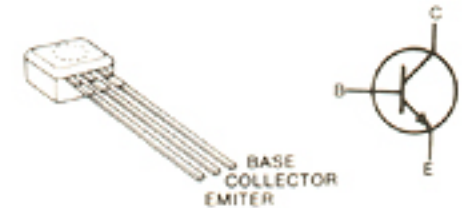

**2SD468 C**  
Q1, Q7

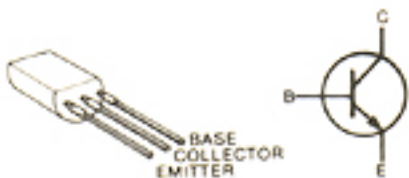

**2SK30A/TM/Y**  
Q15

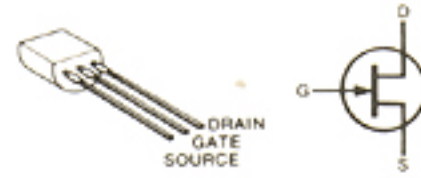

**RN1202**  
Q18

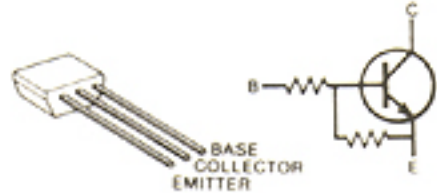

**RN1204**  
Q20, Q21

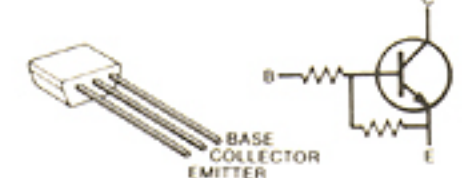



# 7-17 EF (CONNECTOR 1, 2) UNIT

## • CONNECTOR 1

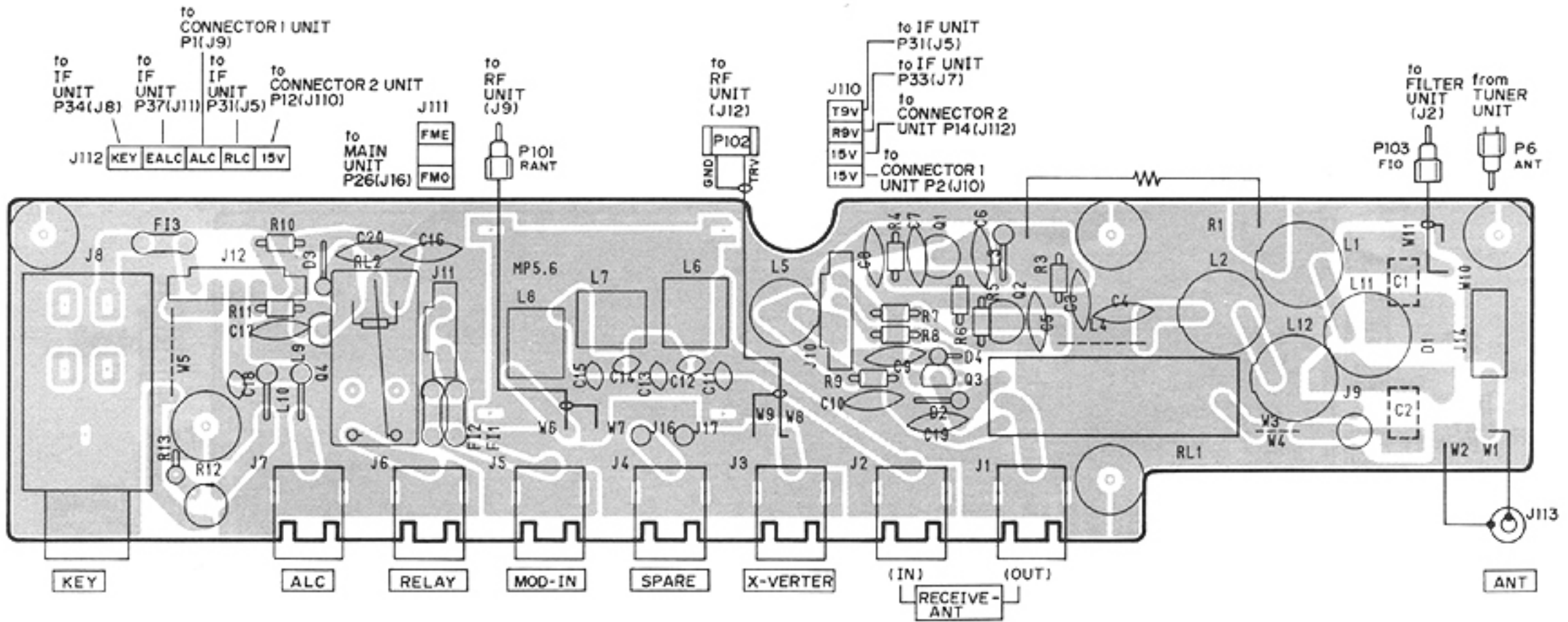

**2SC2458**  
Q2

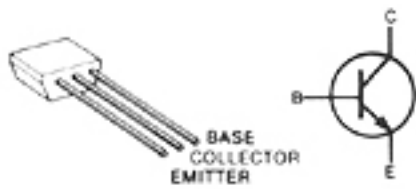

**RN1202**  
Q1

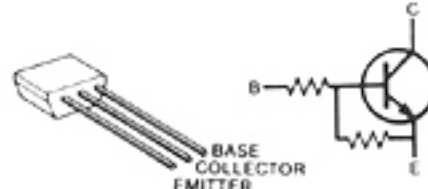

## • CONNECTOR 2

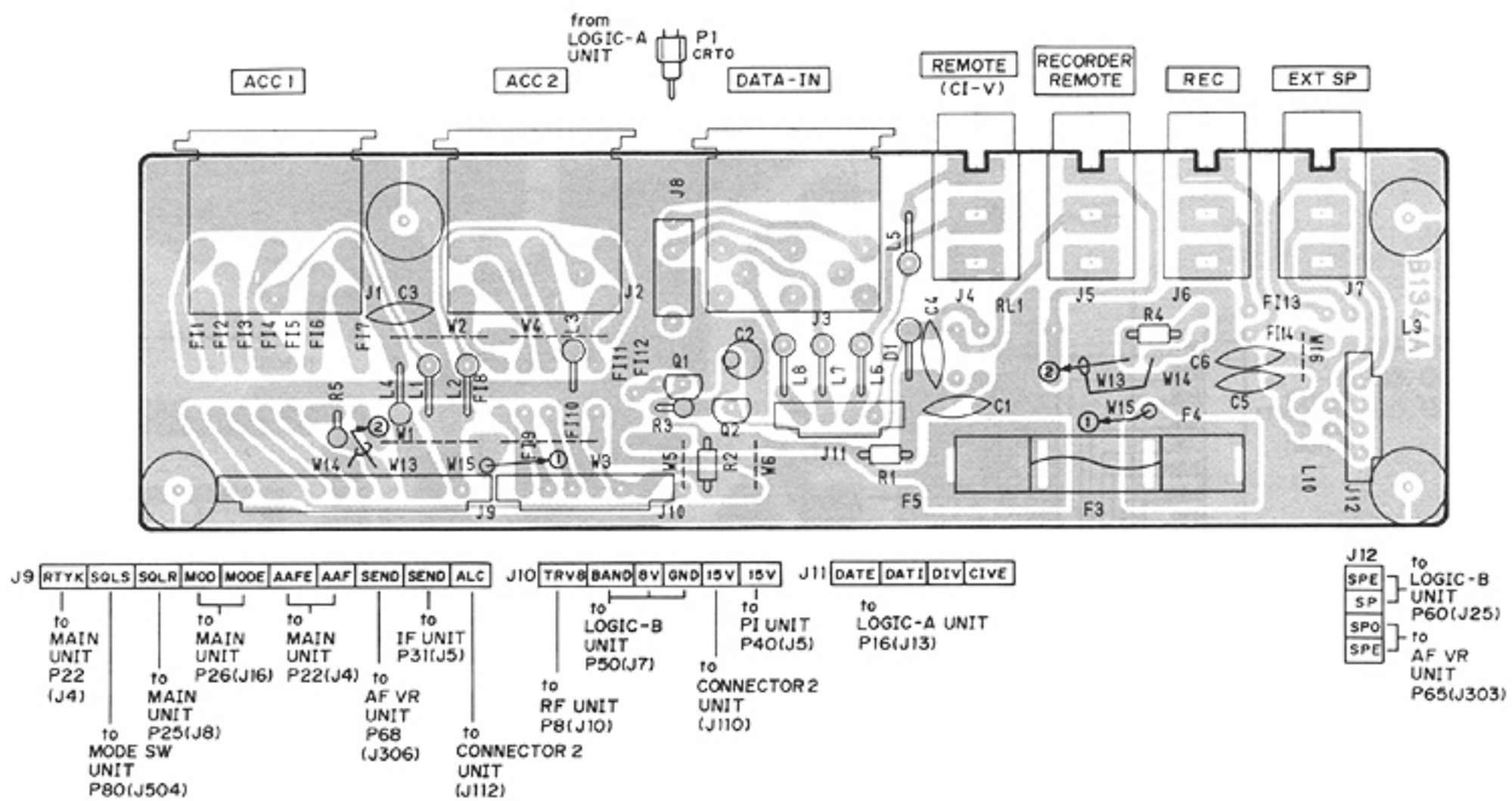

**2SB562 C**  
Q101



**2SD468 C**  
Q102

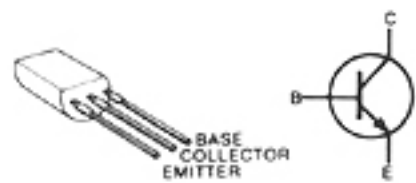

**RN1204**  
Q103, Q104



NOTE: Add "100" to the indicated number on the unit for actual parts number respectively.



# SECTION 8 IC PIN CONNECTIONS

**BA3812L**  
(5-POINT GRAPHIC EQUALIZER)

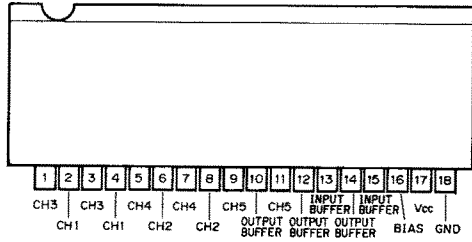

**DAN401**  
(SWITCHING DIODE ARRAY)

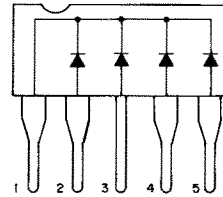

**HD10551**  
(PRESCALER)

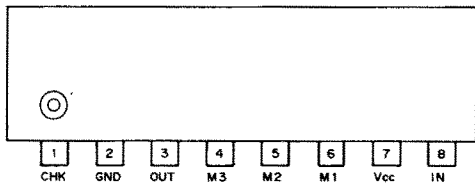

**HD64B180ROP**  
(CPU)

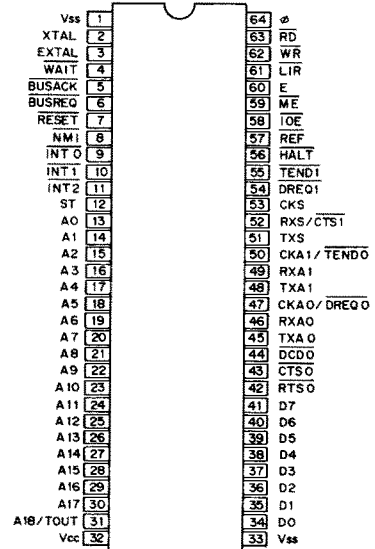

**HM50464CP-12**  
(RAM)

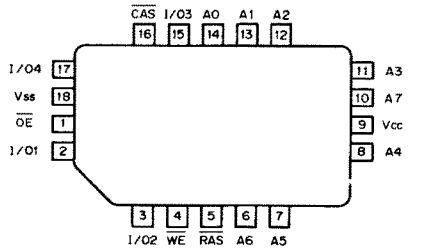

**LA6393M**  
(DUAL COMPARATOR)

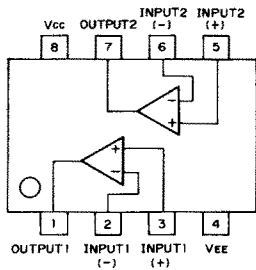

**M50784SP**  
(INPUT/OUTPUT EXPANDER)

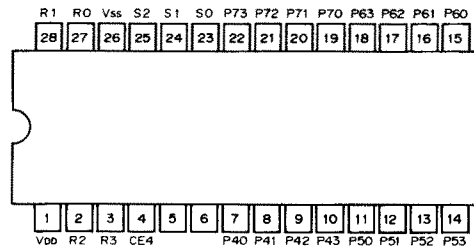

**M5218L**  
(LOW NOISE DUAL OPERATIONAL AMPLIFIER)

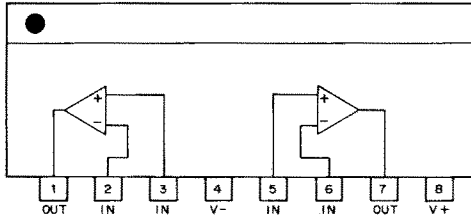

**M54459L**  
(1/20, 1/100 HIGH SPEED DIVIDER)

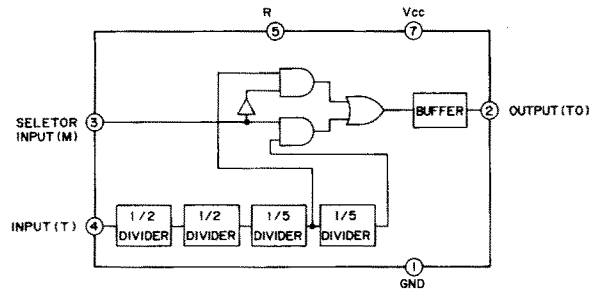

**M54562P**  
(DARLINGTON TRANSISTOR ARRAY)

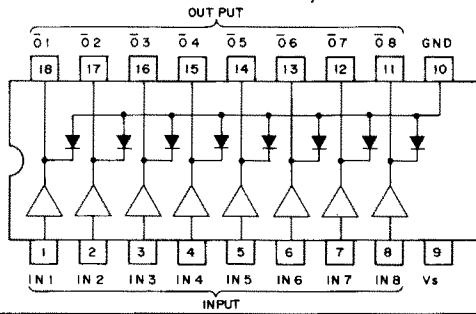

**MC145158P1**  
(SERIAL INPUT PLL FREQUENCY SYNTHESIZER)

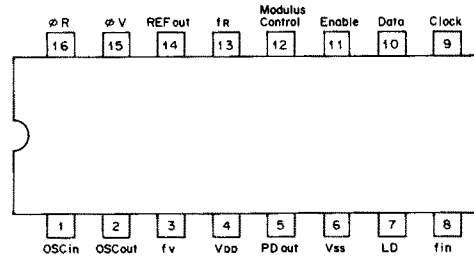

**MC3357P**  
(LOW POWER FM IF)

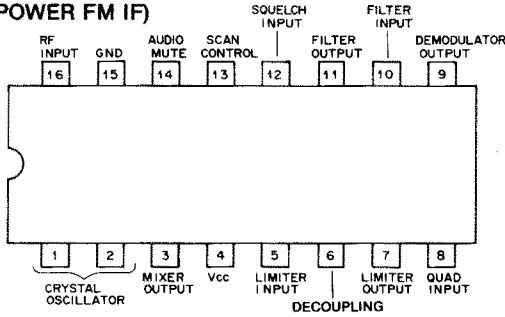

**ND487C1-3R, ND487C2-3R**  
(SCHOTTKY BARRIER DIODE QUAD)

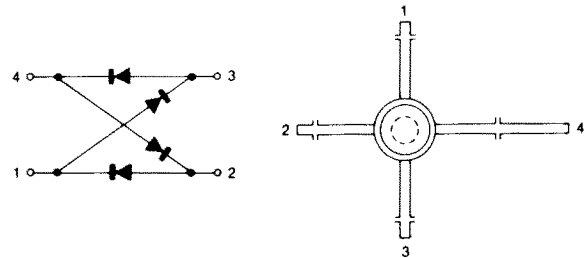

**NJM4558D/M, NJM4560DD**  
(DUAL OPERATIONAL AMPLIFIER)

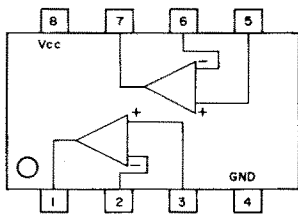

**NJM2204AD**  
(LOG DETECTOR)

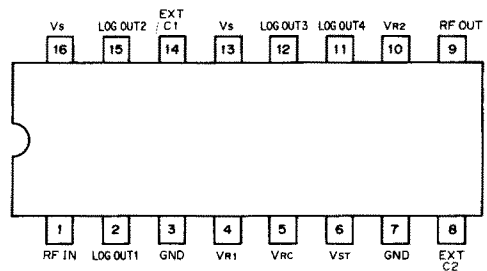

**NJM7805A**  
(3-TERMINAL 5 V REGULATOR)

**NJM7809A**  
(3-TERMINAL 9 V REGULATOR)

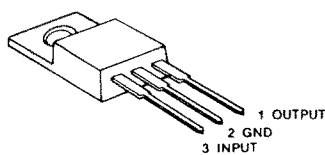

**NJM78L05A**  
(3-TERMINAL 5 V REGULATOR)

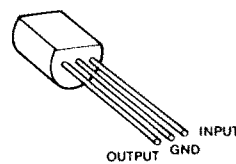

**RF5C16A**  
(DISPLAY CONTROL)

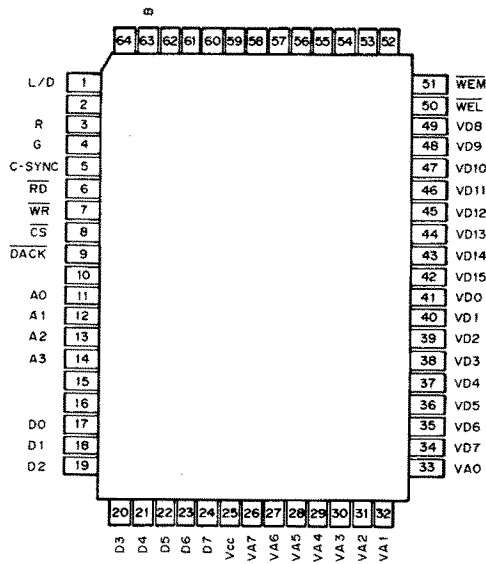

**RP5C15**  
(TIME CLOCK)

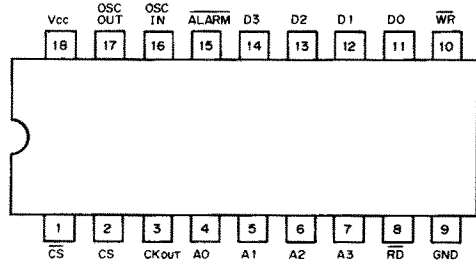

**S7116A**  
(PROGRAMMABLE TONE GENERATOR)

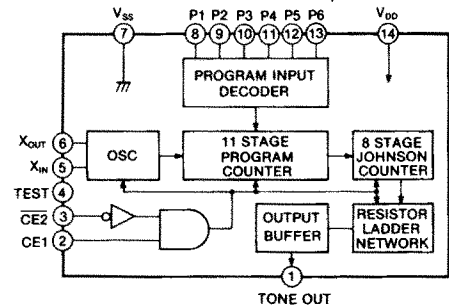

**S-8054ALB**  
(RESET)

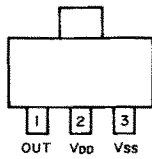

**SN74LS90P, M74LS90P**  
(DECADE COUNTERS)

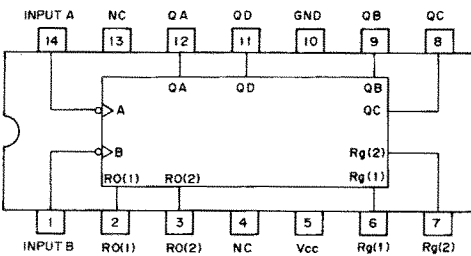

**SC-1094**  
(ROM)

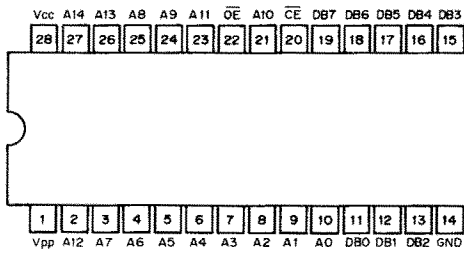

**SN74S10NS**  
(TRIPLE 3-INPUT NAND GATE)

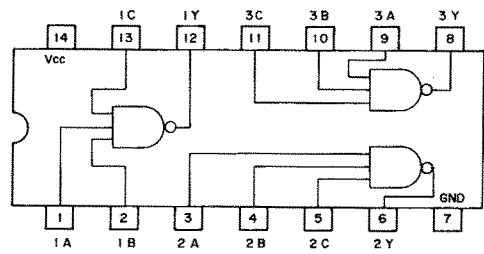

**SN74LS07NS**  
(HEX INVERTER)

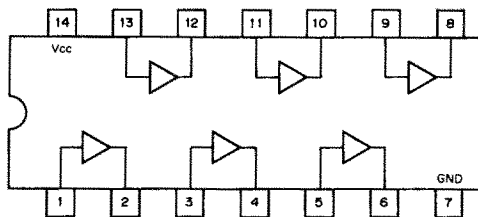

**SN74S132N**  
(QUAD 2-INPUT NAND SCHMITT TRIGGER)

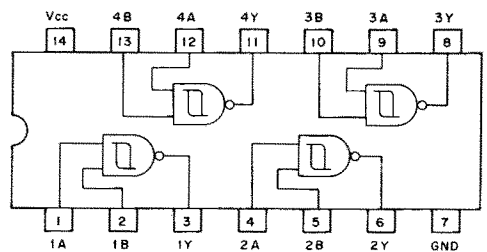



**SN74S112N/NS**  
(DUAL JK FLIP FLOP)

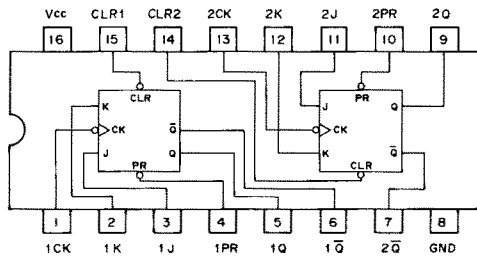

**TC35094P**  
(A/D CONVERTER)

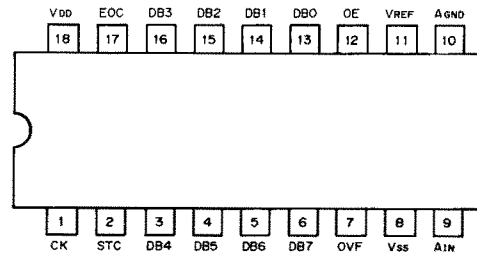

**TA78L005AP**  
(3-TERMINAL 5V REGULATOR)

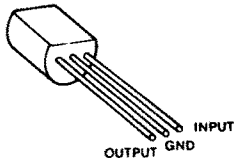

**TC74HC00P, SN74S00N**  
(QUAD 2-INPUT NAND GATE)

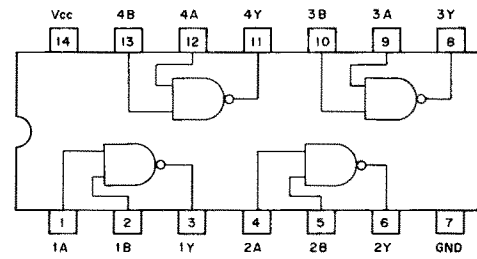

**TC74HCT374F**  
(DUAL D-TYPE FLIP FLOP)

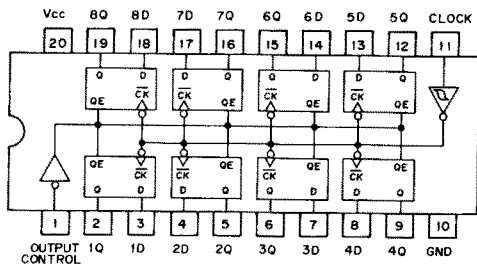

**TC9181P**  
(PROGRAM DIVIDER)

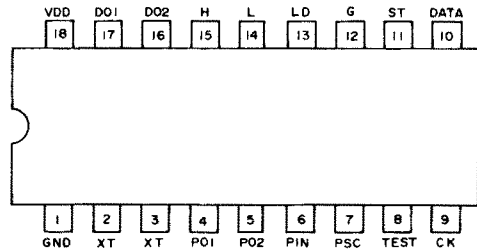

**TD6109P**  
(PRESCALER)

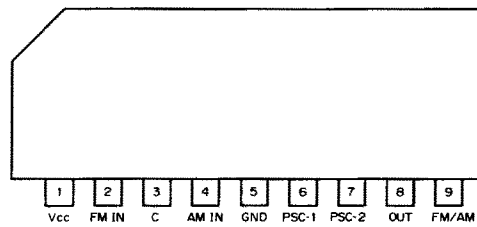

**TD6128P**  
(8 BIT A/D CONVERTER)

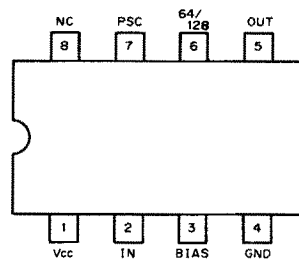

**μPC1037H**  
(DOUBLE BALANCED MIXER)

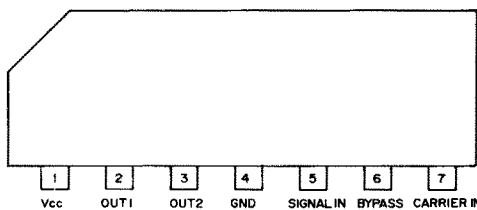

**μPC1042C**  
(PULSE CONTROL)

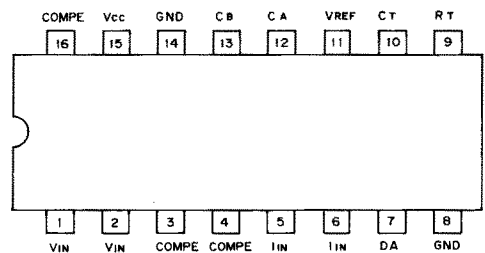

**μPC1241H**  
(AUDIO POWER AMPLIFIER)

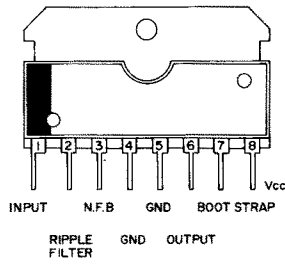

**μPD4001BC**  
(QUAD 2-INPUT POSITIVE NOR GATE)

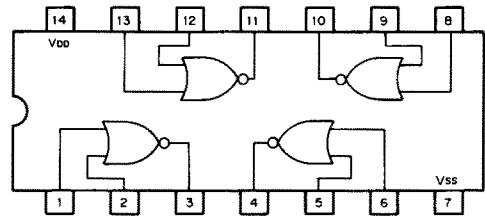

**μPD4011BC, TC4011BP**  
(QUAD 2-INPUT NAND GATE)

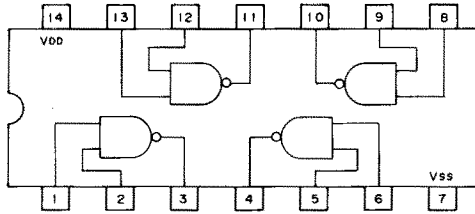

**μPD4013BC**  
(DUAL D-TYPE FLIP FLOP)

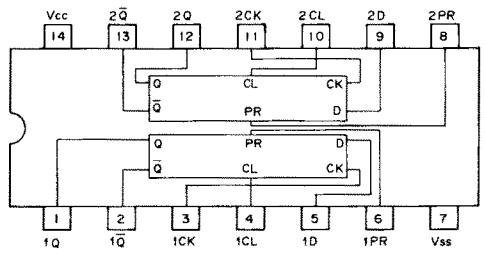

**μPD4024BC**  
(7-STAGE BINARY COUNTER)

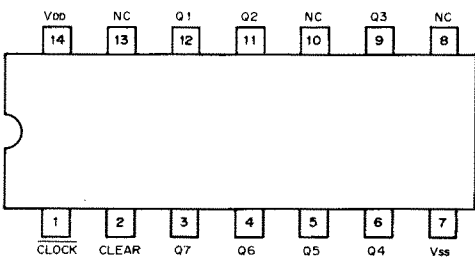

**μPD4028BC**  
(BCD TO DECIMAL DECODER)

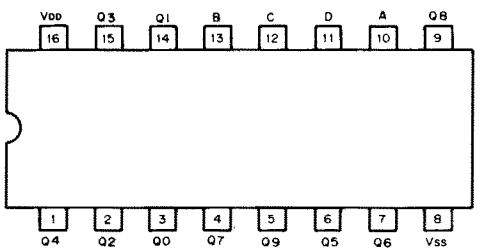

**μPD4052BC**  
(4-CHANNEL ANALOG MULTIPLEXER)

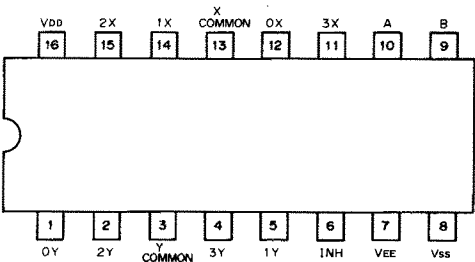

**μPD4066BC**  
(QUAD BILATERAL SWITCHING)

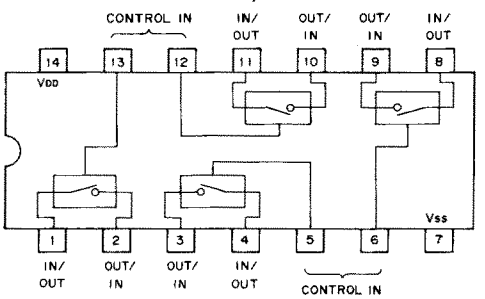

**μPD4071BC**  
(QUAD 2-INPUT OR GATE)

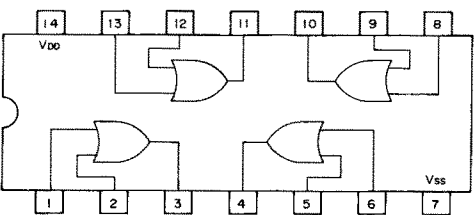

**μPD4364C**  
(RAM)

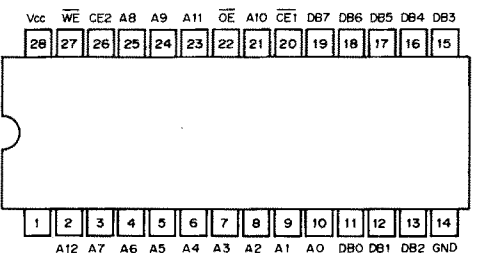

**μPD4520BC**  
(DUAL BINARY UP COUNTER)

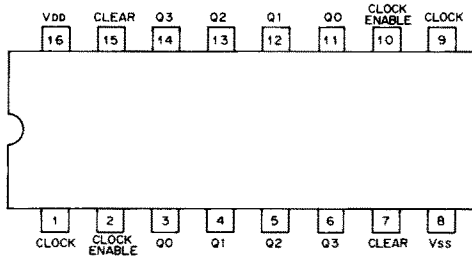

**μPD4528BC**  
(DUAL MONOSTABLE MULTIVIBRATOR)

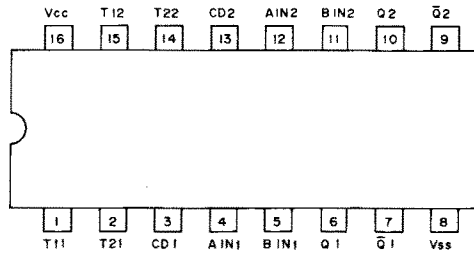

**μPD71055C**  
(I/O EXPANDER)

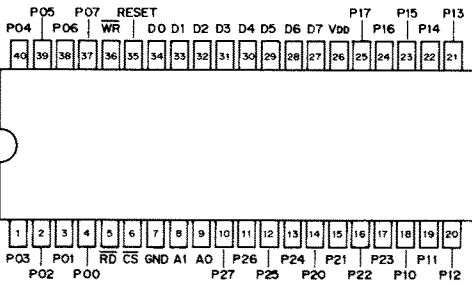

**μPD74HC244C**  
(OCTAL 3-STATE BUS DRIVER)

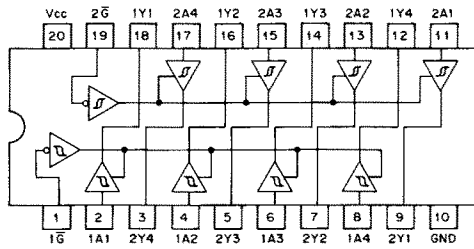

**μPD74HC32C**  
(QUAD 2-INPUT OR GATE)

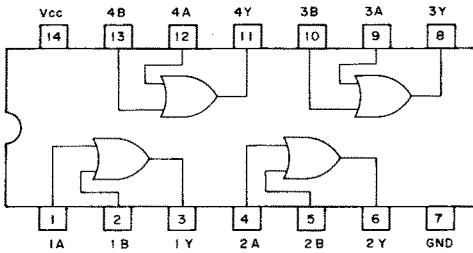

**μPD74HC367C**  
(HEX 3-STATE BUS DRIVER)

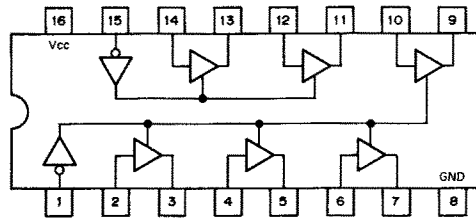

**μPD74HC42C**  
(BCD TO DECIMAL DECODER)

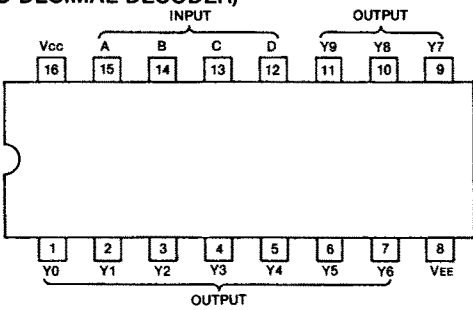

**μPD75104CW-117**  
(CPU)

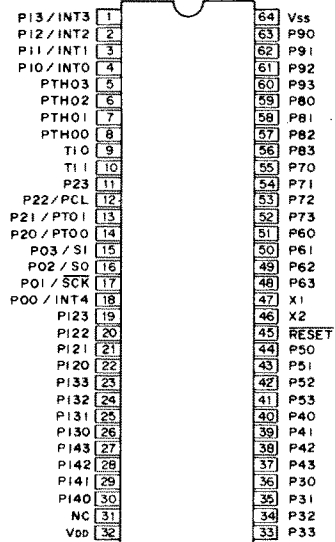

**μPD7584CS-031**  
(CPU)

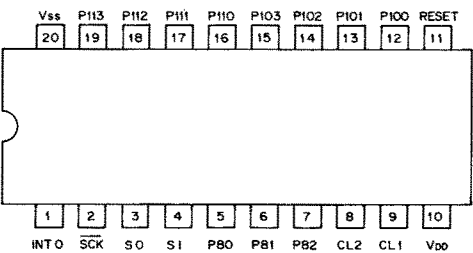



# SECTION 9 VOLTAGE DIAGRAMS

## 9-1 FRONT UNIT

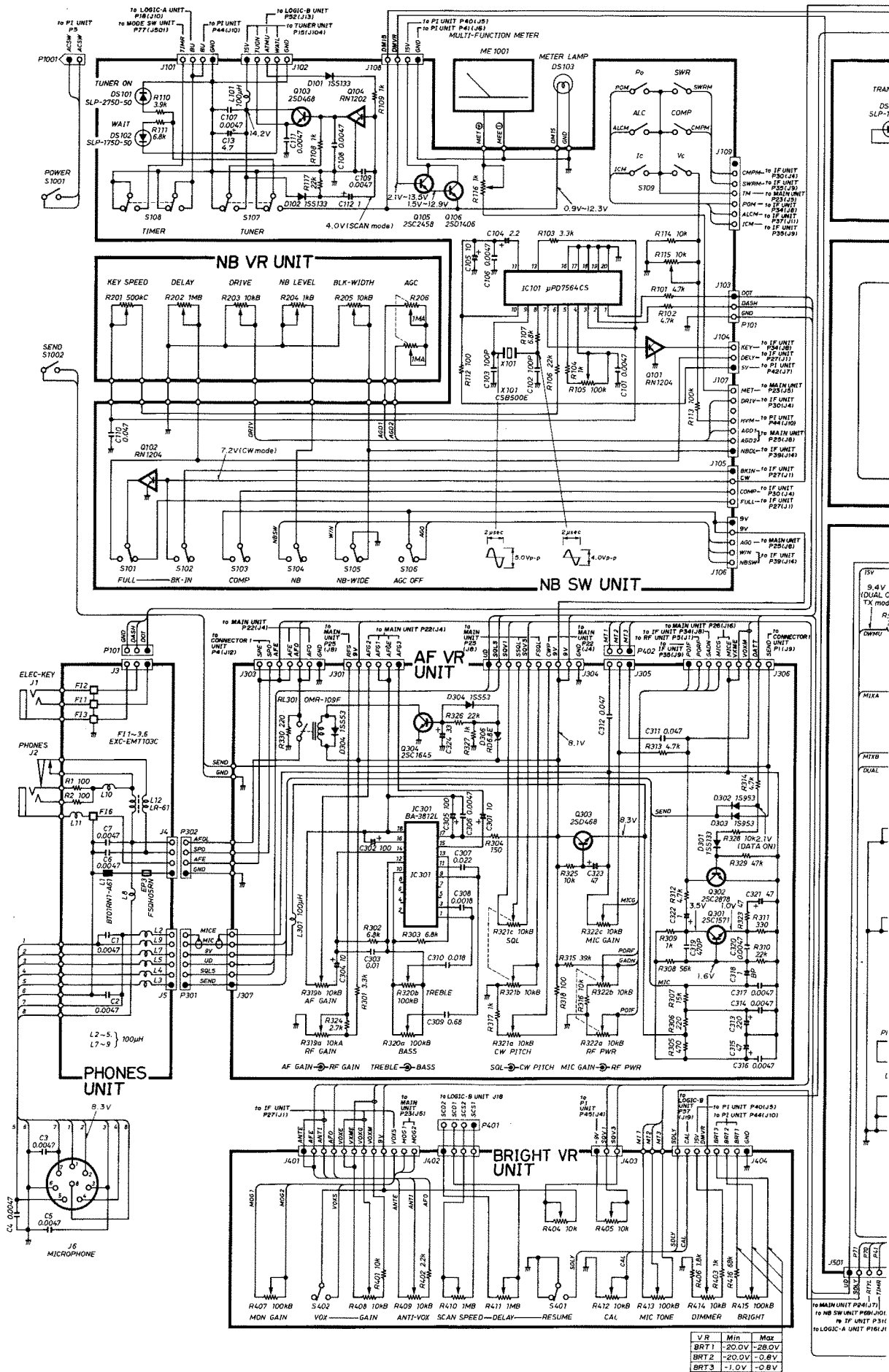

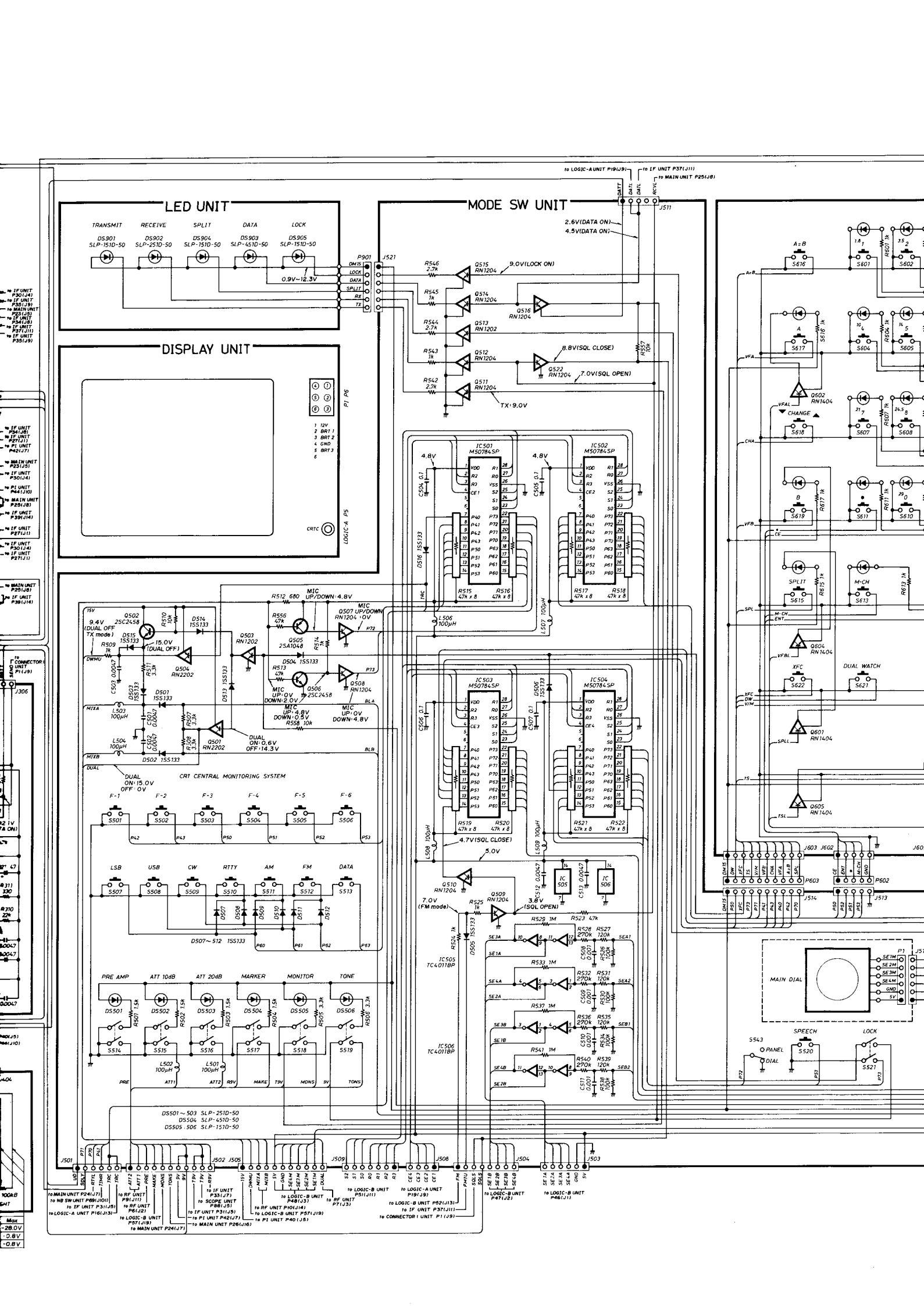

### LED UNIT

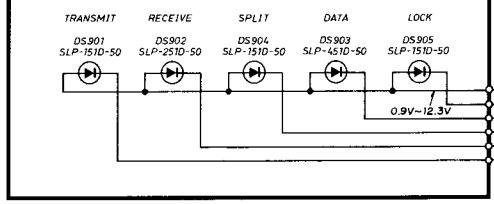

### DISPLAY UNIT

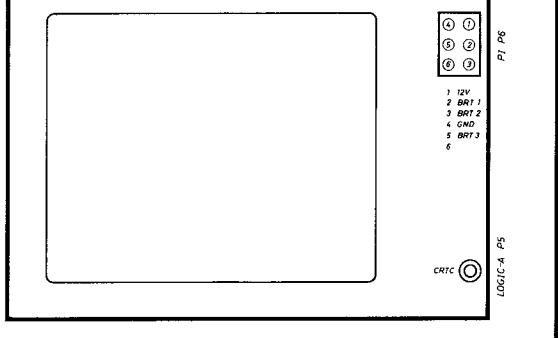

### MODE SW UNIT

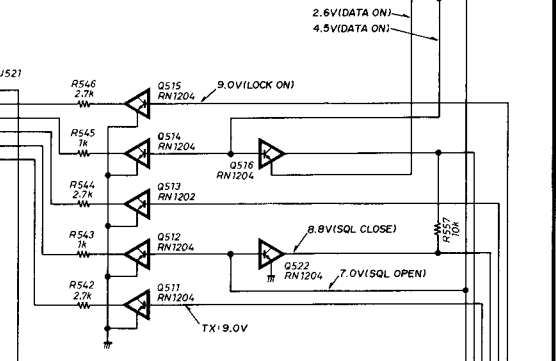

### CRT CENTRAL MONITORING SYSTEM

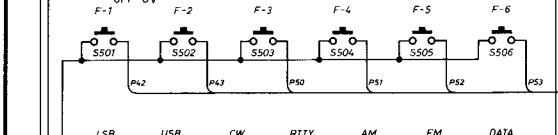

### LSB USB CW RTTY AM FM DATA

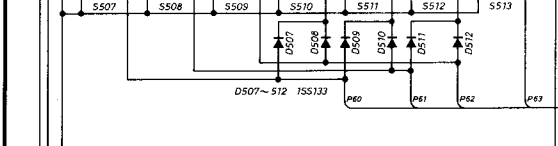

### PRE AMP ATT 10dB ATT 20dB MARKER MONITOR TONE

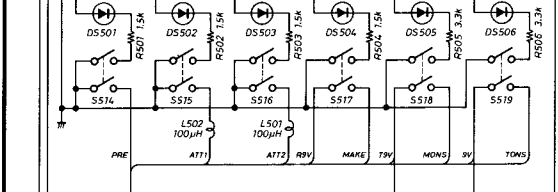

DS501-503 SLP-2510-50  
DS504 SLP-4510-50  
DS505-506 SLP-1510-50

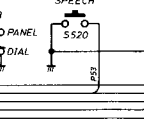
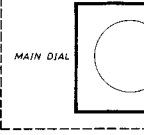
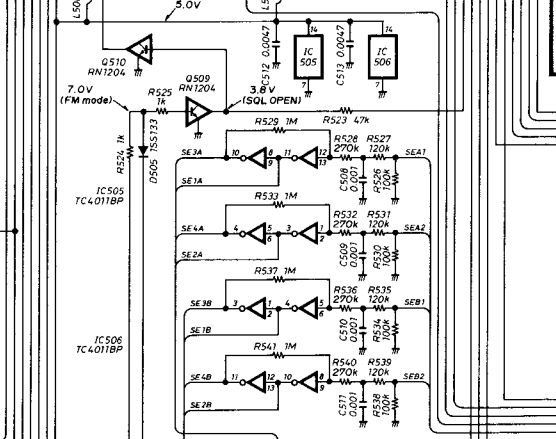
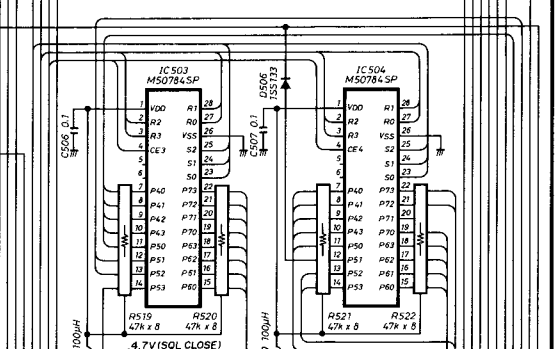
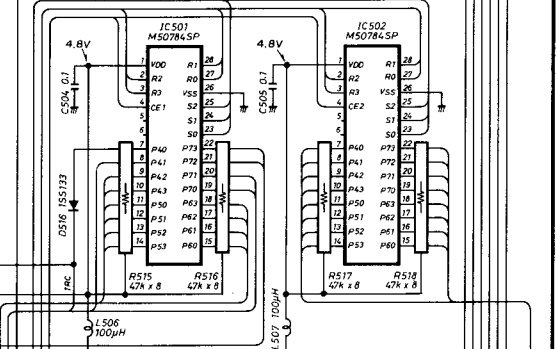

- Max
- 28.0V
- 3.8V
- 0.8V

IF UNIT P50(J14)  
IF UNIT P51(J15)  
IF UNIT P52(J16)  
IF UNIT P53(J17)  
IF UNIT P54(J18)  
IF UNIT P55(J19)  
IF UNIT P56(J20)  
IF UNIT P57(J21)  
IF UNIT P58(J22)  
IF UNIT P59(J23)  
IF UNIT P60(J24)  
IF UNIT P61(J25)  
IF UNIT P62(J26)  
IF UNIT P63(J27)  
IF UNIT P64(J28)  
IF UNIT P65(J29)  
IF UNIT P66(J30)  
IF UNIT P67(J31)  
IF UNIT P68(J32)  
IF UNIT P69(J33)  
IF UNIT P70(J34)  
IF UNIT P71(J35)  
IF UNIT P72(J36)  
IF UNIT P73(J37)  
IF UNIT P74(J38)  
IF UNIT P75(J39)  
IF UNIT P76(J40)  
IF UNIT P77(J41)  
IF UNIT P78(J42)  
IF UNIT P79(J43)  
IF UNIT P80(J44)  
IF UNIT P81(J45)  
IF UNIT P82(J46)  
IF UNIT P83(J47)  
IF UNIT P84(J48)  
IF UNIT P85(J49)  
IF UNIT P86(J50)  
IF UNIT P87(J51)  
IF UNIT P88(J52)  
IF UNIT P89(J53)  
IF UNIT P90(J54)  
IF UNIT P91(J55)  
IF UNIT P92(J56)  
IF UNIT P93(J57)  
IF UNIT P94(J58)  
IF UNIT P95(J59)  
IF UNIT P96(J60)  
IF UNIT P97(J61)  
IF UNIT P98(J62)  
IF UNIT P99(J63)  
IF UNIT P100(J64)  
IF UNIT P101(J65)  
IF UNIT P102(J66)  
IF UNIT P103(J67)  
IF UNIT P104(J68)  
IF UNIT P105(J69)  
IF UNIT P106(J70)  
IF UNIT P107(J71)  
IF UNIT P108(J72)  
IF UNIT P109(J73)  
IF UNIT P110(J74)  
IF UNIT P111(J75)  
IF UNIT P112(J76)  
IF UNIT P113(J77)  
IF UNIT P114(J78)  
IF UNIT P115(J79)  
IF UNIT P116(J80)  
IF UNIT P117(J81)  
IF UNIT P118(J82)  
IF UNIT P119(J83)  
IF UNIT P120(J84)  
IF UNIT P121(J85)  
IF UNIT P122(J86)  
IF UNIT P123(J87)  
IF UNIT P124(J88)  
IF UNIT P125(J89)  
IF UNIT P126(J90)  
IF UNIT P127(J91)  
IF UNIT P128(J92)  
IF UNIT P129(J93)  
IF UNIT P130(J94)  
IF UNIT P131(J95)  
IF UNIT P132(J96)  
IF UNIT P133(J97)  
IF UNIT P134(J98)  
IF UNIT P135(J99)  
IF UNIT P136(J100)  
IF UNIT P137(J101)  
IF UNIT P138(J102)  
IF UNIT P139(J103)  
IF UNIT P140(J104)  
IF UNIT P141(J105)  
IF UNIT P142(J106)  
IF UNIT P143(J107)  
IF UNIT P144(J108)  
IF UNIT P145(J109)  
IF UNIT P146(J110)  
IF UNIT P147(J111)  
IF UNIT P148(J112)  
IF UNIT P149(J113)  
IF UNIT P150(J114)  
IF UNIT P151(J115)  
IF UNIT P152(J116)  
IF UNIT P153(J117)  
IF UNIT P154(J118)  
IF UNIT P155(J119)  
IF UNIT P156(J120)  
IF UNIT P157(J121)  
IF UNIT P158(J122)  
IF UNIT P159(J123)  
IF UNIT P160(J124)  
IF UNIT P161(J125)  
IF UNIT P162(J126)  
IF UNIT P163(J127)  
IF UNIT P164(J128)  
IF UNIT P165(J129)  
IF UNIT P166(J130)  
IF UNIT P167(J131)  
IF UNIT P168(J132)  
IF UNIT P169(J133)  
IF UNIT P170(J134)  
IF UNIT P171(J135)  
IF UNIT P172(J136)  
IF UNIT P173(J137)  
IF UNIT P174(J138)  
IF UNIT P175(J139)  
IF UNIT P176(J140)  
IF UNIT P177(J141)  
IF UNIT P178(J142)  
IF UNIT P179(J143)  
IF UNIT P180(J144)  
IF UNIT P181(J145)  
IF UNIT P182(J146)  
IF UNIT P183(J147)  
IF UNIT P184(J148)  
IF UNIT P185(J149)  
IF UNIT P186(J150)  
IF UNIT P187(J151)  
IF UNIT P188(J152)  
IF UNIT P189(J153)  
IF UNIT P190(J154)  
IF UNIT P191(J155)  
IF UNIT P192(J156)  
IF UNIT P193(J157)  
IF UNIT P194(J158)  
IF UNIT P195(J159)  
IF UNIT P196(J160)  
IF UNIT P197(J161)  
IF UNIT P198(J162)  
IF UNIT P199(J163)  
IF UNIT P200(J164)  
IF UNIT P201(J165)  
IF UNIT P202(J166)  
IF UNIT P203(J167)  
IF UNIT P204(J168)  
IF UNIT P205(J169)  
IF UNIT P206(J170)  
IF UNIT P207(J171)  
IF UNIT P208(J172)  
IF UNIT P209(J173)  
IF UNIT P210(J174)  
IF UNIT P211(J175)  
IF UNIT P212(J176)  
IF UNIT P213(J177)  
IF UNIT P214(J178)  
IF UNIT P215(J179)  
IF UNIT P216(J180)  
IF UNIT P217(J181)  
IF UNIT P218(J182)  
IF UNIT P219(J183)  
IF UNIT P220(J184)  
IF UNIT P221(J185)  
IF UNIT P222(J186)  
IF UNIT P223(J187)  
IF UNIT P224(J188)  
IF UNIT P225(J189)  
IF UNIT P226(J190)  
IF UNIT P227(J191)  
IF UNIT P228(J192)  
IF UNIT P229(J193)  
IF UNIT P230(J194)  
IF UNIT P231(J195)  
IF UNIT P232(J196)  
IF UNIT P233(J197)  
IF UNIT P234(J198)  
IF UNIT P235(J199)  
IF UNIT P236(J200)  
IF UNIT P237(J201)  
IF UNIT P238(J202)  
IF UNIT P239(J203)  
IF UNIT P240(J204)  
IF UNIT P241(J205)  
IF UNIT P242(J206)  
IF UNIT P243(J207)  
IF UNIT P244(J208)  
IF UNIT P245(J209)  
IF UNIT P246(J210)  
IF UNIT P247(J211)  
IF UNIT P248(J212)  
IF UNIT P249(J213)  
IF UNIT P250(J214)  
IF UNIT P251(J215)  
IF UNIT P252(J216)  
IF UNIT P253(J217)  
IF UNIT P254(J218)  
IF UNIT P255(J219)  
IF UNIT P256(J220)  
IF UNIT P257(J221)  
IF UNIT P258(J222)  
IF UNIT P259(J223)  
IF UNIT P260(J224)  
IF UNIT P261(J225)  
IF UNIT P262(J226)  
IF UNIT P263(J227)  
IF UNIT P264(J228)  
IF UNIT P265(J229)  
IF UNIT P266(J230)  
IF UNIT P267(J231)  
IF UNIT P268(J232)  
IF UNIT P269(J233)  
IF UNIT P270(J234)  
IF UNIT P271(J235)  
IF UNIT P272(J236)  
IF UNIT P273(J237)  
IF UNIT P274(J238)  
IF UNIT P275(J239)  
IF UNIT P276(J240)  
IF UNIT P277(J241)  
IF UNIT P278(J242)  
IF UNIT P279(J243)  
IF UNIT P280(J244)  
IF UNIT P281(J245)  
IF UNIT P282(J246)  
IF UNIT P283(J247)  
IF UNIT P284(J248)  
IF UNIT P285(J249)  
IF UNIT P286(J250)  
IF UNIT P287(J251)  
IF UNIT P288(J252)  
IF UNIT P289(J253)  
IF UNIT P290(J254)  
IF UNIT P291(J255)  
IF UNIT P292(J256)  
IF UNIT P293(J257)  
IF UNIT P294(J258)  
IF UNIT P295(J259)  
IF UNIT P296(J260)  
IF UNIT P297(J261)  
IF UNIT P298(J262)  
IF UNIT P299(J263)  
IF UNIT P300(J264)  
IF UNIT P301(J265)  
IF UNIT P302(J266)  
IF UNIT P303(J267)  
IF UNIT P304(J268)  
IF UNIT P305(J269)  
IF UNIT P306(J270)  
IF UNIT P307(J271)  
IF UNIT P308(J272)  
IF UNIT P309(J273)  
IF UNIT P310(J274)  
IF UNIT P311(J275)  
IF UNIT P312(J276)  
IF UNIT P313(J277)  
IF UNIT P314(J278)  
IF UNIT P315(J279)  
IF UNIT P316(J280)  
IF UNIT P317(J281)  
IF UNIT P318(J282)  
IF UNIT P319(J283)  
IF UNIT P320(J284)  
IF UNIT P321(J285)  
IF UNIT P322(J286)  
IF UNIT P323(J287)  
IF UNIT P324(J288)  
IF UNIT P325(J289)  
IF UNIT P326(J290)  
IF UNIT P327(J291)  
IF UNIT P328(J292)  
IF UNIT P329(J293)  
IF UNIT P330(J294)  
IF UNIT P331(J295)  
IF UNIT P332(J296)  
IF UNIT P333(J297)  
IF UNIT P334(J298)  
IF UNIT P335(J299)  
IF UNIT P336(J300)  
IF UNIT P337(J301)  
IF UNIT P338(J302)  
IF UNIT P339(J303)  
IF UNIT P340(J304)  
IF UNIT P341(J305)  
IF UNIT P342(J306)  
IF UNIT P343(J307)  
IF UNIT P344(J308)  
IF UNIT P345(J309)  
IF UNIT P346(J310)  
IF UNIT P347(J311)  
IF UNIT P348(J312)  
IF UNIT P349(J313)  
IF UNIT P350(J314)  
IF UNIT P351(J315)  
IF UNIT P352(J316)  
IF UNIT P353(J317)  
IF UNIT P354(J318)  
IF UNIT P355(J319)  
IF UNIT P356(J320)  
IF UNIT P357(J321)  
IF UNIT P358(J322)  
IF UNIT P359(J323)  
IF UNIT P360(J324)  
IF UNIT P361(J325)  
IF UNIT P362(J326)  
IF UNIT P363(J327)  
IF UNIT P364(J328)  
IF UNIT P365(J329)  
IF UNIT P366(J330)  
IF UNIT P367(J331)  
IF UNIT P368(J332)  
IF UNIT P369(J333)  
IF UNIT P370(J334)  
IF UNIT P371(J335)  
IF UNIT P372(J336)  
IF UNIT P373(J337)  
IF UNIT P374(J338)  
IF UNIT P375(J339)  
IF UNIT P376(J340)  
IF UNIT P377(J341)  
IF UNIT P378(J342)  
IF UNIT P379(J343)  
IF UNIT P380(J344)  
IF UNIT P381(J345)  
IF UNIT P382(J346)  
IF UNIT P383(J347)  
IF UNIT P384(J348)  
IF UNIT P385(J349)  
IF UNIT P386(J350)  
IF UNIT P387(J351)  
IF UNIT P388(J352)  
IF UNIT P389(J353)  
IF UNIT P390(J354)  
IF UNIT P391(J355)  
IF UNIT P392(J356)  
IF UNIT P393(J357)  
IF UNIT P394(J358)  
IF UNIT P395(J359)  
IF UNIT P396(J360)  
IF UNIT P397(J361)  
IF UNIT P398(J362)  
IF UNIT P399(J363)  
IF UNIT P400(J364)  
IF UNIT P401(J365)  
IF UNIT P402(J366)  
IF UNIT P403(J367)  
IF UNIT P404(J368)  
IF UNIT P405(J369)  
IF UNIT P406(J370)  
IF UNIT P407(J371)  
IF UNIT P408(J372)  
IF UNIT P409(J373)  
IF UNIT P410(J374)  
IF UNIT P411(J375)  
IF UNIT P412(J376)  
IF UNIT P413(J377)  
IF UNIT P414(J378)  
IF UNIT P415(J379)  
IF UNIT P416(J380)  
IF UNIT P417(J381)  
IF UNIT P418(J382)  
IF UNIT P419(J383)  
IF UNIT P420(J384)  
IF UNIT P421(J385)  
IF UNIT P422(J386)  
IF UNIT P423(J387)  
IF UNIT P424(J388)  
IF UNIT P425(J389)  
IF UNIT P426(J390)  
IF UNIT P427(J391)  
IF UNIT P428(J392)  
IF UNIT P429(J393)  
IF UNIT P430(J394)  
IF UNIT P431(J395)  
IF UNIT P432(J396)  
IF UNIT P433(J397)  
IF UNIT P434(J398)  
IF UNIT P435(J399)  
IF UNIT P436(J400)  
IF UNIT P437(J401)  
IF UNIT P438(J402)  
IF UNIT P439(J403)  
IF UNIT P440(J404)  
IF UNIT P441(J405)  
IF UNIT P442(J406)  
IF UNIT P443(J407)  
IF UNIT P444(J408)  
IF UNIT P445(J409)  
IF UNIT P446(J410)  
IF UNIT P447(J411)  
IF UNIT P448(J412)  
IF UNIT P449(J413)  
IF UNIT P450(J414)  
IF UNIT P451(J415)  
IF UNIT P452(J416)  
IF UNIT P453(J417)  
IF UNIT P454(J418)  
IF UNIT P455(J419)  
IF UNIT P456(J420)  
IF UNIT P457(J421)  
IF UNIT P458(J422)  
IF UNIT P459(J423)  
IF UNIT P460(J424)  
IF UNIT P461(J425)  
IF UNIT P462(J426)  
IF UNIT P463(J427)  
IF UNIT P464(J428)  
IF UNIT P465(J429)  
IF UNIT P466(J430)  
IF UNIT P467(J431)  
IF UNIT P468(J432)  
IF UNIT P469(J433)  
IF UNIT P470(J434)  
IF UNIT P471(J435)  
IF UNIT P472(J436)  
IF UNIT P473(J437)  
IF UNIT P474(J438)  
IF UNIT P475(J439)  
IF UNIT P476(J440)  
IF UNIT P477(J441)  
IF UNIT P478(J442)  
IF UNIT P479(J443)  
IF UNIT P480(J444)  
IF UNIT P481(J445)  
IF UNIT P482(J446)  
IF UNIT P483(J447)  
IF UNIT P484(J448)  
IF UNIT P485(J449)  
IF UNIT P486(J450)  
IF UNIT P487(J451)  
IF UNIT P488(J452)  
IF UNIT P489(J453)  
IF UNIT P490(J454)  
IF UNIT P491(J455)  
IF UNIT P492(J456)  
IF UNIT P493(J457)  
IF UNIT P494(J458)  
IF UNIT P495(J459)  
IF UNIT P496(J460)  
IF UNIT P497(J461)  
IF UNIT P498(J462)  
IF UNIT P499(J463)  
IF UNIT P500(J464)  
IF UNIT P501(J465)  
IF UNIT P502(J466)  
IF UNIT P503(J467)  
IF UNIT P504(J468)  
IF UNIT P505(J469)  
IF UNIT P506(J470)  
IF UNIT P507(J471)  
IF UNIT P508(J472)  
IF UNIT P509(J473)  
IF UNIT P510(J474)  
IF UNIT P511(J475)  
IF UNIT P512(J476)  
IF UNIT P513(J477)  
IF UNIT P514(J478)  
IF UNIT P515(J479)  
IF UNIT P516(J480)  
IF UNIT P517(J481)  
IF UNIT P518(J482)  
IF UNIT P519(J483)  
IF UNIT P520(J484)  
IF UNIT P521(J485)  
IF UNIT P522(J486)  
IF UNIT P523(J487)  
IF UNIT P524(J488)  
IF UNIT P525(J489)  
IF UNIT P526(J490)  
IF UNIT P527(J491)  
IF UNIT P528(J492)  
IF UNIT P529(J493)  
IF UNIT P530(J494)  
IF UNIT P531(J495)  
IF UNIT P532(J496)  
IF UNIT P533(J497)  
IF UNIT P534(J498)  
IF UNIT P535(J499)  
IF UNIT P536(J500)  
IF UNIT P537(J501)  
IF UNIT P538(J502)  
IF UNIT P539(J503)  
IF UNIT P540(J504)  
IF UNIT P541(J505)  
IF UNIT P542(J506)  
IF UNIT P543(J507)  
IF UNIT P544(J508)  
IF UNIT P545(J509)  
IF UNIT P546(J510)  
IF UNIT P547(J511)  
IF UNIT P548(J512)  
IF UNIT P549(J513)  
IF UNIT P550(J514)  
IF UNIT P551(J515)  
IF UNIT P552(J516)  
IF UNIT P553(J517)  
IF UNIT P554(J518)  
IF UNIT P555(J519)  
IF UNIT P556(J520)  
IF UNIT P557(J521)  
IF UNIT P558(J522)  
IF UNIT P559(J523)  
IF UNIT P560(J524)  
IF UNIT P561(J525)  
IF UNIT P562(J526)  
IF UNIT P563(J527)  
IF UNIT P564(J528)  
IF UNIT P565(J529)  
IF UNIT P566(J530)  
IF UNIT P567(J531)  
IF UNIT P568(J532)  
IF UNIT P569(J533)  
IF UNIT P570(J534)  
IF UNIT P571(J535)  
IF UNIT P572(J536)  
IF UNIT P573(J537)  
IF UNIT P574(J538)  
IF UNIT P575(J539)  
IF UNIT P576(J540)  
IF UNIT P577(J541)  
IF UNIT P578(J542)  
IF UNIT P579(J543)  
IF UNIT P580(J544)  
IF UNIT P581(J545)  
IF UNIT P582(J546)  
IF UNIT P583(J547)  
IF UNIT P584(J548)  
IF UNIT P585(J549)  
IF UNIT P586(J550)  
IF UNIT P587(J551)  
IF UNIT P588(J552)  
IF UNIT P589(J553)  
IF UNIT P590(J554)  
IF UNIT P591(J555)  
IF UNIT P592(J556)  
IF UNIT P593(J557)  
IF UNIT P594(J558)  
IF UNIT P595(J559)  
IF UNIT P596(J560)  
IF UNIT P597(J561)  
IF UNIT P598(J562)  
IF UNIT P599(J563)  
IF UNIT P600(J564)  
IF UNIT P601(J565)  
IF UNIT P602(J566)  
IF UNIT P603(J567)  
IF UNIT P604(J568)  
IF UNIT P605(J569)  
IF UNIT P606(J570)  
IF UNIT P607(J571)  
IF UNIT P608(J572)  
IF UNIT P609(J573)  
IF UNIT P610(J574)  
IF UNIT P611(J575)  
IF UNIT P612(J576)  
IF UNIT P613(J577)  
IF UNIT P614(J578)  
IF UNIT P615(J579)  
IF UNIT P616(J580)  
IF UNIT P617(J581)  
IF UNIT P618(J582)  
IF UNIT P619(J583)  
IF UNIT P620(J584)  
IF UNIT P621(J585)  
IF UNIT P622(J586)  
IF UNIT P623(J587)  
IF UNIT P624(J588)  
IF UNIT P625(J589)  
IF UNIT P626(J590)  
IF UNIT P627(J591)  
IF UNIT P628(J592)  
IF UNIT P629(J593)  
IF UNIT P630(J594)  
IF UNIT P631(J595)  
IF UNIT P632(J596)  
IF UNIT P633(J597)  
IF UNIT P634(J598)  
IF UNIT P635(J599)  
IF UNIT P636(J600)  
IF UNIT P637(J601)  
IF UNIT P638(J602)  
IF UNIT P639(J603)  
IF UNIT P640(J604)  
IF UNIT P641(J605)  
IF UNIT P642(J606)  
IF UNIT P643(J607)  
IF UNIT P644(J608)  
IF UNIT P645(J609)  
IF UNIT P646(J610)  
IF UNIT P647(J611)  
IF UNIT P648(J612)  
IF UNIT P649(J613)  
IF UNIT P650(J614)  
IF UNIT P651(J615)  
IF UNIT P652(J616)  
IF UNIT P653(J617)  
IF UNIT P654(J618)  
IF UNIT P655(J619)  
IF UNIT P656(J620)  
IF UNIT P657(J621)  
IF UNIT P658(J622)  
IF UNIT P659(J623)  
IF UNIT P660(J624)  
IF UNIT P661(J625)  
IF UNIT P662(J626)  
IF UNIT P663(J627)  
IF UNIT P664(J628)  
IF UNIT P665(J629)  
IF UNIT P666(J630)  
IF UNIT P667(J631)  
IF UNIT P668(J632)  
IF UNIT P669(J633)  
IF UNIT P670(J634)  
IF UNIT P671(J635)  
IF UNIT P672(J636)  
IF UNIT P673(J637)  
IF UNIT P674(J638)  
IF UNIT P675(J639)  
IF UNIT P676(J640)  
IF UNIT P677(J641)  
IF UNIT P678(J642)  
IF UNIT P679(J643)  
IF UNIT P680(J644)  
IF UNIT P681(J645)  
IF UNIT P682(J646)  
IF UNIT P683(J647)  
IF UNIT P684(J648)  
IF UNIT P685(J649)  
IF UNIT P686(J650)  
IF UNIT P687(J651)  
IF UNIT P688(J652)  
IF UNIT P689(J653)  
IF UNIT P690(J654)  
IF UNIT P691(J655)  
IF UNIT P692(J656)  
IF UNIT P693(J657)  
IF UNIT P694(J658)  
IF UNIT P695(J659)  
IF UNIT P696(J660)  
IF UNIT P697(J661)  
IF UNIT P698(J662)  
IF UNIT P699(J663)  
IF UNIT P700(J664)  
IF UNIT P701(J665)  
IF UNIT P702(J666)  
IF UNIT P703(J667)  
IF UNIT P704(J668)  
IF UNIT P705(J669)  
IF UNIT P706(J670)  
IF UNIT P707(J671)  
IF UNIT P708(J672)  
IF UNIT P709(J673)  
IF UNIT P710(J674)  
IF UNIT P711(J675)  
IF UNIT P712(J676)  
IF UNIT P713(J677)  
IF UNIT P714(J678)  
IF UNIT P715(J679)  
IF UNIT P716(J680)  
IF UNIT P717(J681)  
IF UNIT P718(J682)  
IF UNIT P719(J683)  
IF UNIT P720(J684)  
IF UNIT P721(J685)  
IF UNIT P722(J686)  
IF UNIT P723(J687)  
IF UNIT P724(J688)  
IF UNIT P725(J689)  
IF UNIT P726(J690)  
IF UNIT P727(J691)  
IF UNIT P728(J692)  
IF UNIT P729(J693)  
IF UNIT P730(J694)  
IF UNIT P731(J695)  
IF UNIT P732(J696)  
IF UNIT P733(J697)  
IF UNIT P734(J698)  
IF UNIT P735(J699)  
IF UNIT P736(J700)  
IF UNIT P737(J701)  
IF UNIT P738(J702)  
IF UNIT P739(J703)  
IF UNIT P740(J704)  
IF UNIT P741(J705)  
IF UNIT P742(J706)  
IF UNIT P743(J707)  
IF UNIT P744(J708)  
IF UNIT P745(J709)  
IF UNIT P746(J710)  
IF UNIT P747(J711)  
IF UNIT P748(J712)  
IF UNIT P749(J713)  
IF UNIT P750(J714)  
IF UNIT P751(J715)  
IF UNIT P752(J716)  
IF UNIT P753(J717)  
IF UNIT P754(J718)  
IF UNIT P755(J719)  
IF UNIT P756(J720)  
IF UNIT P757(J721)  
IF UNIT P758(J722)  
IF UNIT P759(J723)  
IF UNIT P760(J724)  
IF UNIT P761(J725)  
IF UNIT P762(J726)  
IF UNIT P763(J727)  
IF UNIT P764(J728)  
IF UNIT P765(J729)  
IF UNIT P766(J730)  
IF UNIT P767(J731)  
IF UNIT P768(J732)  
IF UNIT P769(J733)  
IF UNIT P770(J734)  
IF UNIT P771(J735)  
IF UNIT P772(J736)  
IF UNIT P773(J737)  
IF UNIT P774(J738)  
IF UNIT P775(J739)  
IF UNIT P776(J740)  
IF UNIT P777(J741)  
IF UNIT P778(J742)  
IF UNIT P779(J743)  
IF UNIT P780(J744)  
IF UNIT P781(J745)  
IF UNIT P782(J746)  
IF UNIT P783(J747)  
IF UNIT P784(J748)  
IF UNIT P785(J749)  
IF UNIT P786(J750)  
IF UNIT P787(J751)  
IF UNIT P788(J752)  
IF UNIT P789(J753)  
IF UNIT P790(J754)  
IF UNIT P791(J755)  
IF UNIT P792(J756)  
IF UNIT P793(J757)  
IF UNIT P794(J758)  
IF UNIT P795(J759)  
IF UNIT P796(J760)  
IF UNIT P797(J761)  
IF UNIT P798(J762)  
IF UNIT P799(J763)  
IF UNIT P800(J764)  
IF UNIT P801(J765)  
IF UNIT P802(J766)  
IF UNIT P803(J767)  
IF UNIT P804(J768)  
IF UNIT P805(J769)  
IF UNIT P806(J770)  
IF UNIT P807(J771)  
IF UNIT P808(J772)  
IF UNIT P809(J773)  
IF UNIT P810(J774)  
IF UNIT P811(J775)  
IF UNIT P812(J776)  
IF UNIT P813(J777)  
IF UNIT P814(J778)  
IF UNIT P815(J779)  
IF UNIT P816(J780)  
IF UNIT P817(J7

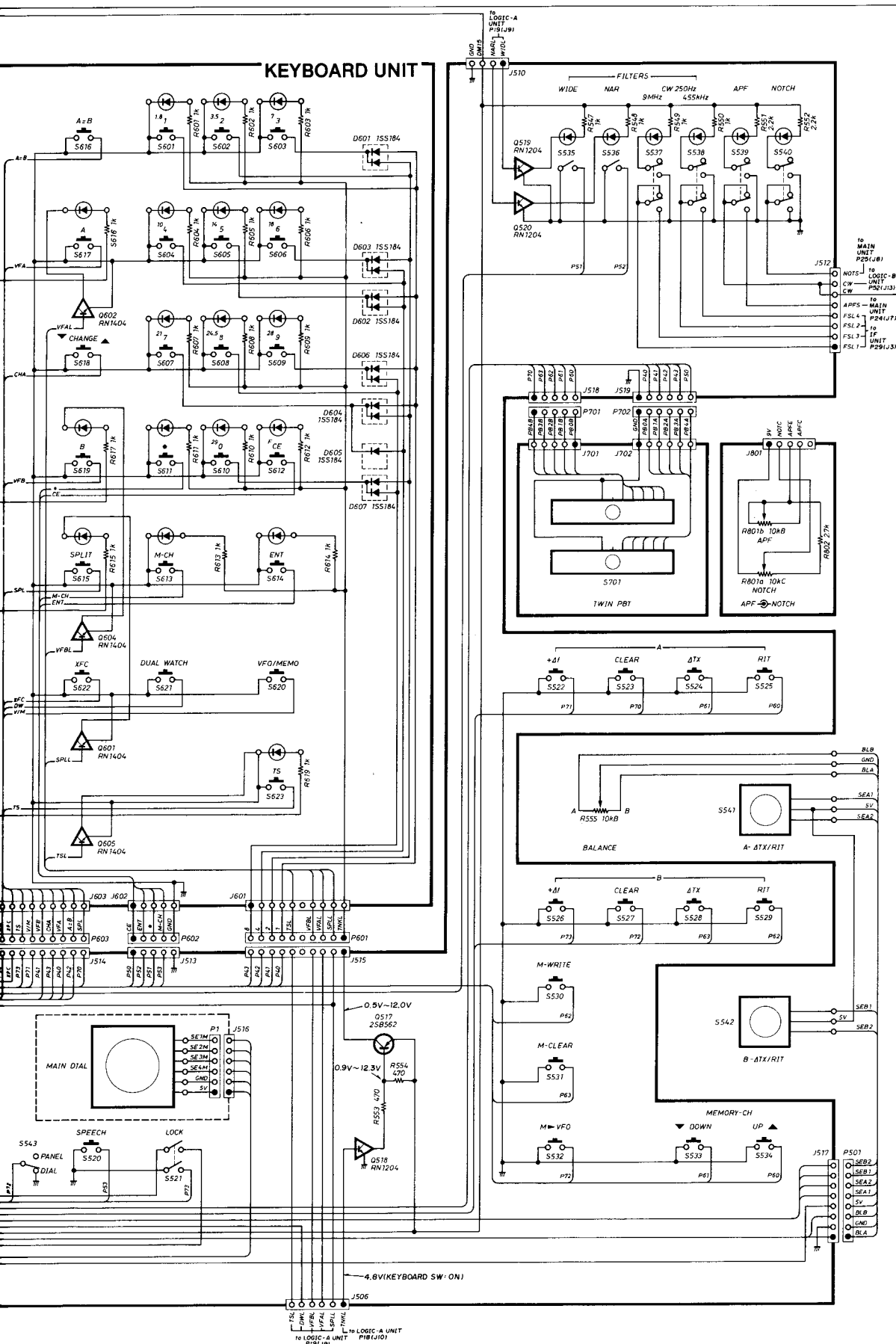





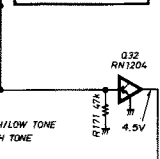
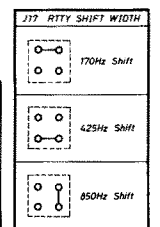
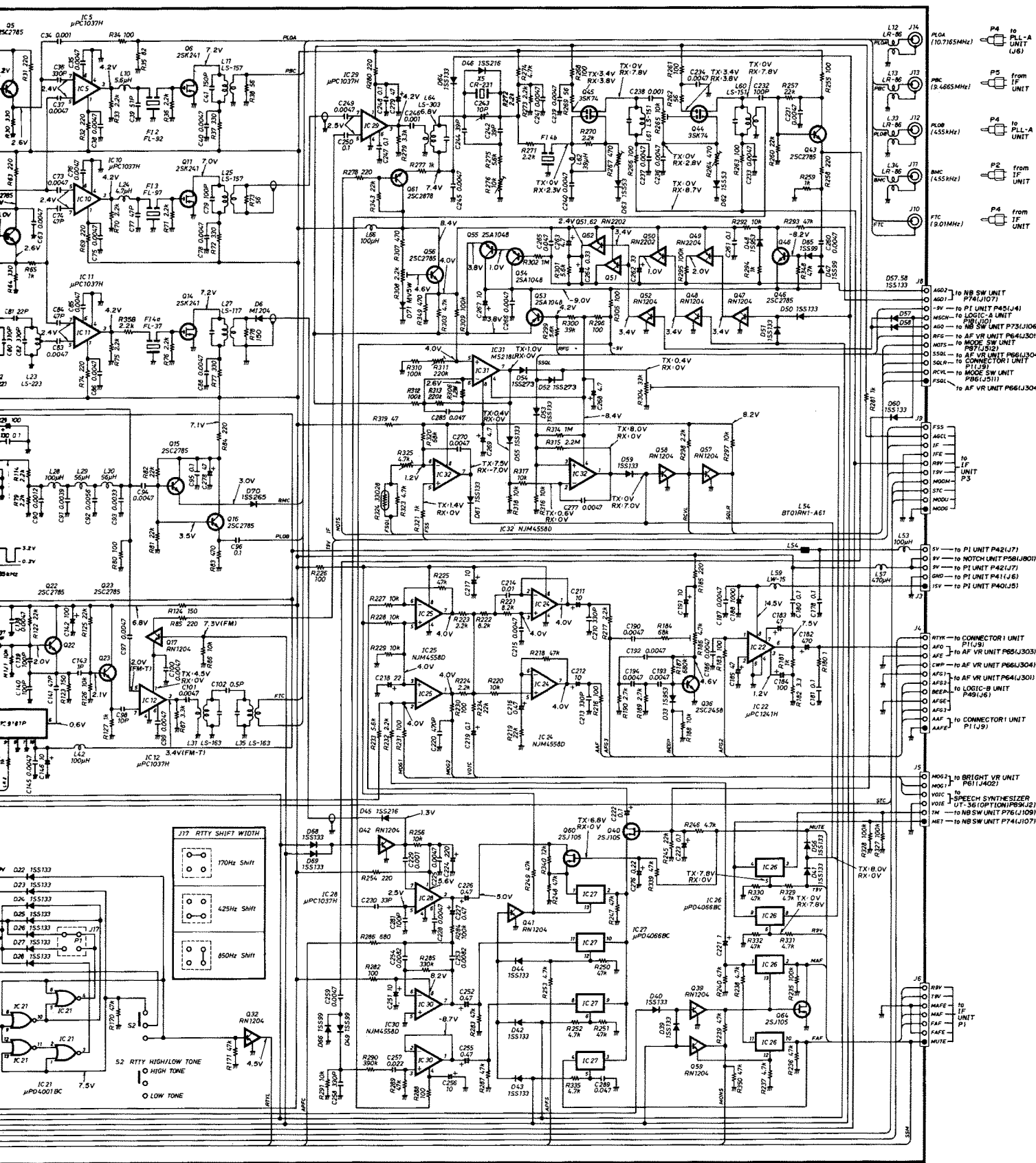

- P4 to P4 (10.7165MHz)
- P5 from P5 (1.455MHz)
- P4 to P4 (1.455MHz)
- P2 from P2 (1.455MHz)
- P4 from P4 (1.455MHz)
- A002 to NB SW UNIT P74(J107)
- A001 to P1 UNIT P45(J4)
- A000 to LOGIC-A UNIT P8(J101)
- A00 to NB SW UNIT P73(J106)
- A06 to AF VR UNIT P64(J304)
- A05 to MODE SW UNIT P87(J102)
- A04 to AF VR UNIT P66(J304)
- A03 to CONNECTOR 1 UNIT P11(J9)
- A02 to MODE SW UNIT P86(J511)
- A01 to AF VR UNIT P66(J304)
- A00 to P1 UNIT P42(J7)
- A00 to NOTCH UNIT P56(J301)
- A00 to P1 UNIT P42(J7)
- A00 to P1 UNIT P41(J6)
- A00 to P1 UNIT P40(J5)
- RTK to CONNECTOR 1 UNIT P11(J9)
- AFO to AF VR UNIT P65(J303)
- CWP to AF VR UNIT P66(J304)
- A07 to AF VR UNIT P64(J301)
- A06 to LOGIC-B UNIT P49(J6)
- A05 to CONNECTOR 1 UNIT P11(J9)
- A04 to BRIGHT VR UNIT P61(J402)
- A03 to SPEECH SYNTHESIZER UT-3610PT(W/PS4J2)
- A02 to NB SW UNIT P76(J109)
- A01 to NB SW UNIT P74(J107)

**M5218L**  
(LOW NOISE DUAL OPERATIONAL AMPLIFIER)

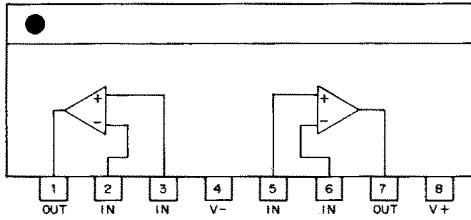

**M54459L**  
(1/20, 1/100 HIGH SPEED DIVIDER)

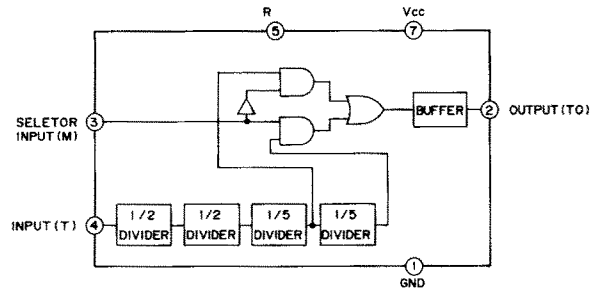

**M54562P**  
(DARLINGTON TRANSISTOR ARRAY)

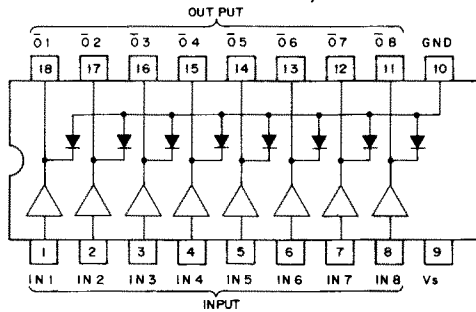

**MC145158P1**  
(SERIAL INPUT PLL FREQUENCY SYNTHESIZER)

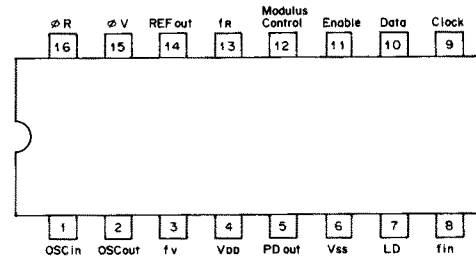

**MC3357P**  
(LOW POWER FM IF)

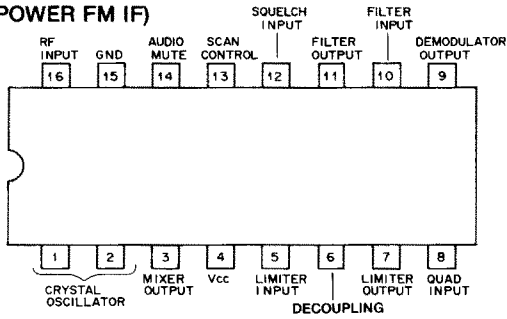

**ND487C1-3R, ND487C2-3R**  
(SCHOTTKY BARRIER DIODE QUAD)

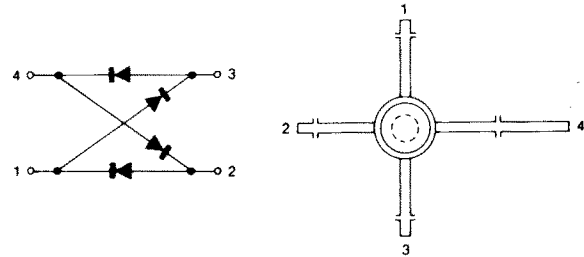

**NJM4558D/M, NJM4560DD**  
(DUAL OPERATIONAL AMPLIFIER)

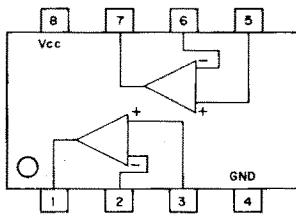

**NJM2204AD**  
(LOG DETECTOR)

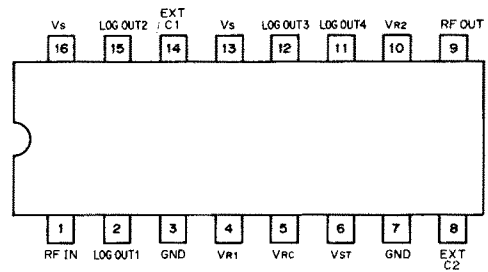

**NJM7805A**  
(3-TERMINAL 5 V REGULATOR)

**NJM7809A**  
(3-TERMINAL 9 V REGULATOR)

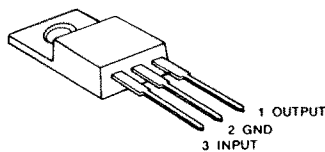

**NJM78L05A**  
(3-TERMINAL 5 V REGULATOR)

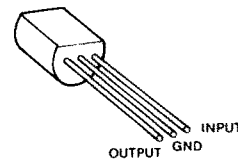





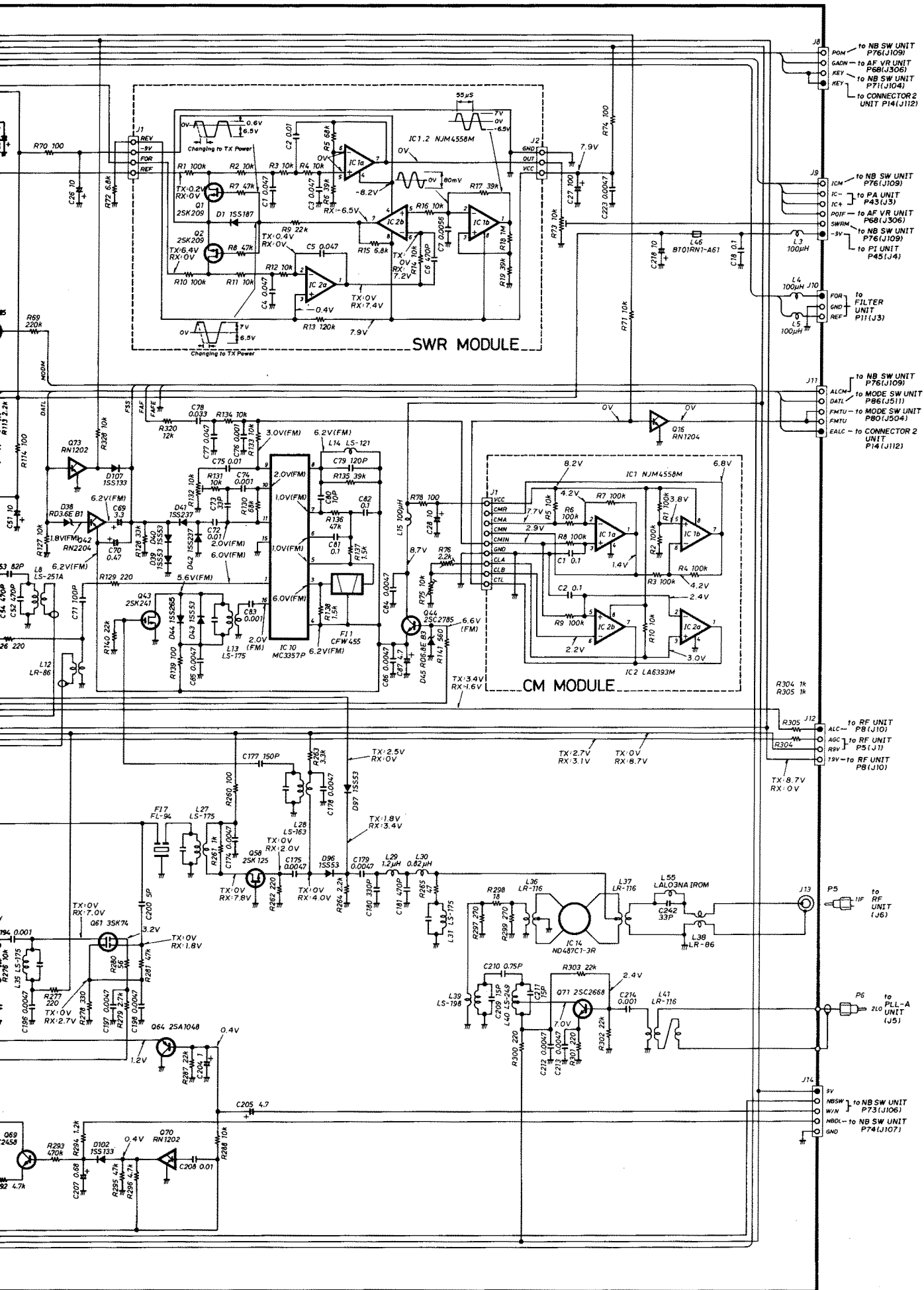

SWR MODULE

CM MODULE

# 9-4 RF UNIT

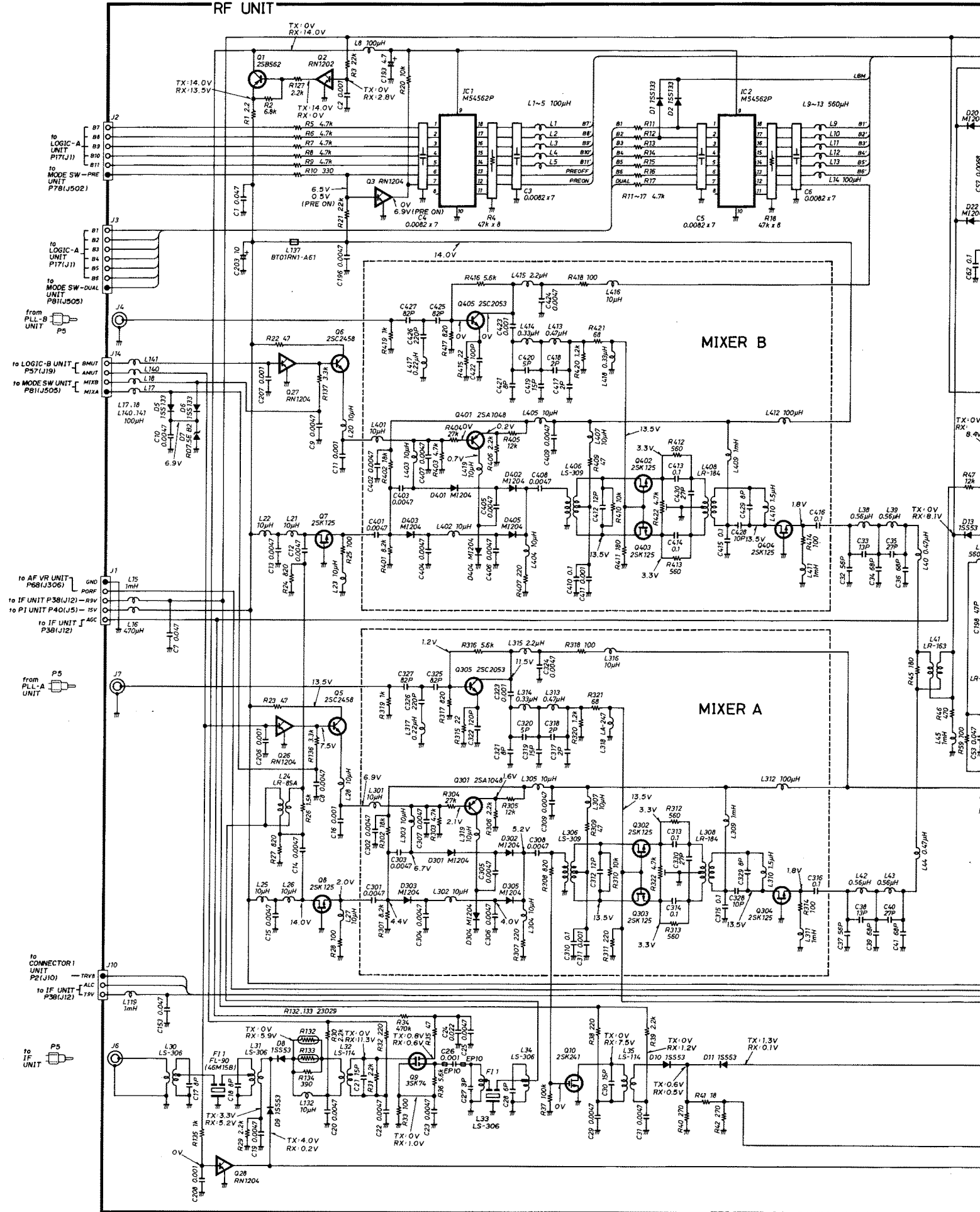







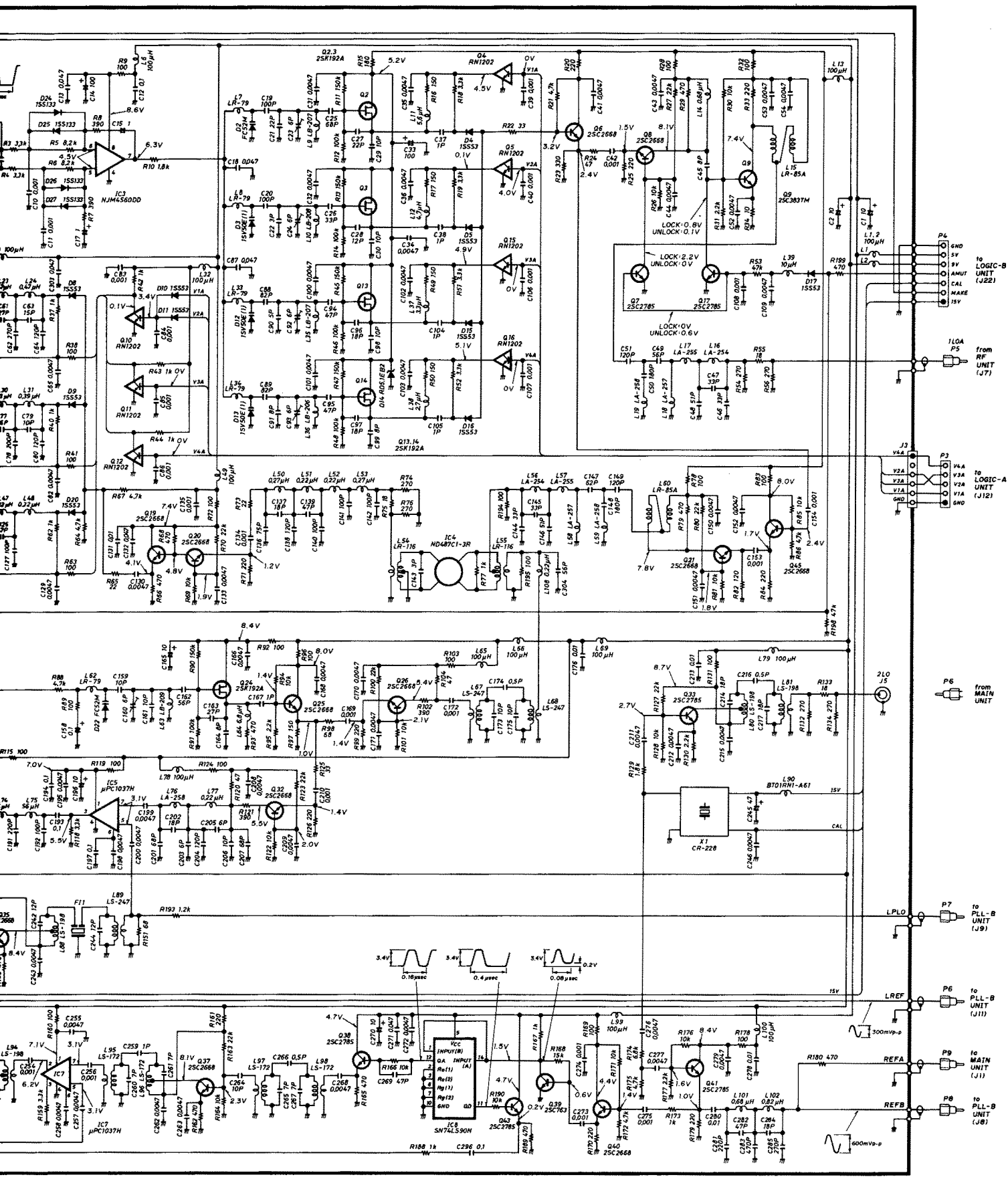





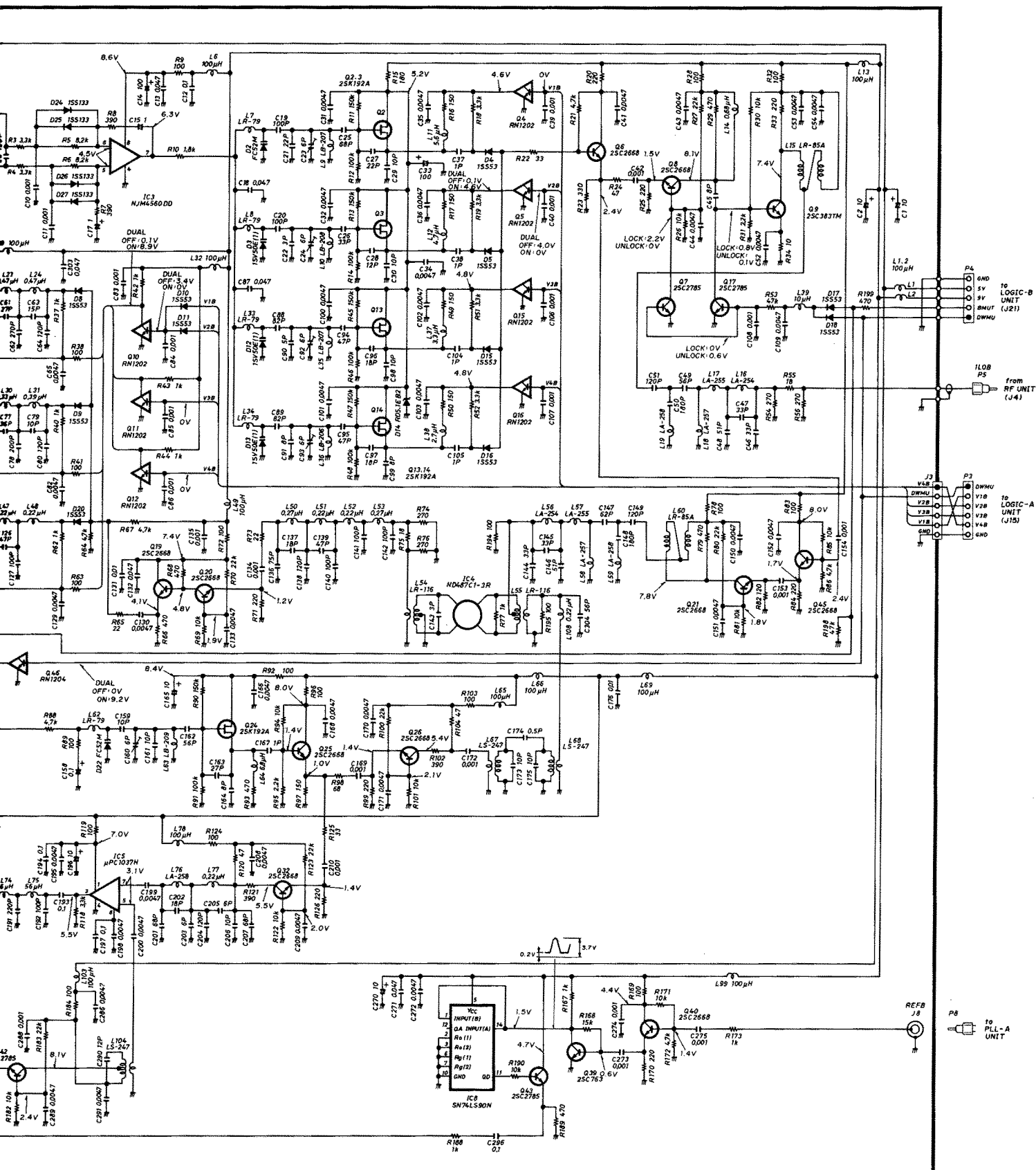





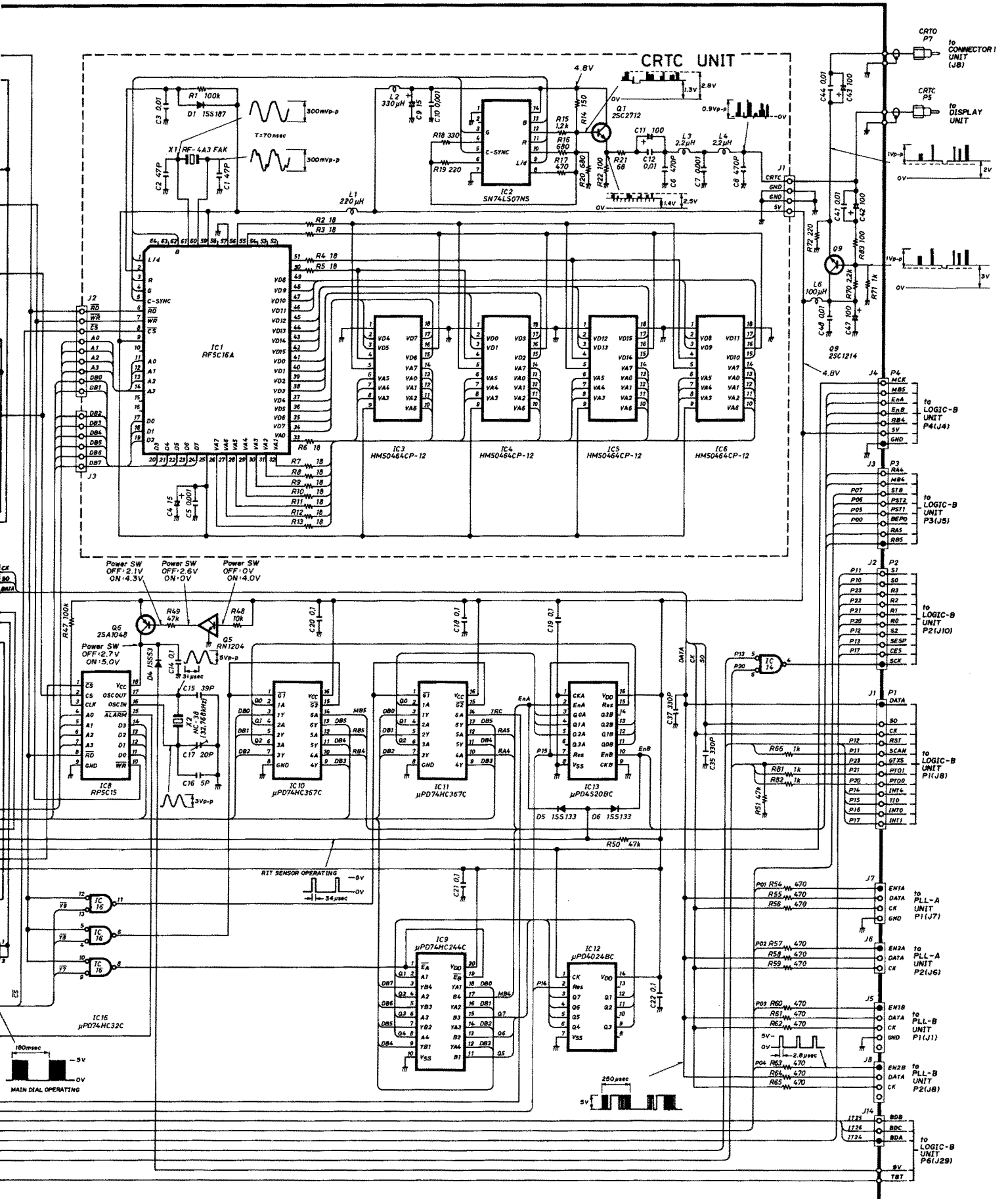

# 9-8 LOGIC-B AND SCOPE UNITS

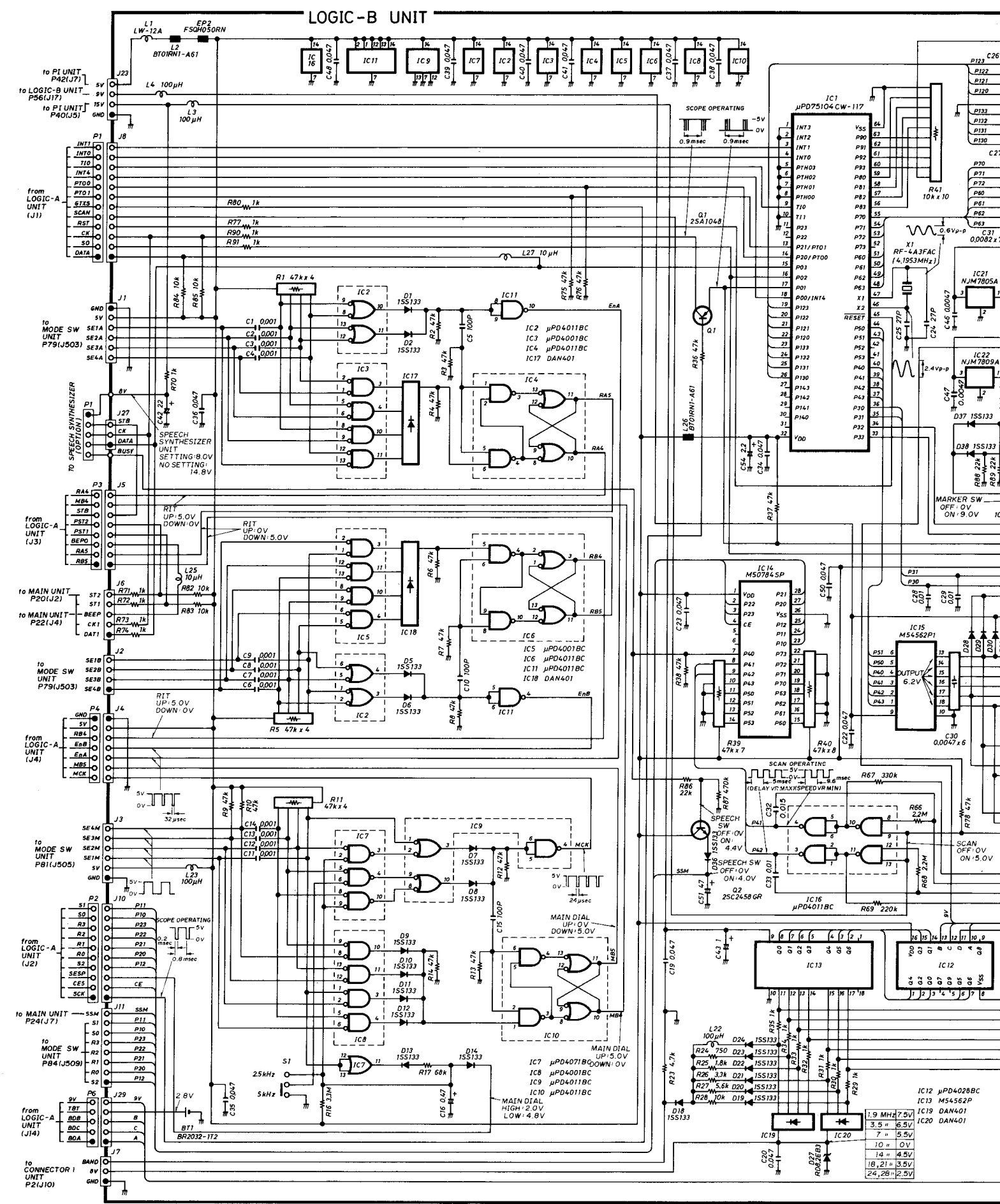





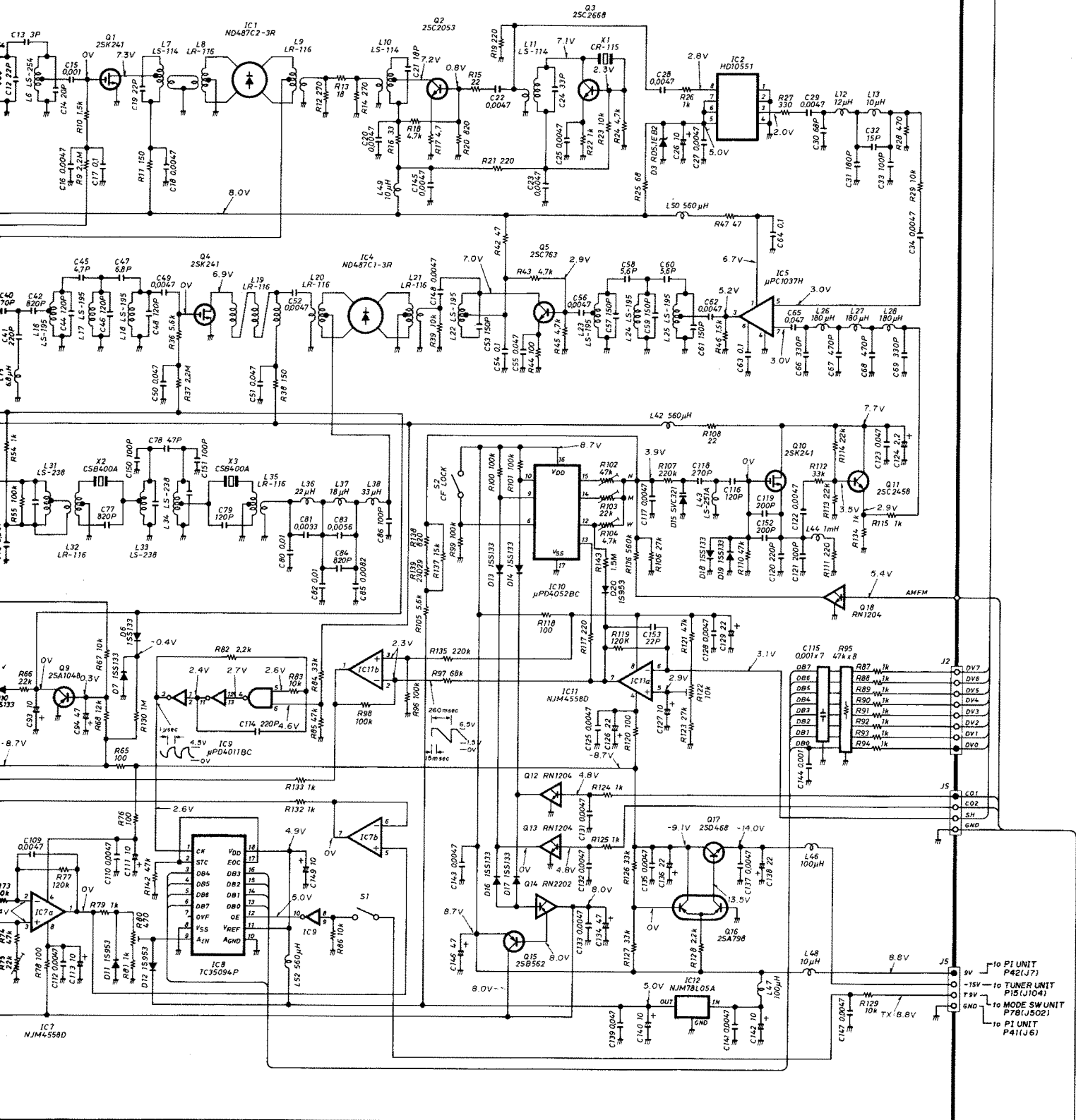

# 9-9 PI, PA, REG, FILTER AND DC-DC UNITS

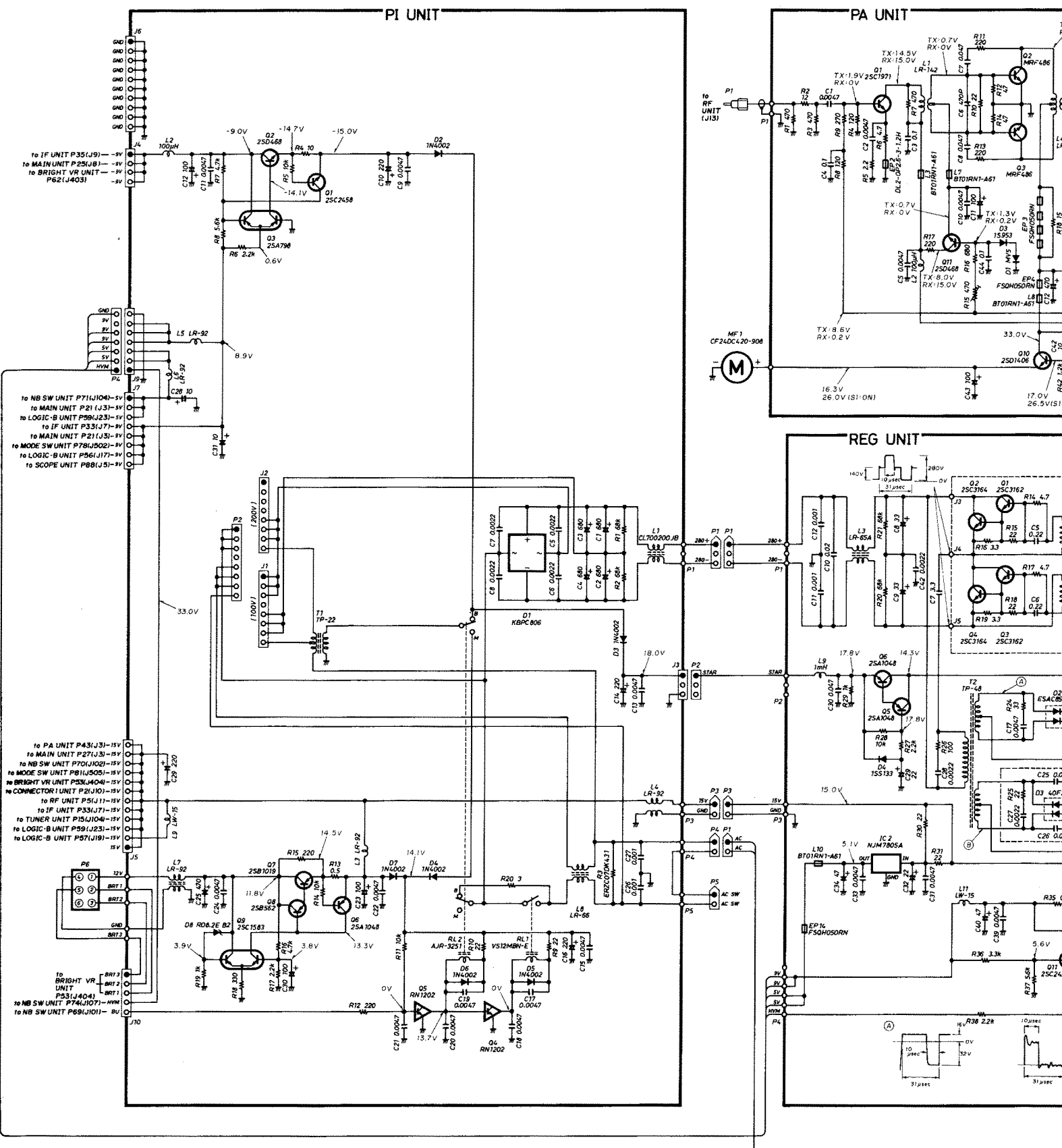

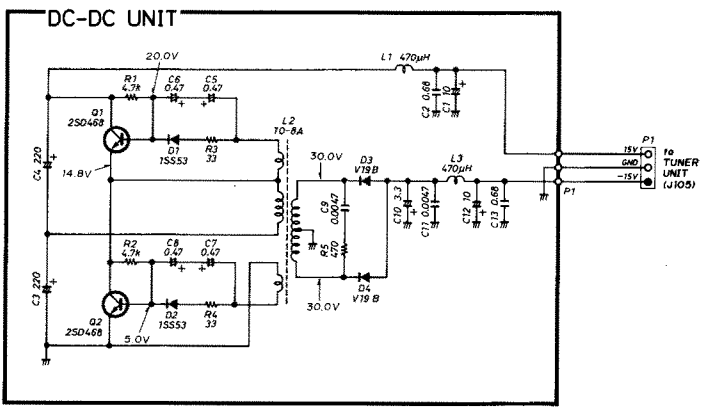
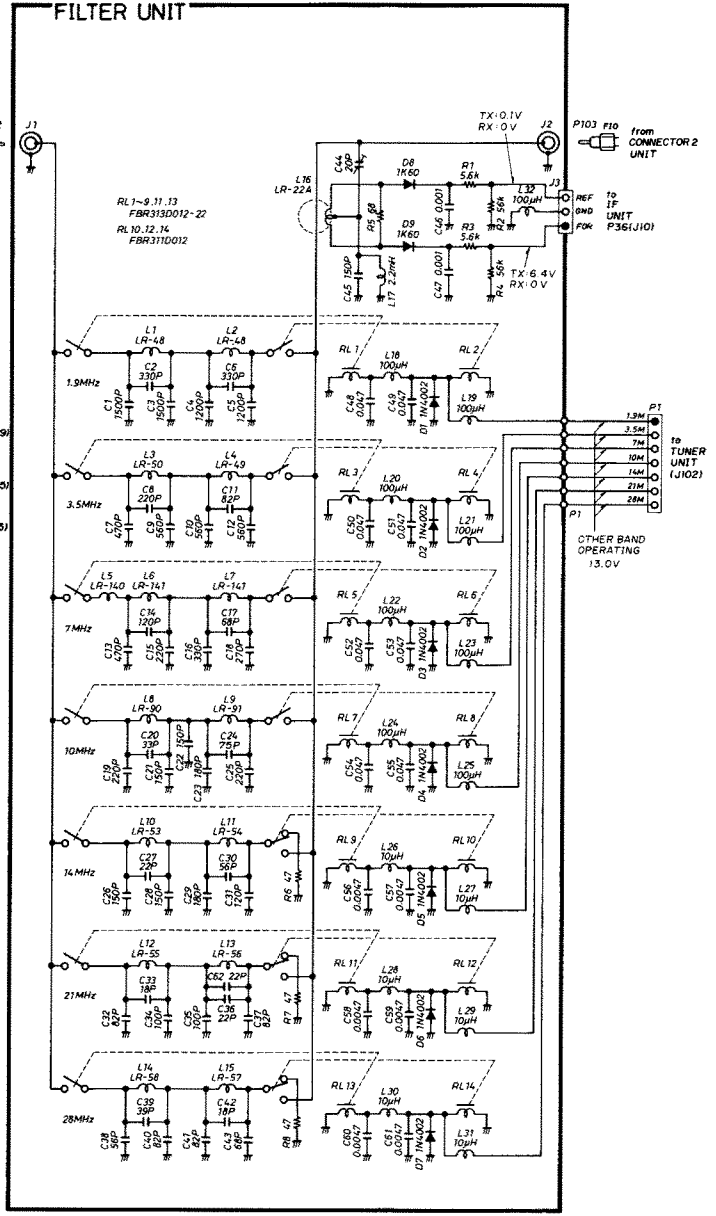
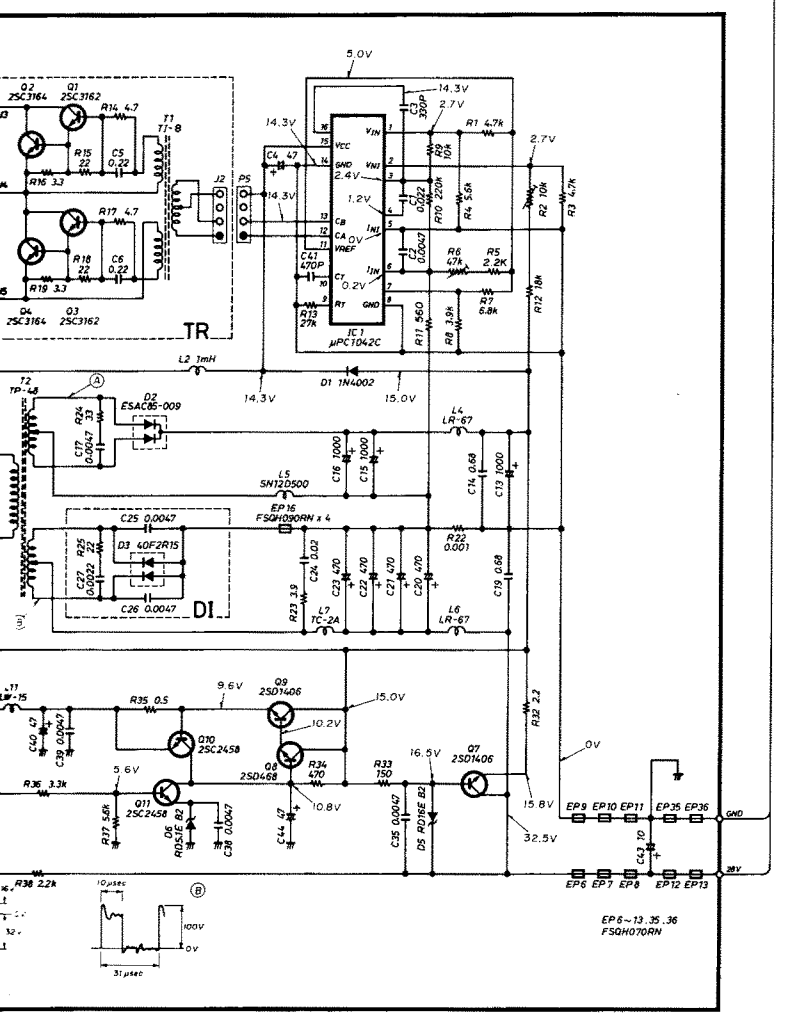
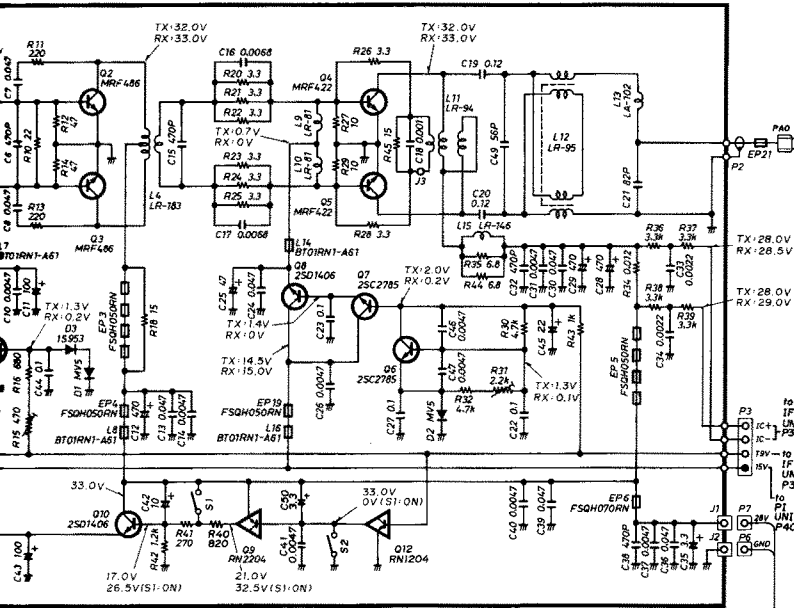





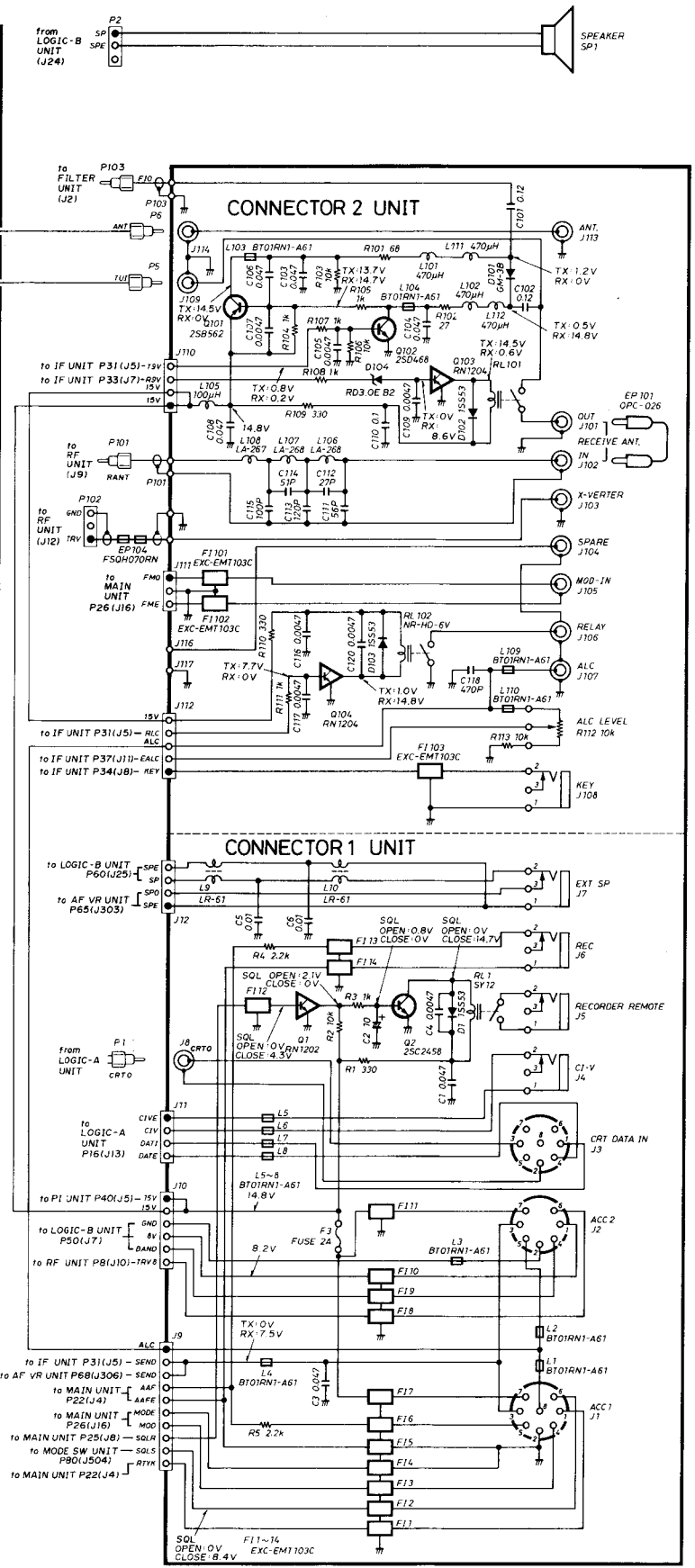
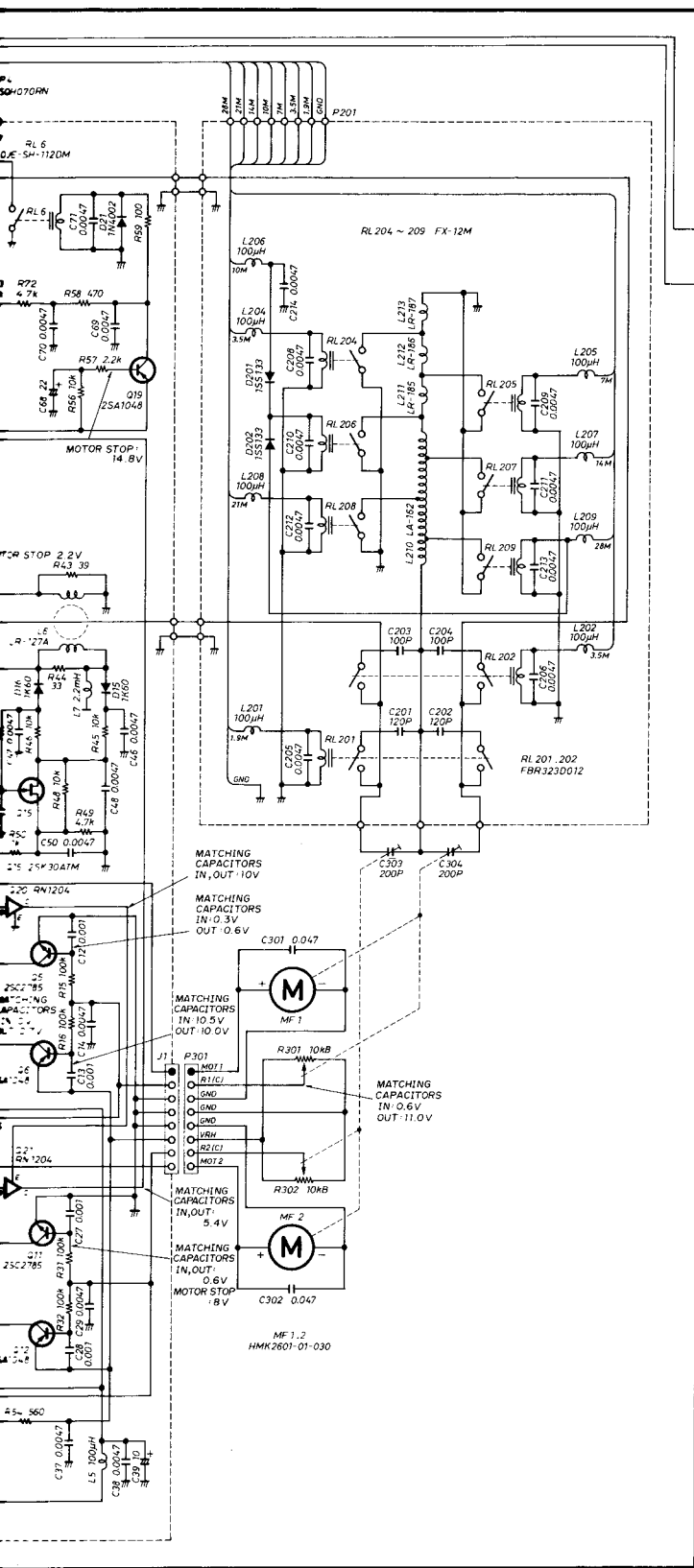

# SECTION 10 PARTS LIST

## [FRONT UNIT]

REF. NO.	DESCRIPTION	PART NO.
IC101	IC	μPD7564CS-031
IC301	IC	BA3812L
IC501	IC	M50784SP
IC502	IC	M50784SP
IC503	IC	M50784SP
IC504	IC	M50784SP
IC505	IC	TC4011BP
IC505	IC	TC4011BP
Q101	Transistor	RN1204
Q102	Transistor	RN1204
Q103	Transistor	2SD468 C
Q104	Transistor	RN1202
Q105	Transistor	2SC2458 Y
Q106	Transistor	2SD1406 Y
Q301	Transistor	2SC1571 G
Q302	Transistor	2SC2878
Q303	Transistor	2SD468 C
Q304	Transistor	2SC1645 B
Q501	Transistor	RN2202
Q502	Transistor	2SC2458 Y
Q503	Transistor	RN1202
Q504	Transistor	RN2202
Q505	Transistor	2SA1048 Y
Q506	Transistor	2SC2458 Y
Q507	Transistor	RN1204
Q508	Transistor	RN1204
Q509	Transistor	RN1204
Q510	Transistor	RN1204
Q511	Transistor	RN1204
Q512	Transistor	RN1204
Q513	Transistor	RN1202
Q514	Transistor	RN1204
Q515	Transistor	RN1204
Q516	Transistor	RN1204
Q517	Transistor	2SB562 C
Q518	Transistor	RN1204
Q519	Transistor	RN1204
Q520	Transistor	RN1204
Q522	Transistor	RN1204
Q601	Transistor	RN1404
Q602	Transistor	RN1404
Q604	Transistor	RN1404
Q605	Transistor	RN1404
D101	Diode	1SS133
D102	Diode	1SS133
D301	Diode	1SS133
D302	Diode	1S953
D303	Diode	1S953
D304	Diode	1SS53
D305	Diode	1SS53
D306	Zéner	RD6.8E B2
D501	Diode	1SS133
D502	Diode	1SS133
D503	Diode	1SS133
D504	Diode	1SS133
D505	Diode	1SS133
D506	Diode	1SS133
D507	Diode	1SS133
D508	Diode	1SS133
D509	Diode	1SS133
D510	Diode	1SS133
D511	Diode	1SS133
D512	Diode	1SS133
D513	Diode	1SS133
D514	Diode	1SS133
D515	Diode	1SS133

## [FRONT UNIT]

REF. NO.	DESCRIPTION	PART NO.
D516	Diode	1SS133
D601	Diode	1SS184
D602	Diode	1SS184
D603	Diode	1SS184
D604	Diode	1SS184
D605	Diode	1SS184
D606	Diode	1SS184
D607	Diode	1SS184
FI1	LC	EXC-EMT103C
FI2	LC	EXC-EMT103C
FI3	LC	EXC-EMT103C
FI6	LC	EXC-EMT103C
X101	Ceramic Resonator	CSB500 E
L1	Coil	BT01RN1-A61
L2	Coil	S4 101K
L3	Coil	FL5H 101K
L4	Coil	FL5H 101K
L5	Coil	FL5H 101K
L7	Coil	FL5H 101K
L8	Coil	FL5H 101K
L9	Coil	S4 101K
L10	Coil	LAL03NA 101K
L11	Coil	LAL03NA 101K
L12	Coil	LR-61
L101	Coil	LAL04NA 101K
L301	Coil	LAL03NA 101K
L501	Coil	LAL03NA 101K
L502	Coil	LAL03NA 101K
L503	Coil	LAL02NA 101K
L504	Coil	LAL02NA 101K
L506	Coil	LAL02NA 101K
L507	Coil	LAL02NA 101K
L508	Coil	LAL02NA 101K
L509	Coil	LAL02NA 101K
R1	Resistor	100 Ω R50X
R2	Resistor	100 Ω R50X
R101	Resistor	4.7 kΩ R20
R102	Resistor	4.7 kΩ R20
R103	Resistor	3.3 kΩ R20
R104	Resistor	1 kΩ R20
R105	Trimmer	100 kΩ RH0652C
R106	Resistor	22 kΩ R20
R107	Resistor	6.8 kΩ R20
R108	Resistor	1 kΩ R20
R109	Resistor	1 kΩ R20
R110	Resistor	3.9 kΩ R20
R111	Resistor	6.8 kΩ R20
R112	Resistor	100 Ω R20
R113	Resistor	100 kΩ R20
R114	Resistor	10 kΩ R20
R115	Trimmer	10 kΩ RH0652C14J0FA
R116	Trimmer	1 kΩ RH0652C13J08A
R117	Resistor	22 kΩ R20
R201	Variable Resistor	500 kΩ C RK097111004RA (KEY SPEED)
R202	Variable Resistor	1 MΩ B RK097111004PA (DELAY)
R203	Variable Resistor	10 kΩ B RK097111004NA (DRIVE)
R204	Variable Resistor	1 kΩ B RK097111004QA (NB LEVEL)



[FRONT UNIT]

REF. NO.	DESCRIPTION	PART NO.
R205	Variable Resistor	10 kΩ B RK097111004NA (BLK WIDH)
R206	Variable Resistor	1 MΩ A × 2 RK0971210012A (AGC)
R301	Resistor	3.3 kΩ R20
R302	Resistor	6.8 kΩ ELR20
R303	Resistor	6.8 kΩ R20
R304	Resistor	150 Ω R20
R305	Resistor	470 Ω R20
R306	Resistor	220 Ω ELR20
R307	Resistor	15 kΩ ELR20
R308	Resistor	56 kΩ ELR20
R309	Resistor	1 kΩ ELR20
R310	Resistor	22 kΩ ELR20
R311	Resistor	330 Ω ELR20
R312	Resistor	4.7 kΩ ELR20
R313	Resistor	4.7 kΩ ELR20
R314	Resistor	4.7 kΩ ELR20
R315	Resistor	39 kΩ ELR20
R316	Resistor	10 kΩ R20
R317	Resistor	1 kΩ ELR20
R318	Resistor	100 Ω ELR20
R319	Variable Resistor	10 kΩ B, 10 kΩ A RK124221002DA (AF/RF GAIN)
R320	Variable Resistor	100 kΩ B, 100 kΩ B RK124221002EA (BASS/TRABLE)
R321	Variable Resistor	10 kΩ B, 10 kΩ B × 2 RK124231003GA (SQL/CW)
R322	Variable Resistor	10 kΩ B × 2, 10 kΩ B RK124232000GA (RF POWER/MIC)
R323	Resistor	47 Ω ELR20
R324	Resistor	2.7 kΩ ELR20
R325	Resistor	10 kΩ ELR20
R326	Resistor	22 kΩ ELR20
R327	Resistor	1 kΩ ELR20
R328	Resistor	10 kΩ ELR20
R329	Resistor	47 kΩ ELR20
R330	Resistor	220 Ω ELR20
R401	Resistor	10 kΩ R20
R402	Resistor	2.2 kΩ R20
R403	Resistor	1 kΩ R20
R404	Trimmer	10 kΩ RH0651C14J2WA
R405	Trimmer	10 kΩ RH0651C14J2WA
R406	Resistor	1.8 kΩ R20
R407	Variable Resistor	100 kΩ B RK097111T00PA (MON GAIN)
R408	Variable Resistor	10 kΩ B RK097111T005A (VOX GAIN)
R409	Variable Resistor	10 kΩ B RK097111T005A (ANTI-VOX)
R410	Variable Resistor	1 MΩ B RK097111T003A (SCAN SPEED)
R411	Variable Resistor	1 MΩ B RK097111T003A (SCAN DELAY)
R412	Trimmer	10 kΩ B RK09K1110AAEA (CAL)
R413	Variable Resistor	100 kΩ B RK097111T00PA (MIC TONE)
R414	Variable Resistor	10 kΩ B RK097111T005A (DIMMER)
R415	Variable Resistor	100 kΩ B RK097111T00PA (BRIGHT)
R416	Resistor	68 kΩ ELR20
R501	Resistor	1.5 kΩ R20
R502	Resistor	1.5 kΩ R20
R503	Resistor	1.5 kΩ R20
R504	Resistor	1.5 kΩ R20
R505	Resistor	3.3 kΩ R20
R506	Resistor	3.3 kΩ R20
R507	Resistor	3.3 kΩ R20
R508	Resistor	3.3 kΩ R20

[FRONT UNIT]

REF. NO.	DESCRIPTION	PART NO.
R509	Resistor	1 kΩ ELR20
R510	Resistor	10 kΩ ELR20
R511	Resistor	3.3 kΩ ELR20
R512	Resistor	680 Ω ELR20
R513	Resistor	47 kΩ ELR20
R514	Resistor	1 kΩ ELR20
R515	Array	47 kΩ RMX-8
R516	Array	47 kΩ RMX-8
R517	Array	47 kΩ RMX-8
R518	Array	47 kΩ RMX-8
R519	Array	47 kΩ RMX-8
R520	Array	47 kΩ RMX-8
R521	Array	47 kΩ RMX-8
R522	Array	47 kΩ RMX-8
R523	Resistor	47 kΩ ELR20
R524	Resistor	1 kΩ R20
R525	Resistor	1 kΩ ELR20
R526	Resistor	100 kΩ ELR20
R527	Resistor	120 kΩ ELR20
R528	Resistor	270 kΩ ELR20
R529	Resistor	1 MΩ ELR20
R530	Resistor	100 kΩ ELR20
R531	Resistor	120 kΩ ELR20
R532	Resistor	270 kΩ ELR20
R533	Resistor	1 MΩ ELR20
R534	Resistor	100 kΩ ELR20
R535	Resistor	120 kΩ ELR20
R536	Resistor	270 kΩ ELR20
R537	Resistor	1 MΩ ELR20
R538	Resistor	100 kΩ ELR20
R539	Resistor	120 kΩ ELR20
R540	Resistor	270 kΩ ELR20
R541	Resistor	1 MΩ ELR20
R542	Resistor	2.7 kΩ R20
R543	Resistor	1 kΩ ELR20
R544	Resistor	2.7 kΩ ELR20
R545	Resistor	1 kΩ ELR20
R546	Resistor	2.7 kΩ R20
R547	Resistor	1 kΩ ELR20
R548	Resistor	1 kΩ R20
R549	Resistor	1 kΩ R20
R550	Resistor	1 kΩ R20
R551	Resistor	2.2 kΩ R20
R552	Resistor	2.2 kΩ R20
R553	Resistor	470 Ω ELR20
R554	Resistor	470 Ω R20
R555	Variable Resistor	10 kΩ B RK1241110024A (BALANCE)
R556	Resistor	47 kΩ ELR20
R557	Resistor	10 kΩ ELR20
R558	Resistor	10 kΩ R20
R601	Resistor	1 kΩ R20
R602	Resistor	1 kΩ R20
R603	Resistor	1 kΩ R20
R604	Resistor	1 kΩ R20
R605	Resistor	1 kΩ R20
R606	Resistor	1 kΩ R20
R607	Resistor	1 kΩ R20
R608	Resistor	1 kΩ R20
R609	Resistor	1 kΩ R20
R610	Resistor	1 kΩ R20
R611	Resistor	1 kΩ R20
R612	Resistor	1 kΩ R20
R613	Resistor	1 kΩ R20
R614	Resistor	1 kΩ R20
R615	Resistor	1 kΩ R20
R616	Resistor	1 kΩ R20
R617	Resistor	1 kΩ R20
R619	Resistor	1 kΩ R20
R801	Variable Resistor	10 kΩ B, 10 kΩ C RK1242210008A (APF/NOTCH)
R802	Resistor	2.7 kΩ R20

[FRONT UNIT]

REF. NO.	DESCRIPTION	PART NO.
C1	Ceramic	0.0047 µF 50 V
C2	Ceramic	0.0047 µF 50 V
C3	Ceramic	0.0047 µF 50 V
C4	Ceramic	0.0047 µF 50 V
C5	Ceramic	0.0047 µF 50 V
C6	Ceramic	0.0047 µF 50 V
C7	Ceramic	0.0047 µF 50 V
C101	Mylar	0.0047 µF 50 V F2D
C102	Ceramic	100 pF 50 V
C103	Ceramic	100 pF 50 V
C104	Electrolytic	2.2 µF 50 V SS
C105	Electrolytic	10 µF 16 V SS
C106	Ceramic	0.0047 µF 50 V
C107	Ceramic	0.0047 µF 50 V
C108	Ceramic	0.0047 µF 50 V
C109	Ceramic	0.0047 µF 50 V
C110	Mylar	0.047 µF 50 V F2D
C111	Ceramic	0.0047 µF 50 V
C112	Electrolytic	1 µF 50 V MS7
C113	Electrolytic	4.7 µF 25 V MS7
C301	Electrolytic	10 µF 16 V SS
C302	Electrolytic	100 µF 16 V SS
C303	Mylar	0.01 µF 50 V F2D
C304	Electrolytic	10 µF 16 V SS
C305	Electrolytic	100 µF 16 V SS
C306	Ceramic	0.0047 µF 50 V
C307	Mylar	0.022 µF 50 V F2D
C308	Barrier Layer	0.0018 µF 25 V
C309	Ceramic	0.68 µF D67X5T1H684M51
C310	Barrier Layer	0.018 µF 25 V
C311	Barrier Layer	0.047 µF 25 V
C312	Barrier Layer	0.047 µF 25 V
C313	Electrolytic	220 µF 16 V SS
C314	Barrier Layer	0.0047 µF 25 V
C315	Electrolytic	47 µF 16 V SS
C316	Ceramic	0.0047 µF 50 V
C317	Barrier Layer	0.0047 µF 25 V
C318	Electrolytic	1 µF 50 V BP
C319	Ceramic	470 pF 50 V
C320	Ceramic	0.0047 µF 50 V
C321	Electrolytic	47 µF 16 V SS
C322	Electrolytic	1 µF 50 V SS
C323	Electrolytic	47 µF 10 V SS
C324	Electrolytic	33 µF 10 V SS
C501	Ceramic	0.0047 µF 50 V
C502	Ceramic	0.0047 µF 50 V
C503	Ceramic	0.0047 µF 50 V
C504	Barrier Layer	0.1 µF 16 V
C505	Barrier Layer	0.1 µF 16 V
C506	Barrier Layer	0.1 µF 16 V
C507	Barrier Layer	0.1 µF 16 V
C508	Ceramic	0.001 µF 50 V
C509	Ceramic	0.001 µF 50 V
C510	Ceramic	0.001 µF 50 V
C511	Ceramic	0.001 µF 50 V
C512	Ceramic	0.0047 µF 50 V
C513	Ceramic	0.0047 µF 50 V
RL301	Relay	OMR-109F
J1	Connector	HLJ4815-01-030
J2	Connector	HLJ4815-01-030
J3	Connector	TL25P-03-V1
J4	Connector	TL25P-04-V1
J5	Connector	TL25P-06-V1
J6	Connector	8S-S-E
J101	Connector	TL25P-04-V1
J102	Connector	TL25P-05-V1
J103	Connector	TLB-P03H-B1
J104	Connector	TL25P-03-V1
J105	Connector	TL25P-04-V1
J106	Connector	TL25P-05-V1
J107	Connector	TL25P-07-V1

[FRONT UNIT]

REF. NO.	DESCRIPTION	PART NO.
J108	Connector	TL25P-04-V1
J109	Connector	TL25P-07-V1
J301	Connector	TL25P-06-L1
J303	Connector	TL25P-07-L1
J304	Connector	TL25P-10-L1
J305	Connector	TL25P-03-V1
J306	Connector	TL25P-09-V1
J307	Connector	TLB-P06H-B1
J401	Connector	B12B-EH-S
J402	Connector	TLB-P04H-B1
J403	Connector	B03B-EH-S
J404	Connector	B11B-EH-S
J501	Connector	TL25P-06-V1
J502	Connector	TL25P-11-V1
J503	Connector	TL25P-06-V1
J504	Connector	TL25P-08-V1
J505	Connector	TL25P-11-V1
J506	Connector	TL25P-06-V1
J508	Connector	TL25P-04-V1
J509	Connector	TL25P-07-V1
J510	Connector	TL25P-04-V1
J511	Connector	TL25P-05-V1
J512	Connector	TL25P-08-V1
J513	Connector	TL25P-05-V1
J514	Connector	TL25P-10-V1
J515	Connector	TL25P-10-V1
J516	Connector	TL25P-06-V1
J517	Connector	TL25P-08-V1
J518	Connector	TL25P-05-V1
J519	Connector	TL25P-06-V1
J521	Connector	TL25P-06-V1
J601	Connector	TLB-P10H-B1
J602	Connector	TLB-P05H-B1
J603	Connector	TLB-P10H-B1
J701	Connector	TLB-P05H-B1
J702	Connector	TLB-P06H-B1
J801	Connector	TL25P-05-V1
P101	Connector	TL25H-03-B1
P301	Connector	TL25H-06-B1
P302	Connector	TL25H-04-B1
P401	Connector	TL25H-04-B1
P402	Connector	TL25H-03-B1
P501	Connector	TL25H-08-B1
P601	Connector	TL25H-10-B1
P602	Connector	TL25H-05-B1
P603	Connector	TL25H-10-B1
P701	Connector	TL25H-05-B1
P702	Connector	TL25H-06-B1
P901	Connector	TL25H-06-B1
P1001	Connector	1545P1
DS101	LED	SLP-275D-50
DS102	LED	SLP-175D-50
DS103	Lamp	BQ044-32582A
DS501	LED	SLP-251D-50
DS502	LED	SLP-251D-50
DS503	LED	SLP-251D-50
DS504	LED	SLP-451D-50
DS505	LED	SLP-151D-50
DS506	LED	SLP-151D-50
DS901	LED	SLP-151D-50
DS902	LED	SLP-251D-50
DS903	LED	SLP-451D-50
DS904	LED	SLP-151D-50
DS905	LED	SLP-151D-50
ME1001	Meter	ME-20
S101	Switch	SPPH23079A (FULL)
S102	Switch	SPPH23079A (BK-IN)

[FRONT UNIT]

REF. NO.	DESCRIPTION	PART NO.
S103	Switch	SPPH23079A (COMP)
S104	Switch	SPPH23079A (NB SW)
S105	Switch	SPPH23079A (NB WIDTH)
S106	Switch	SPPH23079A (AGC)
S107	Switch	SPPH23079A (TUNER)
S108	Switch	SPPH23079A (TIMER)
S109	Switch	SPUV61W06A (METER SW)
S401	Switch	SPUL19233A (VOX SW)
S402	Switch	SPUL19233A (SCDLY SW)
S501	Switch	SPPQ19178A (F-1)
S502	Switch	SPPQ19178A (F-2)
S503	Switch	SPPQ19178A (F-3)
S504	Switch	SPPQ19178A (F-4)
S505	Switch	SPPQ19178A (F-5)
S506	Switch	SPPQ19178A (F-6)
S507	Switch	SPPQ19178A (LSB)
S508	Switch	SPPQ19178A (USB)
S509	Switch	SPPQ19178A (CW)
S510	Switch	SPPQ19178A (RTTY)
S511	Switch	SPPQ19178A (AM)
S512	Switch	SPPQ19178A (FM)
S513	Switch	SPPQ19178A (DATA)
S514	Switch	SPPH15061A (PRE AMP)
S515	Switch	SPPH15061A (ATT 10dB)
S516	Switch	SPPH15061A (ATT 20dB)
S517	Switch	SPPH15061A (MARKER)
S518	Switch	SPPH15061A (MONITOR)
S519	Switch	SPPH15061A (TONE)
S520	Switch	SPPH23078A (SPEECH)
S521	Switch	SPPH23079A (LOCK)
S522	Switch	SPPQ19178A (+Δf A)
S523	Switch	SPPQ19178A (CLEAR A)
S524	Switch	SPPQ19178A (ΔTX A)
S525	Switch	SPPQ19178A (RIT A)
S526	Switch	SPPQ19178A (+Δf B)
S527	Switch	SPPQ19178A (CLEAR B)
S528	Switch	SPPQ19178A (ΔTX B)
S529	Switch	SPPQ19178A (RIT B)
S530	Switch	SPPQ19178A (M-WRITE)
S531	Switch	SPPQ19178A (M-CLEAR)
S532	Switch	SPPQ19178A (M-VFO)
S533	Switch	SPPQ19178A (MEMO DW)
S534	Switch	SPPQ19178A (MEMO UP)
S535	Switch	SPPH25045A (WIDE)
S536	Switch	SPPH25045A (NARROW)
S537	Switch	SPPH25044A (9 MHz)
S538	Switch	SPPH25044A (455 kHz)
S539	Switch	SPPH25043A (APF)
S540	Switch	SPPH25043A (NOTCH)
S541	Encoder	EC24B50B0002A (A-ΔTX/RIT)
S542	Encoder	EC24B50B0002A (B-ΔTX/RIT)
S543	Switch	SSSS31124A (P/D LOCK)
S601	Switch	SKHJFC014A (KEY 1)
S602	Switch	SKHJFC014A (KEY 2)
S603	Switch	SKHJFC014A (KEY 3)
S604	Switch	SKHJFC014A (KEY 4)
S605	Switch	SKHJFC014A (KEY 5)
S606	Switch	SKHJFC014A (KEY 6)
S607	Switch	SKHJFC014A (KEY 7)
S608	Switch	SKHJFC014A (KEY 8)
S609	Switch	SKHJFC014A (KEY 9)
S610	Switch	SKHJFC014A (KEY 0)
S611	Switch	SKHJFG006A (·)
S612	Switch	SKHJFG006A (CE)
S613	Switch	SKHJFG006A (M-CH)
S614	Switch	SKHJFG006A (ENT)
S615	Switch	SKHJFG006A (SPLIT)
S616	Switch	SKHJAA025A (A=B)
S617	Switch	SKHJFH004A (A)
S618	Switch	SKHJAA025A (CHANGE)
S619	Switch	SKHJFH004A (B)
S620	Switch	SKHJAA025A (V/M)
S621	Switch	SKHJAA025A (DUAL)
S622	Switch	SKHJAA025A (XFC)
S623	Switch	SKHJFH004A (TS)

[FRONT UNIT]

REF. NO.	DESCRIPTION	PART NO.
S701	Switch	SRRS2S010A (PBT)
S1001	Switch	SDDSA3159A (POWER SW)
S1002	Switch	M2012J-1K (TX/RX SW)
EP1	P.C. Board	B-1535B (PHONES)
EP2	FPC	B-792 (MIC-PHONES)
EP3	Ferrite Bead	FSQH050RN
EP101	P.C. Board	B-1536B (NB SW)
EP201	P.C. Board	B-1537B (NB VR)
EP301	P.C. Board	B-1538B (AF VR)
EP401	P.C. Board	B-1539C (BRIGHT VR)
EP501	P.C. Board	B-1540C (MODE SW)
EP601	P.C. Board	B-1541C (TEN-KEY)
EP701	P.C. Board	B-1542 (TWIN PBT)
EP801	P.C. Board	B-1543A (NOTCH/APF)
EP901	P.C. Board	B-1544B (LED)
W1	Jumper	JPW-02A

[DISPLAY UNIT]

REF. NO.	DESCRIPTION	PART NO.
EP1	CRT	MG-550CDM

[SENSOR UNIT]

REF. NO.	DESCRIPTION	PART NO.
Q1	Photo	IS433
Q2	Photo	IS433
Q3	Transistor	RN1204
Q4	Transistor	RN1204
R1	Resistor	220 Ω ELR20
C1	Barrier Layer	0.01 μF 25 V UAT06V 103K
P1	Connector	TL25H-06-B1
DS1	LED	GL-430
DS2	LED	GL-430
EP1	P.C. Board	B-1016C



[MAIN UNIT]

REF. NO.	DESCRIPTION	PART NO.
IC1	IC	TC9181P
IC2	IC	TD6128P
IC3	IC	TD6109P
IC4	IC	μPC1037H
IC5	IC	μPC1037H
IC6	IC	TC9181P
IC7	IC	TD6128P
IC8	IC	TD6109P
IC9	IC	μPC1037H
IC10	IC	μPC1037H
IC11	IC	μPC1037H
IC12	IC	μPC1037H
IC13	IC	TC9181P
IC14	IC	TD6128P
IC15	IC	M54459L
IC16	IC	M74LS90P
IC17	IC	TC9181P
IC18	IC	M74LS90P
IC19	IC	M74LS90P
IC20	IC	S7116A
IC21	IC	μPD4001BC
IC22	IC	μPC1241H
IC23	IC	NJM4558D
IC24	IC	NJM4558D
IC25	IC	NJM4558D
IC26	IC	μPD4066BC
IC27	IC	μPD4066BC
IC28	IC	μPC1037H
IC29	IC	μPC1037H
IC30	IC	NJM4558D
IC31	IC	M5218L
IC32	IC	NJM4558D
Q1	Transistor	2SC2785 EF
Q2	FET	2SK192A GR
Q3	Transistor	2SC2668 O
Q4	Transistor	2SC2785 EF
Q5	Transistor	2SC2785 EF
Q6	FET	2SK241 Y
Q7	FET	2SK192A GR
Q8	Transistor	2SC2668 O
Q9	Transistor	2SC2785 EF
Q10	Transistor	2SC2785 EF
Q11	FET	2SK241 Y
Q12	Transistor	RN1204
Q13	Transistor	RN1204
Q14	FET	2SK241 Y
Q15	Transistor	2SC2785 EF
Q16	Transistor	2SC2785 EF
Q17	Transistor	RN1204
Q18	Transistor	2SC2785 EF
Q19	FET	2SK192A GR
Q20	Transistor	2SC2668 O
Q22	Transistor	2SC2785 EF
Q23	Transistor	2SC2785 EF
Q24	Transistor	2SC2785 EF
Q25	Transistor	RN2204
Q26	Transistor	2SC2668 O
Q27	Transistor	2SC2668 O
Q28	Transistor	RN1202
Q29	Transistor	2SC2785 EF
Q30	FET	2SJ105 GR
Q31	Transistor	2SC2785 EF
Q32	Transistor	RN1204
Q33	Transistor	RN1204
Q34	Transistor	2SC2785 EF
Q35	FET	2SJ105 GR
Q36	Transistor	2SC2458 GR
Q37	Transistor	2SC2458 GR
Q38	FET	2SJ105 GR
Q39	Transistor	RN1204
Q40	FET	2SJ105 GR
Q41	Transistor	RN1204
Q42	Transistor	RN1204

[MAIN UNIT]

REF. NO.	DESCRIPTION	PART NO.
Q43	Transistor	2SC2785 EF
Q44	FET	3SK74 M
Q45	FET	3SK74 M
Q46	Transistor	2SC2785 EF
Q47	Transistor	RN1204
Q48	Transistor	RN1204
Q49	Transistor	RN2204
Q50	Transistor	RN2202
Q51	Transistor	RN2202
Q52	Transistor	RN1204
Q53	Transistor	2SA1048 GR
Q54	Transistor	2SA1048 GR
Q55	Transistor	2SA1048 GR
Q56	Transistor	2SC2785 EF
Q57	Transistor	RN1204
Q58	Transistor	RN1204
Q59	Transistor	RN1204
Q60	FET	2SJ105 GR
Q61	Transistor	2SC2878
Q62	Transistor	RN2202
Q63	Transistor	2SC2785 EF
Q64	FET	2SJ105 GR
D1	Varicap	1SV50E
D2	Diode	1SS237
D3	Varicap	1SV50E
D4	Diode	1SS237
D5	Varicap	1SV50E
D6	Diode	M1204
D7	Diode	1SS265
D9	Diode	1SS216
D10	Diode	1SS216
D11	Diode	1SS216
D12	Zener	RD5.1E B2
D13	Varicap	1SV50E
D14	Diode	1SS237
D15	Varicap	1SV50E
D16	Varicap	1SV50E
D17	Diode	1SS216
D18	Diode	1SS216
D19	Diode	1SS53
D20	Zener	MZ304 B
D21	Diode	1SS99
D22	Diode	1SS133
D23	Diode	1SS133
D24	Diode	1SS133
D25	Diode	1SS133
D26	Diode	1SS133
D27	Diode	1SS133
D28	Diode	1SS133
D29	Diode	1SS133
D30	Diode	1SS133
D31	Diode	1SS133
D32	Diode	1SS133
D33	Diode	1S953
D34	Diode	1K60
D35	Diode	1K60
D38	Diode	1SS133
D39	Diode	1SS133
D40	Diode	1SS133
D41	Diode	1SS133
D42	Diode	1SS133
D43	Diode	1SS133
D44	Diode	1SS133
D45	Diode	1SS216
D46	Diode	1SS216
D47	Diode	1SS99
D48	Diode	1S953
D49	Diode	1SS99
D50	Diode	1SS133
D51	Diode	1SS133
D52	Diode	1SS237
D53	Diode	1SS133
D54	Diode	1SS237

[MAIN UNIT]

REF. NO.	DESCRIPTION	PART NO.
D55	Diode	1SS133
D56	Diode	1SS133
D57	Diode	1SS133
D58	Diode	1SS133
D59	Diode	1SS133
D60	Diode	1SS133
D61	Diode	1SS133
D62	Diode	1SS53
D63	Diode	1SS53
D64	Diode	1SS133
D65	Diode	1SS99
D66	Diode	1SS99
D68	Diode	1SS133
D69	Diode	1SS133
D71	Diode	MV5W
D72	Zener	RD5.1E B2
F11	Monolithic	FL-93
F12	Monolithic	FL-92
F13	Monolithic	FL-97
F14	Monolithic	FL-37
X1	Crystal	CR-233
X2	Crystal	CR-232
X3	Crystal	CR-232
X4	Crystal	CR-234
X5	Crystal	CR-231
L1	Coil	LS-157
L2	Coil	LS-128
L3	Coil	LAL03NA 2R2M
L4	Coil	LAL03NA 101K
L5	Coil	LAL03NA 101K
L6	Coil	LAL03NA 100K
L7	Coil	LAL03NA 120K
L8	Coil	LAL03NA 100K
L9	Coil	LAL03NA 4R7K
L10	Coil	LAL03NA 5R6K
L11	Coil	LS-157
L12	Coil	LR-86
L13	Coil	LR-86
L14	Coil	LS-128
L15	Coil	LAL03NA 3R3K
L16	Coil	LAL03NA 101K
L17	Coil	LAL03NA 101K
L18	Coil	LS-292
L19	Coil	LAL03NA 150K
L20	Coil	LAL03NA 180K
L21	Coil	LAL03NA 150K
L22	Coil	LS-223
L23	Coil	LS-223
L24	Coil	LAL03NA 4R7K
L25	Coil	LS-157
L27	Coil	LS-117
L28	Coil	LAL03NA 101K
L29	Coil	LAL03NA 560K
L30	Coil	LAL03NA 560K
L31	Coil	LS-163
L33	Coil	LR-86
L34	Coil	LR-86
L35	Coil	LS-163
L36	Coil	LS-292
L37	Coil	LS-128
L38	Coil	LAL03NA 3R3K
L39	Coil	LAL03NA 101K
L40	Coil	LAL03NA 101K
L41	Coil	LS-96
L42	Coil	LAL03NA 101K
L43	Coil	LAL03NA 101K
L44	Coil	LS-292
L45	Coil	LAL03NA 101K
L46	Coil	LAL03NA 101K

[MAIN UNIT]

REF. NO.	DESCRIPTION	PART NO.
L47	Coil	LAL03NA 390K
L48	Coil	LAL03NA 180K
L49	Coil	LAL03NA 180K
L50	Coil	LAL03NA 101K
L51	Coil	LAL03NA 101K
L52	Coil	LAL03NA 561K
L53	Coil	LAL04NA 101K
L54	Coil	BT01RN1-A61
L57	Coil	FL9H 471K
L59	Coil	LW-15
L60	Coil	LS-151
L61	Coil	LS-151
L62	Coil	LAL03NA 390K
L64	Coil	LS-303
L66	Coil	LAL03NA 101K
L68	Coil	LAL03NA 101K
L69	Coil	LAL03NA 101K
L70	Coil	LAL03NA 101K
L71	Coil	LAL03NA 101K
L72	Coil	LAL03NA 101K
L73	Coil	LAL03NA 101K
R1	Resistor	2.2 kΩ R20
R2	Resistor	22 kΩ ELR20
R3	Resistor	22 kΩ ELR20
R4	Resistor	330 Ω R25
R5	Resistor	330 Ω ELR20
R6	Resistor	47 Ω ELR20
R7	Array	100 kΩ RMX-8
R8	Resistor	150 kΩ ELR20
R9	Resistor	1 kΩ ELR20
R10	Resistor	33 kΩ ELR20
R11	Resistor	100 Ω R25
R12	Resistor	150 Ω R20
R13	Resistor	47 Ω ELR20
R14	Resistor	150 Ω ELR20
R15	Resistor	10 kΩ ELR20
R16	Resistor	10 kΩ ELR20
R17	Resistor	330 Ω ELR20
R18	Resistor	1 kΩ R25
R19	Resistor	1 kΩ R25
R20	Resistor	1 kΩ R25
R21	Resistor	82 Ω ELR20
R22	Resistor	10 kΩ R20
R23	Resistor	470 Ω ELR20
R24	Resistor	220 Ω ELR20
R25	Resistor	100 Ω ELR20
R26	Resistor	220 Ω R20
R27	Resistor	1.5 kΩ R20
R28	Resistor	6.8 kΩ ELR20
R29	Resistor	6.8 kΩ R20
R30	Resistor	330 Ω ELR20
R31	Resistor	220 Ω ELR20
R32	Resistor	220 Ω ELR20
R33	Resistor	2.2 kΩ ELR20
R34	Resistor	100 Ω ELR20
R35	Resistor	82 Ω ELR20
R36	Resistor	2.2 kΩ ELR20
R37	Resistor	330 Ω R20
R38	Resistor	56 Ω R20
R39	Resistor	100 kΩ ELR20
R40	Resistor	1 kΩ ELR20
R41	Resistor	33 kΩ ELR20
R42	Resistor	100 Ω R25
R43	Resistor	47 Ω ELR20
R44	Resistor	150 Ω ELR20
R45	Resistor	10 kΩ ELR20
R46	Resistor	10 kΩ ELR20
R47	Resistor	330 Ω ELR20
R48	Resistor	1 kΩ R25
R49	Resistor	1 kΩ R20
R50	Resistor	1 kΩ R25
R51	Resistor	150 Ω R25
R52	Resistor	82 kΩ ELR20

[MAIN UNIT]

REF. NO.	DESCRIPTION	PART NO.	
R53	Resistor	10 kΩ	R20
R54	Resistor	470 Ω	ELR20
R55	Resistor	220 Ω	ELR20
R56	Resistor	10 kΩ	ELR20
R57	Resistor	10 kΩ	ELR20
R58	Resistor	47 Ω	R20
R59	Resistor	47 Ω	R20
R60	Resistor	22 kΩ	ELR20
R61	Resistor	22 kΩ	ELR20
R62	Resistor	22 kΩ	ELR20
R63	Resistor	220 Ω	R20
R64	Resistor	330 Ω	R20
R65	Resistor	1 kΩ	R25
R66	Resistor	220 Ω	ELR20
R67	Resistor	2.2 kΩ	ELR20
R68	Resistor	100 Ω	ELR20
R69	Resistor	220 Ω	R20
R70	Resistor	2.2 kΩ	ELR20
R71	Resistor	2.2 kΩ	ELR20
R72	Resistor	330 Ω	R20
R73	Resistor	56 Ω	R20
R74	Resistor	220 Ω	R25
R75	Resistor	2.2 kΩ	ELR20
R76	Resistor	2.2 kΩ	ELR20
R77	Resistor	330 Ω	R20
R78	Resistor	150 Ω	R20
R79	Resistor	2.2 kΩ	R20
R80	Resistor	100 Ω	ELR20
R81	Resistor	22 kΩ	ELR20
R82	Resistor	22 kΩ	ELR20
R83	Resistor	470 Ω	ELR20
R84	Resistor	220 Ω	R25
R85	Resistor	220 Ω	ELR20
R86	Resistor	10 kΩ	ELR20
R87	Resistor	3.3 kΩ	ELR20
R88	Resistor	4.7 kΩ	R20
R89	Resistor	4.7 kΩ	ELR20
R90	Resistor	4.7 kΩ	R20
R91	Resistor	4.7 kΩ	R20
R92	Resistor	47 kΩ	R20
R93	Resistor	47 kΩ	R20
R94	Resistor	10 kΩ	R20
R95	Resistor	22 kΩ	ELR20
R96	Resistor	22 kΩ	ELR20
R97	Resistor	330 Ω	ELR20
R98	Resistor	3.3 kΩ	R20
R99	Resistor	390 Ω	R20
R100	Resistor	33 kΩ	ELR20
R101	Resistor	1 kΩ	ELR20
R102	Resistor	100 kΩ	ELR20
R103	Resistor	1.5 kΩ	R25
R104	Resistor	150 Ω	R20
R105	Resistor	47 kΩ	ELR20
R106	Resistor	150 Ω	ELR20
R107	Resistor	10 Ω	ELR20
R108	Resistor	10 kΩ	R20
R109	Resistor	330 Ω	R20
R110	Resistor	1 kΩ	R25
R111	Resistor	1 kΩ	R25
R112	Resistor	1 kΩ	R25
R113	Resistor	4.7 kΩ	ELR20
R114	Resistor	2.2 kΩ	R20
R115	Resistor	15 kΩ	R25
R116	Resistor	10 kΩ	R20
R117	Resistor	10 kΩ	R20
R118	Resistor	10 kΩ	ELR20
R119	Resistor	470 Ω	R20
R120	Resistor	1 kΩ	R20
R121	Resistor	10 kΩ	ELR20
R122	Resistor	22 kΩ	ELR20
R123	Resistor	150 Ω	ELR20
R124	Resistor	150 Ω	R25
R125	Resistor	22 kΩ	ELR20
R126	Resistor	10 kΩ	R20
R127	Resistor	1 kΩ	ELR20

[MAIN UNIT]

REF. NO.	DESCRIPTION	PART NO.	
R128	Resistor	1 kΩ	ELR20
R129	Resistor	1 kΩ	ELR20
R130	Resistor	1 kΩ	R20
R131	Resistor	220 Ω	R20
R132	Resistor	10 kΩ	R20
R133	Resistor	10 kΩ	R20
R134	Resistor	10 kΩ	R20
R135	Resistor	22 kΩ	ELR20
R136	Resistor	22 kΩ	R20
R137	Resistor	220 Ω	ELR20
R138	Resistor	100 Ω	R20
R139	Resistor	100 Ω	R20
R140	Resistor	10 kΩ	R25
R141	Resistor	15 kΩ	ELR20
R142	Resistor	1 kΩ	ELR20
R143	Resistor	15 kΩ	ELR20
R144	Resistor	1 kΩ	ELR20
R145	Resistor	2.2 kΩ	ELR20
R146	Resistor	2.2 kΩ	ELR20
R147	Resistor	1.5 kΩ	ELR20
R148	Resistor	1 kΩ	ELR20
R149	Resistor	680 Ω	ELR20
R150	Resistor	2.2 kΩ	R20
R151	Resistor	10 kΩ	ELR20
R152	Resistor	22 kΩ	ELR20
R153	Resistor	56 Ω	ELR20
R154	Resistor	56 Ω	ELR20
R155	Resistor	100 Ω	ELR20
R156	Resistor	1 kΩ	ELR20
R157	Resistor	10 kΩ	R20
R158	Resistor	22 kΩ	ELR20
R159	Resistor	220 Ω	R25
R160	Resistor	6.8 kΩ	ELR20
R161	Resistor	22 kΩ	ELR20
R162	Resistor	4.7 kΩ	R20
R163	Resistor	1 kΩ	R20
R164	Resistor	10 kΩ	ELR20
R165	Resistor	220 Ω	R20
R166	Resistor	47 kΩ	ELR20
R167	Resistor	100 kΩ	ELR20
R168	Resistor	100 kΩ	ELR20
R169	Resistor	470 Ω	R25
R170	Resistor	47 kΩ	R20
R171	Resistor	47 kΩ	ELR20
R172	Resistor	4.7 kΩ	ELR20
R173	Resistor	4.7 kΩ	ELR20
R174	Resistor	47 kΩ	ELR20
R175	Resistor	22 kΩ	ELR20
R176	Resistor	10 kΩ	ELR20
R177	Resistor	1 kΩ	R25
R178	Resistor	47 kΩ	ELR20
R179	Trimmer	1 kΩ	RH0651C13J1YA
R180	Resistor	1 Ω	ELR25
R181	Resistor	1 kΩ	R20
R182	Resistor	3.3 Ω	ELR20
R183	Resistor	100 Ω	R20
R184	Resistor	68 kΩ	ELR20
R185	Resistor	220 Ω	R20
R186	Trimmer	4.7 kΩ	RH0651CS3J2KA
R187	Resistor	680 kΩ	ELR20
R188	Resistor	10 kΩ	R20
R189	Resistor	2.7 kΩ	R20
R190	Resistor	2.7 kΩ	R20
R193	Resistor	10 kΩ	ELR20
R194	Trimmer	10 kΩ	RH0651C14J2WA
R195	Resistor	220 kΩ	ELR20
R197	Resistor	4.7 kΩ	ELR20
R198	Resistor	2.2 kΩ	ELR20
R199	Trimmer	4.7 kΩ	RH0651CS3J2KA
R200	Resistor	2.2 MΩ	ELR20
R201	Resistor	12 kΩ	R20
R202	Resistor	100 kΩ	R20
R203	Resistor	10 kΩ	R20
R204	Resistor	100 kΩ	R20
R205	Resistor	220 Ω	R20



[MAIN UNIT]

REF. NO.	DESCRIPTION	PART NO.
R206	Resistor	220 kΩ R25
R207	Resistor	220 Ω R20
R208	Resistor	560 kΩ ELR20
R209	Resistor	10 kΩ R20
R210	Resistor	10 kΩ R20
R211	Resistor	3.3 kΩ R20
R212	Resistor	68 kΩ ELR20
R213	Resistor	47 kΩ ELR20
R214	Resistor	10 kΩ ELR20
R215	Resistor	47 kΩ R25
R216	Resistor	100 Ω R25
R217	Resistor	2.2 kΩ R20
R218	Resistor	47 kΩ ELR20
R219	Resistor	22 kΩ ELR20
R220	Resistor	10 kΩ R20
R221	Resistor	8.2 kΩ R20
R222	Resistor	8.2 kΩ ELR20
R223	Resistor	2.2 kΩ R20
R224	Resistor	2.2 kΩ R25
R225	Resistor	47 kΩ ELR20
R226	Resistor	100 Ω R20
R227	Resistor	10 kΩ R20
R228	Resistor	10 kΩ R20
R229	Resistor	10 kΩ R20
R230	Resistor	100 Ω R20
R231	Resistor	100 Ω R20
R232	Resistor	2.2 kΩ R20
R233	Resistor	5.6 kΩ ELR20
R234	Resistor	22 kΩ R20
R235	Resistor	100 kΩ ELR20
R236	Resistor	47 kΩ R20
R237	Resistor	4.7 kΩ ELR25
R238	Resistor	4.7 kΩ ELR20
R239	Resistor	47 kΩ ELR20
R240	Resistor	47 kΩ ELR20
R245	Resistor	22 kΩ ELR20
R246	Resistor	4.7 kΩ R20
R247	Resistor	47 kΩ ELR20
R248	Resistor	47 kΩ ELR20
R249	Resistor	47 kΩ ELR20
R250	Resistor	47 kΩ R25
R251	Resistor	47 kΩ ELR20
R252	Resistor	4.7 kΩ R20
R253	Resistor	4.7 kΩ ELR25
R254	Resistor	220 Ω ELR20
R255	Resistor	100 Ω R20
R256	Resistor	10 kΩ R20
R257	Resistor	22 kΩ ELR20
R258	Resistor	220 Ω R20
R259	Resistor	1 kΩ ELR20
R260	Resistor	22 kΩ ELR25
R261	Resistor	100 Ω ELR20
R262	Resistor	56 Ω ELR20
R263	Resistor	100 Ω ELR20
R264	Trimmer	470 Ω RH0651CS2J1HA
R265	Trimmer	10 kΩ RH0651C14J2WA
R266	Resistor	100 Ω R20
R267	Trimmer	470 Ω RH0651CS2J1HA
R268	Resistor	100 Ω ELR20
R269	Resistor	56 Ω ELR20
R270	Resistor	2.2 kΩ ELR20
R271	Resistor	2.2 kΩ ELR20
R272	Resistor	2.2 kΩ ELR20
R273	Resistor	2.2 kΩ ELR20
R274	Resistor	4.7 kΩ R20
R275	Resistor	5.6 kΩ ELR20
R276	Trimmer	10 kΩ RH0421C14J08A
R277	Resistor	1 kΩ ELR20
R278	Resistor	220 Ω R20
R279	Resistor	1.5 kΩ ELR20
R280	Resistor	220 Ω R20
R281	Resistor	1 kΩ R20
R282	Resistor	100 Ω R20
R283	Resistor	47 kΩ ELR20
R284	Resistor	100 kΩ ELR20

[MAIN UNIT]

REF. NO.	DESCRIPTION	PART NO.
R285	Resistor	330 kΩ ELR20
R286	Resistor	680 Ω R20
R287	Resistor	47 kΩ ELR20
R288	Resistor	100 Ω ELR25
R289	Resistor	47 kΩ ELR20
R290	Resistor	390 kΩ ELR25
R291	Resistor	10 kΩ ELR20
R292	Resistor	10 kΩ R20
R293	Resistor	47 kΩ R25
R294	Resistor	1 kΩ ELR20
R295	Resistor	100 kΩ ELR20
R296	Resistor	100 Ω R25
R297	Resistor	10 kΩ R20
R298	Resistor	2.2 kΩ ELR20
R299	Resistor	5.6 kΩ ELR20
R300	Resistor	39 kΩ R20
R301	Resistor	5.6 kΩ ELR25
R302	Resistor	1 MΩ ELR20
R303	Resistor	4.7 kΩ ELR20
R304	Trimmer	33 kΩ RH0651CN4J0TA
R305	Resistor	100 Ω ELR25
R306	Resistor	1.2 MΩ R20
R307	Resistor	470 Ω ELR20
R308	Trimmer	2.2 kΩ RH0651CJ3J0CA
R309	Resistor	100 kΩ R25
R310	Resistor	100 kΩ ELR20
R311	Trimmer	220 kΩ RH0651CJ5J01A
R312	Resistor	100 kΩ R20
R313	Resistor	270 kΩ ELR20
R314	Resistor	1 MΩ ELR20
R315	Resistor	2.2 MΩ ELR20
R316	Resistor	10 kΩ R20
R317	Resistor	10 kΩ ELR20
R318	Resistor	10 kΩ R20
R319	Resistor	47 Ω R20
R320	Resistor	68 kΩ R20
R321	Resistor	1 kΩ R25
R323	Resistor	4.7 kΩ R20
R324	Thermistor	33D28
R325	Trimmer	4.7 kΩ RH0651CS3J2KA
R326	Array	47 kΩ RMX-6
R327	Resistor	100 kΩ R20
R328	Resistor	100 kΩ R20
R329	Resistor	4.7 kΩ R20
R330	Resistor	47 kΩ R20
R331	Resistor	4.7 kΩ R20
R332	Resistor	47 kΩ R20
R335	Resistor	47 kΩ ELR20
R336	Resistor	15 kΩ R20
R337	Thermistor	33D28
R338	Resistor	2.2 kΩ ELR20
R339	Resistor	47 kΩ ELR20
R340	Resistor	12 kΩ ELR20
R341	Resistor	22 kΩ R20
R342	Resistor	10 kΩ ELR20
R343	Resistor	22 kΩ ELR20
R346	Resistor	10 kΩ R20
R347	Resistor	2.7 kΩ ELR20
R348	Resistor	47 kΩ ELR20
R349	Resistor	470 Ω ELR20
R350	Resistor	47 kΩ R20
R351	Resistor	470 Ω R20
R354	Resistor	4.7 kΩ ELR20
R355	Resistor	2.2 kΩ ELR20
R356	Resistor	1 kΩ ELR20
R357	Thermistor	23D29
R358	Resistor	2.2 kΩ R20
C1	Ceramic	75 pF 50 V
C2	Ceramic	0.001 μF 50 V
C3	Ceramic	0.0047 μF 50 V
C4	Mylar	0.0047 μF 50 V F2D
C5	Ceramic	0.001 μF 50 V
C6	Ceramic	100 pF 50 V

[MAIN UNIT]

REF. NO.	DESCRIPTION	PART NO.
C7	Ceramic	12 pF 50 V UJ
C8	Ceramic	3 pF 50 V CH
C9	Ceramic	22 pF 50 V CH
C10	Ceramic	0.0047 μF 50 V
C11	Ceramic	4 pF 50 V CH
C12	Ceramic	4 pF 50 V CH
C13	Ceramic	1 pF 50 V
C14	Electrolytic	100 μF 10 V SS
C15	Ceramic	330 pF 50 V
C16	Ceramic	100 pF 50 V
C17	Ceramic	0.0047 μF 50 V
C18	Electrolytic	10 μF 16 V MS7
C19	Ceramic	0.0047 μF 50 V
C20	Ceramic	0.0047 μF 50 V
C21	Barrier Layer	0.047 μF 25 V
C22	Ceramic	0.0047 μF 50 V
C23	Ceramic	0.001 μF 50 V
C24	Barrier Layer	820 pF 50 V RAU08SA 821K
C25	Barrier Layer	0.0015 μF 25 V
C26	Barrier Layer	0.0015 μF 25 V
C27	Barrier Layer	820 pF 50 V RAU08SA 821K
C28	Barrier Layer	0.01 μF 25 V
C29	Ceramic	33 pF 50 V
C30	Ceramic	0.0047 μF 50 V
C31	Barrier Layer	0.047 μF 25 V
C32	Ceramic	47p μF 50 V
C33	Barrier Layer	0.1 μF 16 V
C34	Ceramic	0.001 μF 50 V
C35	Ceramic	0.0047 μF 50 V
C36	Ceramic	330 pF 50 V
C37	Ceramic	0.0047 μF 50 V
C38	Ceramic	0.0047 μF 50 V
C39	Ceramic	51 pF 50 V
C40	Ceramic	0.0047 μF 50 V
C41	Ceramic	150 pF 50 V
C42	Ceramic	0.001 μF 50 V
C43	Mylar	0.0047 μF 50 V F2D
C44	Ceramic	100 pF 50 V
C45	Ceramic	22 pF 50 V CH
C46	Ceramic	15 pF 50 V TH
C47	Ceramic	0.0047 μF 50 V
C48	Ceramic	4 pF 50 V CH
C49	Ceramic	4 pF 50 V CH
C50	Ceramic	1 pF 50 V
C51	Electrolytic	100 μF 10 V SS
C52	Ceramic	330 pF 50 V
C53	Ceramic	100 pF 50 V
C54	Ceramic	0.0047 μF 50 V
C55	Electrolytic	10 μF 16 V MS7
C56	Ceramic	0.0047 μF 50 V
C57	Barrier Layer	0.047 μF 25 V
C58	Ceramic	0.0047 μF 50 V
C59	Ceramic	0.0047 μF 50 V
C60	Ceramic	0.0047 μF 50 V
C61	Ceramic	100 pF 50 V CH
C62	Ceramic	100 pF 50 V CH
C63	Ceramic	0.0047 μF 50 V
C64	Cylinder	0.0047 μF UP125X 472M-NA
C65	Ceramic	0.0047 μF 50 V
C66	Ceramic	0.0047 μF 50 V
C67	Barrier Layer	0.1 μF 16 V
C68	Ceramic	0.001 μF 50 V
C69	Barrier Layer	0.001 μF 25 V
C70	Barrier Layer	0.0022 μF 25 V
C71	Barrier Layer	0.0022 μF 25 V
C72	Barrier Layer	0.001 μF 25 V
C73	Ceramic	0.0047 μF 50 V
C74	Ceramic	47 pF 50 V
C75	Ceramic	0.0047 μF 50 V
C76	Ceramic	0.0047 μF 50 V
C77	Ceramic	47 pF 50 V
C78	Ceramic	0.0047 μF 50 V
C79	Ceramic	100 pF 50 V
C80	Ceramic	330 pF 50 V
C81	Ceramic	22 pF 50 V

[MAIN UNIT]

REF. NO.	DESCRIPTION	PART NO.
C82	Ceramic	330 pF 50 V
C83	Cylinder	0.0047 μF UP125X 472M-NA
C84	Cylinder	47 pF UP125SL 470J-NA
C85	Ceramic	0.0047 μF 50 V
C86	Barrier Layer	0.047 μF 25 V
C88	Ceramic	0.0047 μF 50 V
C90	Barrier Layer	0.0012 μF 25 V
C91	Barrier Layer	0.0039 μF 25 V
C92	Barrier Layer	0.0056 μF 25 V
C93	Barrier Layer	0.0033 μF 25 V
C94	Ceramic	0.0047 μF 50 V
C95	Barrier Layer	0.1 μF 16 V
C96	Barrier Layer	0.1 μF 16 V
C97	Ceramic	0.0047 μF 50 V
C98	Ceramic	10 pF 50 V
C99	Ceramic	0.0047 μF 50 V
C100	Ceramic	0.0047 μF 50 V
C101	Ceramic	0.0047 μF 50 V
C102	Ceramic	0.5 pF 50 V
C104	Ceramic	22 pF 50 V CH
C105	Ceramic	30 pF 50 V CH
C106	Trimmer	50 pF CV05E5001
C107	Trimmer	50 pF CV05E5001
C108	Ceramic	0.0047 μF 50 V
C109	Ceramic	100 pF 50 V CH
C110	Ceramic	100 pF 50 V CH
C111	Ceramic	0.0047 μF 50 V
C112	Ceramic	0.001 μF 50 V
C113	Mylar	0.01 μF 50 V F2D
C114	Cylinder	10 pF UP125SL 100J-NA
C115	Ceramic	33 pF 50 V SH
C116	Ceramic	15 pF 50 V TH
C117	Ceramic	33 pF 50 V CH
C118	Ceramic	0.0047 μF 50 V
C119	Ceramic	5 pF 50 V CH
C120	Ceramic	5 pF 50 V CH
C121	Ceramic	1.5 pF 50 V
C122	Electrolytic	100 μF 10 V SS
C123	Ceramic	330 pF 50 V
C124	Ceramic	330 pF 50 V
C125	Ceramic	0.0047 pF 50 V
C126	Electrolytic	10 μF 16 V MS7
C127	Ceramic	0.0047 μF 50 V
C128	Barrier Layer	0.047 μF 25 V
C129	Electrolytic	100 μF 10 V SS
C130	Barrier Layer	0.1 μF 16 V
C131	Ceramic	0.0047 μF 50 V
C132	Tantalum	4.7 μF 16 V DN
C133	Tantalum	0.1 μF 35 V DN
C134	Ceramic	0.0047 μF 50 V
C135	Ceramic	100 pF 50 V CH
C136	Ceramic	100 pF 50 V UJ
C137	Ceramic	22 pF 50 V CH
C138	Ceramic	0.0047 μF 50 V
C139	Ceramic	100 pF 50 V UJ
C140	Ceramic	100 pF 50 V UJ
C141	Ceramic	47 pF 50 V
C142	Electrolytic	100 μF 10 V SS
C143	Ceramic	1 pF 50 V
C144	Ceramic	100 pF 50 V
C145	Ceramic	0.0047 μF 50 V
C146	Electrolytic	10 μF 16 V MS7
C147	Ceramic	0.0047 μF 50 V
C148	Ceramic	100 pF 50 V UJ
C149	Ceramic	100 pF 50 V UJ
C150	Ceramic	0.0047 μF 50 V
C151	Ceramic	100 pF 50 V
C152	Ceramic	0.0047 μF 50 V
C153	Ceramic	100 pF 50 V
C154	Barrier Layer	0.1 μF 16 V
C155	Ceramic	470 pF 50 V SL
C156	Barrier Layer	0.0027 μF 25 V
C157	Barrier Layer	0.0022 μF 25 V
C158	Barrier Layer	0.0012 μF 25 V
C159	Ceramic	220 pF 50 V

[MAIN UNIT]

REF. NO.	DESCRIPTION	PART NO.
C160	Ceramic	390 pF 50 V
C161	Ceramic	220 pF 50 V
C162	Ceramic	0.001 μF 50 V
C163	Barrier Layer	0.047 μF 25 V
C164	Electrolytic	0.47 μF 50 V SS
C165	Ceramic	0.001 μF 50 V
C166	Ceramic	0.0047 μF 50 V
C167	Ceramic	0.0047 μF 50 V
C168	Electrolytic	2.2 μF 50 V MS7
C169	Barrier Layer	0.047 μF 25 V
C170	Electrolytic	0.47 μF 50 V MS7
C171	Ceramic	10 pF 50 V
C172	Ceramic	10 pF 50 V
C173	Barrier Layer	0.1 μF 16 V
C174	Electrolytic	100 μF 10 V SS
C175	Ceramic	0.0047 μF 50 V
C176	Ceramic	0.0047 μF 50 V
C177	Electrolytic	0.47 μF 50 V SS
C178	Barrier Layer	0.1 μF 16 V
C180	Barrier Layer	0.1 μF 16 V
C181	Barrier Layer	0.1 μF 16 V
C182	Electrolytic	470 μF 16 V SS
C183	Electrolytic	47 μF 16 V SS
C184	Electrolytic	100 μF 16 V SS
C185	Electrolytic	47 μF 16 V SS
C186	Ceramic	0.0047 μF 50 V
C187	Ceramic	0.0047 μF 50 V
C188	Electrolytic	1000 μF 16 V MS16
C190	Mylar	0.0047 μF 50 V F2D
C191	Electrolytic	10 μF 16 V MS7
C192	Mylar	0.0047 μF 50 V F2D
C193	Mylar	0.0047 μF 50 V F2D
C194	Mylar	0.0047 μF 50 V F2D
C195	Electrolytic	10 μF 16 V MS7
C196	Electrolytic	10 μF 16 V MS7
C198	Electrolytic	10 μF 16 V MS7
C199	Electrolytic	100 μF 10 V SS
C200	Ceramic	0.0047 μF 50 V
C201	Electrolytic	10 μF 16 V MS7
C202	Mylar	0.0047 μF 50 V F2D
C203	Electrolytic	1 μF 50 V MS7
C204	Electrolytic	4.7 μF 25 V MS7
C205	Electrolytic	100 μF 10 V SS
C206	Mylar	0.01 μF 50 V F2D
C207	Electrolytic	100 μF 10 V SS
C208	Electrolytic	1 μF 50 V MS7
C209	Electrolytic	1 μF 50 V MS7
C210	Ceramic	330 pF 50 V
C211	Electrolytic	10 μF 16 V MS7
C212	Electrolytic	10 μF 16 V MS7
C213	Ceramic	330 pF 50 V
C214	Mylar	0.01 μF 50 V F2D
C215	Mylar	0.0047 μF 50 V F2D
C216	Electrolytic	0.47 μF 50 V MS7
C217	Electrolytic	10 μF 16 V MS7
C218	Electrolytic	22 μF 10 V SS
C219	Electrolytic	0.1 μF 50 V MS7
C220	Ceramic	470 pF 50 V
C221	Electrolytic	1 μF 50 V MS7
C222	Electrolytic	0.1 μF 50 V MS7
C223	Tantalum	0.1 μF 35 V DN
C224	Electrolytic	220 μF 10 V SS
C225	Ceramic	0.0047 μF 50 V
C226	Electrolytic	0.47 μF 50 V SS
C227	Electrolytic	0.47 μF 50 V SS
C228	Ceramic	0.0047 μF 50 V
C229	Ceramic	0.001 μF 50 V
C230	Ceramic	33 pF 50 V
C231	Ceramic	0.0047 pF 50 V
C232	Ceramic	100 pF 50 V
C233	Ceramic	0.0047 μF 50 V
C234	Ceramic	0.0047 μF 50 V
C236	Ceramic	0.0047 μF 50 V
C237	Ceramic	0.0047 μF 50 V
C238	Ceramic	0.001 μF 50 V

[MAIN UNIT]

REF. NO.	DESCRIPTION	PART NO.
C239	Ceramic	0.0047 μF 50 V
C240	Ceramic	0.0047 μF 50 V
C241	Ceramic	0.0047 μF 50 V
C242	Ceramic	39 pF 50 V CH
C243	Trimmer	10 pF CV38D1001
C244	Ceramic	39 pF 50 V CH
C245	Ceramic	0.0047 μF 50 V
C246	Ceramic	390 pF 50 V
C247	Barrier Layer	0.1 μF 16 V
C248	Barrier Layer	0.1 μF 16 V
C249	Cylinder	0.0047 μF UP125X 472M-NA
C250	Barrier Layer	0.1 μF 16 V
C251	Electrolytic	10 μF 16 V MS7
C252	Electrolytic	0.47 μF 50 V MS7
C253	Barrier Layer	0.0082 μF 25 V
C254	Barrier Layer	0.0082 μF 25 V
C255	Electrolytic	0.47 μF 50 V MS7
C256	Electrolytic	10 μF 16 V MS7
C257	Mylar	0.022 μF 50 V F2D
C258	Ceramic	330 pF 50 V
C259	Ceramic	0.0047 μF 50 V
C260	Ceramic	0.0047 μF 50 V
C261	Barrier Layer	0.1 μF 16 V
C262	Electrolytic	33 μF 16 V SS
C263	Electrolytic	4.7 μF 50 V MS7
C264	Electrolytic	0.33 μF 50 V MS7
C265	Barrier Layer	0.047 μF 25 V
C266	Ceramic	0.0047 μF 50 V
C267	Electrolytic	10 μF 16 V MS7
C268	Electrolytic	4.7 μF 25 V MS7
C269	Electrolytic	4.7 μF 25 V MS7
C270	Ceramic	0.0047 μF 50 V
C271	Array	0.0047 μF × 6 B7ZC0714-32N
C272	Ceramic	22 pF 50 V CH
C273	Ceramic	0.0047 μF 50 V
C274	Ceramic	0.001 μF 50 V
C275	Ceramic	0.0047 μF 50 V
C276	Electrolytic	0.22 μF 50 V MS7
C277	Mylar	0.0047 μF 50 V F2D
C278	Electrolytic	47 μF 16 V SS
C279	Electrolytic	47 μF 16 V SS
C281	Ceramic	100 pF 50 V
C282	Ceramic	0.0047 μF 50 V
C283	Ceramic	0.0047 μF 50 V
C284	Ceramic	2 pF 50 V CK
C285	Mylar	0.047 μF 50 V F2D
C286	Ceramic	0.0047 μF 50 V
C287	Electrolytic	10 μF 16 V MS7
C288	Ceramic	0.001 μF 50 V
C289	Barrier Layer	0.047 μF 25 V
J1	Connector	TMP-J01X-A2
J2	Connector	TL25P-12-V1
J3	Connector	TL25P-05-V1
J4	Connector	TL25P-11-V1
J5	Connector	TL25P-06-V1
J6	Connector	TL25P-07-V1
J7	Connector	TL25P-10-V1
J8	Connector	TL25P-11-V1
J9	Connector	TL25P-10-V1
J10	Connector	TMP-J01X-A2
J11	Connector	TMP-J01X-A2
J12	Connector	TMP-J01X-A2
J13	Connector	TMP-J01X-A2
J14	Connector	TMP-J01X-A2
J15	Connector	TSL-P03P-B1
J16	Connector	TL25P-07-V1
J17	Connector	IMSA-9201B-2-04T
J18	Connector	TLB-P05H-B1
J19	Connector	TLB-P03H-B1
P1	Connector	IMSA-9201B-HT



**[MAIN UNIT]**

REF. NO.	DESCRIPTION	PART NO.
S1	Switch	SSSS31124A (RTTY MARK)
S2	Switch	SSSS31124A (HIGH/LOW TONE)
EP1	P.C. Board	B-1327C
W83	Jumper	JPW-02A
W84	Jumper	JPW-02A

**[IDC UNIT]**

REF. NO.	DESCRIPTION	PART NO.
IC1	IC	NJM4558M
R2	Resistor	5.6 kΩ MCR10
R4	Resistor	82 kΩ MCR10
R5	Resistor	82 kΩ MCR10
R6	Resistor	82 kΩ MCR10
R7	Resistor	10 kΩ MCR10
R8	Resistor	2.7 kΩ MCR10
R9	Resistor	1 kΩ MCR10
C1	Tantalum	1 μF 16 V SV
C2	Ceramic	0.001 μF GRM40 SL
C3	Ceramic	0.0022 μF GR42-6 SL
C4	Ceramic	120 pF GRM40
J1	Connector	50002-8107
EP1	P.C. Board	B-1328C

**[IF UNIT]**

REF. NO.	DESCRIPTION	PART NO.
IC1	IC	TC4011BP
IC2	IC	TC4011BP
IC3	IC	M5218L
IC4	IC	M5218L
IC5	IC	M5218L
IC6	IC	M5218L
IC7	IC	M54562P
IC8	IC	μPC1037H
IC9	IC	μPC1037H
IC10	IC	MC3357P
IC11	IC	μPC1037H
IC12	IC	μPC1037H
IC13	IC	μPC1037H
IC14	IC	ND487C1-3R
Q1	Transistor	RN1204
Q2	Transistor	RN1204
Q3	Transistor	2SD468 C
Q4	Transistor	2SC2458 GR

**[IF UNIT]**

REF. NO.	DESCRIPTION	PART NO.
Q5	Transistor	RN1204
Q6	Transistor	2SC2785 FF
Q7	Transistor	RN1204
Q8	Transistor	RN1202
Q9	Transistor	2SC2785 FF
Q10	Transistor	2SD880 Y
Q11	Transistor	2SC2785 FF
Q12	Transistor	2SD880 Y
Q13	Transistor	RN1204
Q14	Transistor	RN1204
Q15	Transistor	2SC2785 FF
Q16	Transistor	RN1204
Q17	Transistor	RN1204
Q18	Transistor	RN1204
Q19	Transistor	RN1204
Q20	Transistor	RN2202
Q21	Transistor	RN1204
Q22	Transistor	2SC2458 GR
Q23	Transistor	2SC2458 GR
Q24	Transistor	2SC2458 GR
Q25	Transistor	RN1204
Q26	Transistor	RN1204
Q27	Transistor	RN1204
Q28	Transistor	RN1204
Q29	Transistor	RN1204
Q30	Transistor	2SC2458 GR
Q31	Transistor	2SC2458 GR
Q32	FET	3SK74 M
Q33	Transistor	2SA1048 GR
Q34	Transistor	2SA1048 GR
Q35	Transistor	RN1204
Q36	Transistor	2SA1048 GR
Q37	Transistor	2SA1048 GR
Q38	FET	2SK241 Y
Q39	FET	3SK74 M
Q40	Transistor	2SC2458 GR
Q41	Transistor	RN1204
Q42	Transistor	RN2204
Q43	FET	2SK241 Y
Q44	Transistor	2SC2785 FF
Q45	Transistor	RN1204
Q46	FET	2SK241 Y
Q47	Transistor	2SC2785 FF
Q48	Transistor	2SA1048 GR
Q49	Transistor	2SC2458 GR
Q50	Transistor	2SC2785 FF
Q51	FET	3SK74 M
Q52	Transistor	RN1202
Q53	Transistor	2SC2785 FF
Q54	Transistor	RN1204
Q55	Transistor	2SC2458 GR
Q56	FET	3SK74 M
Q57	FET	3SK74 M
Q58	FET	2SK125
Q59	FET	3SK74 M
Q60	FET	3SK74 M
Q61	FET	3SK74 M
Q62	Transistor	2SC2458 GR
Q63	Transistor	2SC2458 GR
Q64	Transistor	2SA1048 GR
Q65	Transistor	2SC2458 GR
Q66	Transistor	2SA1048 GR
Q67	Transistor	2SA1048 GR
Q68	Transistor	2SC2458 GR
Q69	Transistor	2SC2458 GR
Q70	Transistor	RN1202
Q71	Transistor	2SC2668 O
Q72	Transistor	2SC2458 GR
Q73	Transistor	RN1202
Q74	Transistor	2SC2785 FF
D1	Zener	RD6.8E B3
D2	Diode	1SS133
D3	Diode	1SS133

[IF UNIT]

REF. NO.	DESCRIPTION	PART NO.
D4	Diode	1SS133
D5	Diode	1SS133
D6	Diode	1SS133
D7	Diode	1SS133
D8	Diode	1SS133
D9	Diode	1SS133
D11	Diode	1SS133
D12	Diode	1SS133
D13	Diode	1SS133
D14	Diode	1SS133
D15	Diode	1SS133
D16	Diode	1SS133
D17	Diode	1SS133
D18	Diode	1SS133
D19	Diode	1SS133
D20	Diode	1SS133
D21	Diode	1SS133
D22	Diode	1SS133
D23	Diode	1SS133
D24	Diode	1SS133
D25	Diode	1SS133
D26	Diode	1SS133
D27	Diode	1SS133
D28	Diode	1SS133
D29	Diode	1SS133
D30	Diode	1SS133
D31	Diode	1SS133
D32	Diode	1SS133
D33	Diode	1SS133
D36	Diode	1SS53
D37	Diode	1SS53
D38	Zener	RD3.6E B1
D39	Diode	1SS53
D40	Diode	1SS53
D41	Diode	1SS237
D42	Diode	1SS237
D43	Diode	1SS53
D44	Diode	1SS265
D45	Zener	RD6.8E B3
D46	Diode	1SS133
D47	Diode	1SS133
D48	Diode	1SS133
D49	Diode	1SS216
D50	Diode	1SS216
D51	Diode	1SS216
D52	Diode	1SS216
D53	Diode	1SS216
D54	Diode	1SS216
D55	Diode	1SS216
D56	Diode	1SS216
D57	Diode	1SS265
D58	Diode	1SS216
D59	Diode	1SS53
D60	Diode	1SS53
D61	Diode	1SS53
D62	Diode	1SS133
D63	Diode	1K60
D64	Diode	1SS133
D65	Diode	1SS211
D66	Diode	1SS211
D67	Diode	1SS53
D69	Diode	1SS53
D70	Diode	1SS53
D71	Diode	1SS53
D72	Diode	1SS53
D73	Diode	1SS53
D74	Diode	1SS53
D75	Diode	1SS53
D76	Diode	1SS53
D77	Diode	1SS53
D78	Diode	1SS53
D79	Diode	1SS53
D80	Diode	1SS53
D81	Diode	1SS53
D82	Diode	1SS53

[IF UNIT]

REF. NO.	DESCRIPTION	PART NO.
D83	Diode	1SS53
D84	Diode	1SS53
D85	Diode	1SS53
D86	Diode	1SS53
D87	Diode	1SS53
D88	Diode	1SS53
D89	Diode	1SS53
D90	Diode	1SS53
D91	Diode	1SS216
D92	Diode	1SS53
D93	Diode	1SS53
D94	Diode	1SS53
D95	Diode	1SS53
D96	Diode	1SS53
D97	Diode	1SS53
D98	Diode	1K60
D99	Diode	1K60
D100	Diode	1SS133
D101	Diode	1SS133
D102	Diode	1SS133
D103	Diode	1SS133
D104	Diode	1SS133
D105	Diode	1SS133
D106	Diode	1SS133
D107	Diode	1SS133
D108	Diode	1SS133
F11	Ceramic	CFW455 E
F12	Crystal	FL-96
F13	Crystal	FL-52A
F14	Ceramic	CFW455 IT
F15	Monolithic	FL-80
F16	Crystal	FL-32A
F17	Monolithic	FL-94
F18	Crystal	FL-53A
F19	Crystal	FL-101
F110	Monolithic	FL-102
L1	Coil	BT01RN1-A61
L2	Coil	LAL04NA 101K
L3	Coil	LAL04NA 101K
L4	Coil	LAL03NA 101K
L5	Coil	LAL03NA 101K
L6	Coil	LAL03NA 101K
L7	Coil	LS-100
L8	Coil	LS-251A
L9	Coil	LS-251A
L10	Coil	LAL03NA 100K
L11	Coil	LS-163
L12	Coil	LR-86
L13	Coil	LS-175
L14	Coil	LS-121
L15	Coil	LAL03NA 101K
L16	Coil	LS-240
L17	Coil	LS-251A
L18	Coil	LS-251A
L19	Coil	LAL03NA 102K
L20	Coil	LS-146
L21	Coil	LS-146
L22	Coil	LAL03NA 2R7M
L23	Coil	LS-175
L24	Coil	LS-175
L25	Coil	LS-90A
L26	Coil	LS-90A
L27	Coil	LS-175
L28	Coil	LS-163
L29	Coil	LAL03NA 1R2M
L30	Coil	LAL03NA R82M
L31	Coil	LS-175
L32	Coil	LAL03NA 101K
L33	Coil	LS-175
L34	Coil	LS-175

[IF UNIT]

REF. NO.	DESCRIPTION	PART NO.
L35	Coil	LS-175
L36	Coil	LR-116
L37	Coil	LR-116
L38	Coil	LR-86
L39	Coil	LS-198
L40	Coil	LS-249
L41	Coil	LR-116
L44	Coil	BT01RN1-A61
L45	Coil	BT01RN1-A61
L46	Coil	BT01RN1-A61
L47	Coil	LAL03NA 101K
L48	Coil	LAL03NA 101K
L49	Coil	LAL03NA 101K
L50	Coil	LAL03NA 101K
L51	Coil	LS-175
L52	Coil	LAL03NA 102K
L53	Coil	LAL03NA 102K
L54	Coil	LAL03NA 102K
L55	Coil	LAL03NA 1R0M
R1	Resistor	120 Ω R25
R2	Resistor	10 kΩ R25
R3	Resistor	47 kΩ ELR20
R4	Resistor	4.7 kΩ ELR20
R5	Resistor	2.2 kΩ ELR25
R6	Resistor	15 kΩ ELR20
R7	Resistor	47 kΩ ELR20
R8	Resistor	4.7 kΩ ELR20
R9	Resistor	4.7 kΩ ELR20
R10	Resistor	10 kΩ R20
R11	Resistor	56 kΩ ELR20
R12	Resistor	56 kΩ ELR20
R13	Resistor	39 kΩ R20
R14	Resistor	4.7 kΩ R20
R15	Resistor	1 kΩ ELR20
R16	Resistor	10 Ω ELR25
R17	Resistor	4.7 kΩ R25
R18	Resistor	1 kΩ R20
R19	Resistor	10 Ω R25
R20	Resistor	4.7 kΩ R20
R21	Resistor	22 kΩ R20
R22	Resistor	47 kΩ R25
R23	Resistor	100 kΩ R20
R24	Resistor	10 kΩ ELR20
R25	Resistor	10 kΩ ELR20
R26	Trimmer	47 kΩ RH0651CS4J25A
R27	Trimmer	33 kΩ RH0651CN4J0TA
R28	Trimmer	470 Ω RH0421CS2J05A
R29	Resistor	27 kΩ CRB25FX
R30	Resistor	18 kΩ CRB25FX
R31	Resistor	18 kΩ CRB25FX
R32	Resistor	27 kΩ CRB25FX
R33	Resistor	100 Ω R25
R34	Resistor	1 MΩ CRB25FX
R35	Resistor	1 MΩ CRB25FX
R36	Trimmer	10 kΩ RH0651C14J2WA
R37	Trimmer	10 kΩ RH0651C14J2WA
R38	Resistor	1 kΩ ELR20
R39	Resistor	680 Ω R25
R40	Resistor	1.8 MΩ ELR20
R41	Resistor	220 kΩ R25
R42	Resistor	680 kΩ R25
R43	Trimmer	10 kΩ RH0651C14J2WA
R44	Resistor	100 kΩ ELR20
R45	Resistor	100 kΩ R20
R46	Resistor	100 kΩ ELR20
R47	Resistor	100 kΩ R20
R48	Resistor	15 kΩ ELR20
R49	Trimmer	47 kΩ RH0421CS4J08A
R50	Resistor	150 kΩ ELR20
R51	Resistor	1 MΩ ELR20
R52	Resistor	220 kΩ ELR20
R53	Resistor	56 kΩ R20
R54	Resistor	33 kΩ R20

[IF UNIT]

REF. NO.	DESCRIPTION	PART NO.
R55	Resistor	150 kΩ ELR20
R56	Resistor	220 kΩ ELR20
R57	Trimmer	10 kΩ RH0651C14J2WA
R58	Resistor	47 kΩ R20
R59	Resistor	27 kΩ ELR20
R60	Resistor	6.8 kΩ ELR20
R61	Resistor	4.7 kΩ ELR20
R62	Resistor	100 kΩ ELR20
R63	Resistor	1 MΩ R20
R64	Resistor	680 kΩ R20
R65	Resistor	2.2 MΩ ELR20
R66	Trimmer	47 kΩ RH0651CS4J25A
R67	Resistor	2.2 kΩ R20
R68	Resistor	4.7 kΩ ELR20
R69	Resistor	220 kΩ ELR20
R70	Resistor	100 Ω R20
R71	Resistor	10 kΩ R25
R72	Resistor	6.8 kΩ ELR20
R73	Trimmer	10 kΩ RH0651C14J2WA
R74	Resistor	100 Ω R20
R75	Trimmer	10 kΩ RH0651C14J2WA
R76	Trimmer	2.2 kΩ RH0651CJ3J0CA
R78	Resistor	100 Ω R20
R79	Resistor	5.6 kΩ R20
R80	Resistor	5.6 kΩ R20
R81	Resistor	2.2 kΩ R20
R82	Resistor	470 Ω ELR20
R83	Resistor	1 kΩ ELR20
R84	Resistor	1 kΩ R20
R85	Resistor	4.7 kΩ R20
R86	Resistor	1 kΩ ELR20
R87	Resistor	4.7 kΩ ELR20
R89	Resistor	10 kΩ R20
R90	Resistor	10 kΩ ELR20
R91	Resistor	10 kΩ R20
R92	Resistor	68 kΩ ELR20
R93	Resistor	4.7 kΩ R20
R94	Resistor	4.7 kΩ ELR20
R95	Resistor	10 kΩ R20
R96	Resistor	33 kΩ R20
R97	Resistor	100 Ω R20
R98	Resistor	47 kΩ R20
R99	Resistor	56 Ω R20
R100	Resistor	56 Ω ELR20
R101	Resistor	330 Ω ELR20
R102	Resistor	220 Ω R20
R103	Resistor	3.3 kΩ R20
R104	Resistor	33 kΩ ELR20
R106	Trimmer	47 kΩ RH0651CS4J25A
R107	Resistor	1 MΩ ELR20
R108	Resistor	100 Ω ELR20
R109	Resistor	4.7 kΩ ELR20
R110	Resistor	2.2 kΩ R20
R111	Resistor	4.7 kΩ ELR20
R112	Resistor	4.7 kΩ ELR20
R113	Resistor	2.2 kΩ ELR20
R114	Resistor	100 Ω R20
R115	Resistor	220 Ω R20
R116	Resistor	3.3 kΩ ELR20
R117	Resistor	22 kΩ R20
R118	Resistor	56 Ω R20
R119	Resistor	68 kΩ ELR20
R120	Resistor	4.7 kΩ R20
R121	Resistor	330 Ω ELR20
R122	Trimmer	22 kΩ RH0651CJ4J01A
R123	Resistor	220 Ω R20
R124	Resistor	3.3 kΩ R20
R125	Resistor	10 kΩ R20
R126	Resistor	220 Ω R25
R127	Resistor	10 kΩ ELR20
R128	Resistor	33 kΩ ELR20
R129	Resistor	220 Ω R25
R130	Resistor	68 kΩ ELR20
R131	Resistor	10 kΩ R20
R132	Trimmer	10 kΩ RH0651C14J2WA



[IF UNIT]

REF. NO.	DESCRIPTION	PART NO.
R133	Resistor	10 kΩ R20
R134	Resistor	10 kΩ R20
R135	Resistor	39 kΩ ELR20
R136	Resistor	47 kΩ ELR20
R137	Resistor	1.5 kΩ ELR20
R138	Resistor	1.5 kΩ R20
R139	Resistor	100 Ω R25
R140	Resistor	22 kΩ R20
R141	Resistor	560 Ω R20
R142	Trimmer	10 kΩ RH0651C14J2WA
R143	Resistor	330 kΩ R20
R144	Trimmer	470 kΩ RH0651CS5J10A
R145	Trimmer	10 kΩ RH0651C14J2WA
R146	Resistor	100 kΩ ELR20
R147	Resistor	220 kΩ ELR20
R149	Resistor	2.2 kΩ ELR20
R150	Resistor	10 kΩ ELR20
R151	Resistor	2.2 kΩ ELR20
R152	Resistor	100 Ω R20
R153	Resistor	150 Ω R20
R154	Resistor	150 Ω R20
R155	Resistor	390 Ω R25
R156	Resistor	390 Ω ELR20
R157	Thermistor	23D29
R158	Resistor	470 kΩ ELR20
R159	Resistor	470 kΩ ELR20
R160	Resistor	22 kΩ ELR20
R161	Resistor	10 kΩ ELR20
R162	Resistor	2.2 kΩ R20
R163	Resistor	220 Ω R20
R164	Resistor	2.2 kΩ R20
R165	Resistor	150 Ω R25
R166	Resistor	2.2 kΩ R20
R167	Resistor	220 Ω R25
R168	Resistor	2.2 kΩ ELR20
R169	Resistor	150 Ω R25
R170	Resistor	2.2 kΩ ELR20
R171	Resistor	470 Ω R20
R172	Resistor	220 Ω R25
R173	Resistor	470 Ω R20
R174	Resistor	2.2 kΩ R20
R175	Resistor	150 Ω R25
R176	Resistor	2.2 kΩ R25
R177	Resistor	220 Ω R25
R178	Resistor	2.2 kΩ R20
R179	Resistor	150 Ω R25
R180	Resistor	100 Ω R20
R181	Resistor	1 kΩ R20
R182	Resistor	4.7 kΩ R20
R183	Resistor	2.2 kΩ R20
R184	Resistor	150 Ω R20
R185	Resistor	150 Ω R20
R186	Trimmer	470 Ω RH0651CS2J1HA
R187	Resistor	56 Ω ELR20
R188	Resistor	10 kΩ R25
R189	Resistor	470 kΩ R20
R190	Resistor	2.2 kΩ ELR20
R191	Resistor	220 Ω R20
R192	Resistor	330 Ω R25
R193	Resistor	220 Ω R20
R194	Resistor	4.7 kΩ ELR20
R195	Resistor	4.7 kΩ ELR20
R196	Resistor	2.2 kΩ R20
R197	Resistor	4.7 kΩ R20
R198	Resistor	220 Ω ELR20
R199	Resistor	220 Ω ELR20
R200	Resistor	4.7 kΩ ELR20
R201	Resistor	2.2 kΩ ELR20
R202	Resistor	4.7 kΩ ELR20
R203	Resistor	330 Ω ELR20
R204	Resistor	220 Ω R20
R205	Resistor	100 Ω ELR20
R206	Trimmer	10 kΩ RH0651C14J2WA
R207	Resistor	220 Ω ELR20
R208	Resistor	2.2 kΩ R20

[IF UNIT]

REF. NO.	DESCRIPTION	PART NO.
R209	Resistor	56 Ω R20
R210	Resistor	1 kΩ R20
R211	Resistor	56 kΩ ELR20
R212	Resistor	330 Ω ELR20
R214	Resistor	15 kΩ R20
R215	Resistor	2.2 kΩ ELR20
R216	Resistor	4.7 kΩ R20
R217	Resistor	100 Ω R25
R218	Resistor	220 Ω R25
R219	Resistor	1.5 kΩ ELR20
R220	Resistor	5.6 kΩ ELR20
R221	Resistor	1 kΩ R25
R222	Resistor	1.5 kΩ ELR20
R223	Resistor	220 Ω R25
R224	Resistor	1.5 kΩ R20
R225	Resistor	5.6 kΩ ELR20
R226	Resistor	150 Ω R25
R227	Resistor	1.5 kΩ R20
R228	Resistor	220 Ω R25
R229	Resistor	1.5 kΩ ELR20
R230	Resistor	5.6 kΩ ELR20
R231	Resistor	150 Ω R25
R232	Resistor	1.5 kΩ R20
R233	Resistor	220 Ω R20
R234	Resistor	1.5 kΩ ELR20
R235	Resistor	5.6 kΩ R20
R236	Resistor	150 Ω R25
R237	Resistor	1.5 kΩ R20
R238	Resistor	220 Ω R20
R239	Resistor	1.5 kΩ R20
R240	Resistor	5.6 kΩ R20
R241	Resistor	150 Ω R20
R242	Resistor	1.5 kΩ ELR20
R243	Resistor	4.7 kΩ R20
R244	Resistor	4.7 kΩ ELR20
R245	Resistor	150 Ω R20
R246	Resistor	4.7 kΩ ELR20
R247	Resistor	100 Ω ELR20
R248	Resistor	4.7 kΩ ELR20
R249	Resistor	100 Ω R20
R250	Trimmer	470 Ω RH0651CS2J1HA
R251	Resistor	56 Ω ELR20
R252	Resistor	120 kΩ R20
R253	Resistor	4.7 kΩ R20
R254	Resistor	2.2 kΩ R20
R255	Resistor	2.2 kΩ R20
R256	Resistor	220 Ω ELR20
R257	Resistor	100 Ω R25
R258	Resistor	1 kΩ ELR20
R259	Resistor	10 kΩ R20
R260	Resistor	100 Ω R20
R261	Resistor	1 kΩ ELR20
R262	Resistor	220 Ω ELR20
R263	Resistor	3.3 kΩ ELR20
R264	Resistor	2.2 kΩ ELR20
R265	Resistor	47 Ω R20
R266	Resistor	56 kΩ ELR20
R267	Resistor	150 Ω R20
R268	Resistor	220 Ω ELR20
R269	Resistor	56 Ω R20
R270	Resistor	10 kΩ ELR20
R271	Resistor	150 Ω R20
R272	Resistor	10 kΩ ELR20
R273	Resistor	330 Ω R20
R274	Resistor	10 kΩ R20
R275	Resistor	56 Ω ELR20
R276	Resistor	10 kΩ R20
R277	Resistor	220 Ω R25
R278	Resistor	330 Ω ELR20
R279	Resistor	2.7 kΩ R25
R280	Resistor	56 Ω ELR20
R281	Resistor	47 kΩ ELR20
R282	Resistor	100 kΩ ELR20
R283	Resistor	47 kΩ R25
R284	Resistor	100 kΩ ELR20

[IF UNIT]

REF. NO.	DESCRIPTION	PART NO.	
R285	Resistor	68 kΩ	ELR20
R286	Resistor	10 kΩ	R20
R287	Resistor	22 kΩ	ELR20
R288	Resistor	10 kΩ	R20
R289	Resistor	5.6 kΩ	R20
R290	Resistor	47 kΩ	R20
R291	Resistor	10 kΩ	ELR20
R292	Resistor	4.7 kΩ	R20
R293	Resistor	470 kΩ	ELR20
R294	Resistor	1.2 kΩ	ELR20
R295	Resistor	47 kΩ	R20
R296	Resistor	4.7 kΩ	R20
R297	Resistor	270 Ω	R20
R298	Resistor	18 Ω	R25
R299	Resistor	270 Ω	R20
R300	Resistor	220 Ω	R25
R301	Resistor	220 Ω	ELR20
R302	Resistor	22 kΩ	ELR20
R303	Resistor	22 kΩ	ELR20
R304	Resistor	1 kΩ	R20
R305	Resistor	1 kΩ	ELR20
R306	Resistor	47 kΩ	R20
R307	Resistor	47 kΩ	ELR20
R308	Resistor	47 kΩ	R20
R309	Resistor	47 kΩ	R20
R310	Resistor	220 kΩ	R20
R311	Resistor	4.7 kΩ	R20
R312	Resistor	10 kΩ	R25
R313	Resistor	100 Ω	R25
R314	Resistor	100 Ω	R25
R315	Resistor	100 Ω	ELR20
R316	Resistor	100 Ω	R20
R317	Resistor	100 Ω	R20
R318	Resistor	100 Ω	R20
R319	Trimmer	4.7 kΩ	RH0651CS3J2KA
R320	Resistor	12 kΩ	R20
R321	Resistor	10 kΩ	R20
R322	Resistor	33 kΩ	R20
R323	Resistor	22 kΩ	R20
R324	Resistor	680 Ω	ELR20
R325	Resistor	4.7 kΩ	R20
R326	Resistor	4.7 kΩ	R25
R327	Resistor	100 kΩ	R20
R328	Resistor	10 kΩ	R20
R329	Thermistor	23D29	
R330	Thermistor	23D29	
R331	Resistor	560 Ω	ELR20
R332	Resistor	220 Ω	R20
R333	Resistor	4.7 kΩ	R20
R334	Trimmer	4.7 kΩ	RH0651CS3J2KA
C1	Electrolytic	10 μF	16 V MS7
C2	Electrolytic	10 μF	16 V MS7
C3	Electrolytic	0.47 μF	50 V MS7
C4	Electrolytic	1 μF	50 V MS7
C5	Electrolytic	0.47 μF	50 V MS7
C6	Tantalum	0.1 μF	35 V DN
C7	Ceramic	0.0047 μF	50 V
C8	Array	0.0047 μF × 6	B7ZC0714-32N
C9	Mylar	0.1 μF	50 V F2D
C11	Mylar	0.1 μF	50 V F2D
C12	Electrolytic	1 μF	50 V MS7
C13	Electrolytic	1 μF	50 V MS7
C14	Ceramic	0.001 μF	50 V
C15	Mylar	0.022 μF	50 V F2D
C16	Barrier Layer	0.1 μF	16 V
C17	Barrier Layer	0.1 μF	16 V
C18	Barrier Layer	0.1 μF	16 V
C19	Electrolytic	3.3 μF	50 V MS7
C20	Barrier Layer	0.1 μF	16 V
C21	Ceramic	100 pF	50 V
C22	Barrier Layer	0.1 μF	16 V
C23	Ceramic	330 pF	50 V
C24	Ceramic	330p μF	50 V

[IF UNIT]

REF. NO.	DESCRIPTION	PART NO.	
C25	Barrier Layer	0.1 μF	16 V
C26	Electrolytic	10 μF	16 V MS7
C27	Electrolytic	100 μF	10 V SS
C28	Electrolytic	10 μF	16 V MS7
C29	Array	0.0082 μF × 7	B8ZC0111-32N
C30	Barrier Layer	0.1 μF	16 V
C31	Electrolytic	100 μF	10 V SS
C32	Barrier Layer	0.0047 μF	25 V
C33	Electrolytic	1 μF	50 V MS7
C34	Barrier Layer	0.1 μF	16 V
C35	Barrier Layer	0.1 μF	16 V
C36	Barrier Layer	0.1 μF	16 V
C37	Electrolytic	22 μF	16 V SS
C38	Mylar	0.1 μF	50 V F2D
C39	Barrier Layer	0.047 μF	25 V
C41	Ceramic	0.0047 μF	50 V
C42	Ceramic	0.0047 μF	50 V
C43	Barrier Layer	0.0047 μF	25 V
C44	Ceramic	0.0047 μF	50 V
C46	Ceramic	0.0047 μF	50 V
C47	Electrolytic	2.2 μF	50 V MS7
C48	Electrolytic	0.47 μF	50 V MS7
C49	Ceramic	0.001 μF	50 V
C50	Ceramic	0.0047 μF	50 V
C51	Electrolytic	10 μF	16 V MS7
C52	Ceramic	470 pF	50 V SL
C53	Ceramic	82 pF	50 V
C54	Ceramic	470 pF	50 V SL
C55	Ceramic	0.0047 μF	50 V
C56	Barrier Layer	0.1 μF	16 V
C57	Ceramic	100 pF	50 V
C58	Ceramic	82 pF	50 V
C59	Ceramic	39 pF	50 V
C60	Cylinder	3.3 pF	UP125SL 3R3K-NA
C61	Electrolytic	1 μF	50 V MS7
C62	Ceramic	0.0047 μF	50 V
C63	Ceramic	0.0047 μF	50 V
C64	Cylinder	0.0047 μF	UP125X 472M-NA
C65	Ceramic	0.0047 μF	50 V
C66	Ceramic	0.0047 μF	50 V
C68	Ceramic	0.0047 μF	50 V
C69	Electrolytic	3.3 μF	50 V MS7
C70	Electrolytic	0.47 μF	50 V MS7
C71	Ceramic	100 pF	50 V
C72	Mylar	0.01 μF	50 V F2D
C73	Ceramic	33 pF	50 V
C74	Mylar	0.001 μF	50 V F2D
C75	Mylar	0.01 μF	50 V F2D
C76	Ceramic	0.001 μF	50 V
C77	Mylar	0.047 μF	50 V F2D
C78	Mylar	0.033 μF	50 V F2D
C79	Ceramic	120 pF	50 V SH
C80	Ceramic	10 pF	50 V
C81	Barrier Layer	0.1 μF	16 V
C82	Barrier Layer	0.1 μF	16 V
C83	Cylinder	0.001 μF	UP125D 102M-NA
C84	Ceramic	0.0047 μF	50 V
C85	Ceramic	0.0047 μF	50 V
C86	Ceramic	0.0047 μF	50 V
C87	Electrolytic	4.7 μF	25 V MS7
C88	Electrolytic	10 μF	16 V MS7
C89	Barrier Layer	0.1 μF	16 V
C90	Barrier Layer	0.1 μF	16 V
C91	Barrier Layer	0.1 μF	16 V
C92	Electrolytic	100 μF	10 V SS
C93	Ceramic	0.0047 μF	50 V
C94	Barrier Layer	0.1 μF	16 V
C96	Barrier Layer	0.1 μF	16 V
C97	Barrier Layer	0.1 μF	16 V
C98	Barrier Layer	0.1 μF	16 V
C99	Mylar	0.047 μF	50 V F2D
C100	Ceramic	150 pF	50 V
C101	Ceramic	150 pF	50 V
C102	Barrier Layer	0.1 μF	16 V
C103	Barrier Layer	0.1 μF	16 V

[IF UNIT]

REF. NO.	DESCRIPTION	PART NO.	
C104	Barrier Layer	0.1 μF	16 V
C105	Barrier Layer	0.1 μF	16 V
C106	Barrier Layer	0.1 μF	16 V
C107	Barrier Layer	0.1 μF	16 V
C108	Barrier Layer	0.1 μF	16 V
C109	Barrier Layer	0.1 μF	16 V
C110	Barrier Layer	0.1 μF	16 V
C111	Ceramic	470 pF	50 V SL
C112	Barrier Layer	0.1 μF	16 V
C113	Barrier Layer	0.1 μF	16 V
C114	Barrier Layer	0.1 μF	16 V
C115	Barrier Layer	0.1 μF	16 V
C116	Ceramic	470 pF	50 V SL
C117	Barrier Layer	0.1 μF	16 V
C118	Barrier Layer	0.1 μF	16 V
C119	Ceramic	0.0047 μF	50 V
C120	Barrier Layer	0.1 μF	16 V
C121	Barrier Layer	0.1 μF	16 V
C122	Ceramic	0.0047 μF	50 V
C123	Ceramic	0.0047 μF	50 V
C124	Barrier Layer	0.1 μF	16 V
C125	Barrier Layer	0.1 μF	16 V
C126	Barrier Layer	0.1 μF	16 V
C127	Ceramic	0.0047 μF	50 V
C128	Barrier Layer	0.1 μF	16 V
C129	Ceramic	0.0047 μF	50 V
C130	Ceramic	150 pF	50 V
C131	Barrier Layer	0.1 μF	16 V
C132	Barrier Layer	0.1 μF	16 V
C133	Barrier Layer	0.1 μF	16 V
C134	Ceramic	220 pF	50 V
C135	Electrolytic	0.1 μF	50 V MS7
C137	Barrier Layer	0.1 μF	16 V
C138	Barrier Layer	0.1 μF	16 V
C139	Ceramic	0.0047 μF	50 V
C141	Barrier Layer	0.1 μF	16 V
C142	Ceramic	0.0047 μF	50 V
C143	Cylinder	0.0047 μF	UP125X 472M-NA
C145	Ceramic	0.0047 μF	50 V
C146	Barrier Layer	0.047 μF	25 V
C147	Ceramic	0.0047 μF	50 V
C148	Ceramic	0.0047 μF	50 V
C149	Barrier Layer	0.047 μF	25 V
C150	Barrier Layer	0.047 μF	25 V
C151	Ceramic	0.0047 μF	50 V
C152	Ceramic	0.0047 μF	50 V
C153	Barrier Layer	0.047 μF	25 V
C154	Barrier Layer	0.047 μF	25 V
C155	Ceramic	0.0047 μF	50 V
C156	Ceramic	0.0047 μF	50 V
C157	Barrier Layer	0.047 μF	25 V
C158	Barrier Layer	0.047 μF	25 V
C159	Ceramic	0.0047 μF	50 V
C160	Ceramic	0.0047 μF	50 V
C161	Barrier Layer	0.047 μF	25 V
C162	Barrier Layer	0.047 μF	25 V
C163	Barrier Layer	0.047 μF	25 V
C164	Barrier Layer	0.047 μF	25 V
C165	Ceramic	0.0047 μF	50 V
C166	Ceramic	0.0047 μF	50 V
C167	Electrolytic	100 μF	10 V SS
C168	Ceramic	0.0047 μF	50 V
C170	Barrier Layer	0.1 μF	16 V
C171	Barrier Layer	0.047 μF	25 V
C174	Ceramic	0.0047 μF	50 V
C175	Ceramic	0.0047 μF	50 V
C177	Ceramic	150 pF	50 V
C178	Ceramic	0.0047 μF	50 V
C179	Ceramic	0.0047 μF	50 V
C180	Ceramic	300 pF	50 V
C181	Ceramic	470 pF	50 V SL
C183	Ceramic	330 pF	50 V
C184	Ceramic	100 pF	50 V
C185	Ceramic	0.0047 μF	50 V
C187	Ceramic	0.0047 μF	50 V

[IF UNIT]

REF. NO.	DESCRIPTION	PART NO.	
C188	Ceramic	0.001 μF	50 V
C190	Ceramic	0.0047 μF	50 V
C191	Ceramic	0.0047 μF	50 V
C192	Ceramic	0.0047 μF	50 V
C193	Ceramic	0.0047 μF	50 V
C194	Ceramic	0.001 μF	50 V
C196	Ceramic	0.0047 μF	50 V
C197	Ceramic	0.0047 μF	50 V
C198	Ceramic	0.0047 μF	50 V
C200	Ceramic	5 pF	50 V
C201	Mylar	0.047 μF	50 V F2D
C202	Mylar	0.0047 μF	50 V F2D
C203	Electrolytic	2.2 μF	50 V MS7
C204	Electrolytic	1 μF	50 V MS7
C205	Electrolytic	4.7 μF	25 V MS7
C206	Electrolytic	10 μF	16 V MS7
C207	Tantalum	0.68 μF	35 V DN
C208	Mylar	0.01 μF	50 V F2D
C209	Ceramic	15 pF	50 V
C210	Barrier Layer	0.75 pF	50 V
C211	Ceramic	15 pF	50 V
C212	Ceramic	0.0047 μF	50 V
C213	Ceramic	0.0047 μF	50 V
C214	Ceramic	0.001 μF	50 V
C215	Ceramic	0.001 μF	50 V
C216	Electrolytic	10 μF	16 V MS7
C217	Electrolytic	100 μF	16 V SS
C218	Electrolytic	10 μF	16 V MS7
C219	Electrolytic	10 μF	16 V MS7
C220	Electrolytic	10 μF	16 V MS7
C221	Ceramic	0.0047 μF	50 V
C222	Electrolytic	10 μF	16 V MS7
C223	Ceramic	0.0047 μF	50 V
C224	Ceramic	0.0047 μF	50 V
C225	Electrolytic	10 μF	16 V MS7
C226	Ceramic	0.0047 μF	50 V
C227	Electrolytic	10 μF	16 V MS7
C228	Ceramic	0.0047 μF	50 V
C229	Electrolytic	10 μF	16 V MS7
C230	Ceramic	0.0047 μF	50 V
C231	Electrolytic	10 μF	16 V MS7
C232	Ceramic	330 pF	50 V
C233	Ceramic	330 pF	50 V
C234	Ceramic	0.001 μF	50 V
C235	Barrier Layer	0.1 μF	16 V
C236	Barrier Layer	0.1 μF	16 V
C238	Electrolytic	100 μF	10 V SS
C239	Ceramic	0.0047 μF	50 V
C240	Mylar	0.0047 μF	50 V F2D
C241	Barrier Layer	0.1 μF	16 V
C242	Ceramic	33 pF	50 V
J1	Connector	TL25P-08-V1	
J2	Connector	TL25P-07-V1	
J3	Connector	TL25P-04-V1	
J4	Connector	TL25P-04-V1	
J5	Connector	TL25P-06-V1	
J6	Connector	TL25P-06-V1	
J7	Connector	TL25P-05-V1	
J8	Connector	TL25P-04-V1	
J9	Connector	TL25P-06-V1	
J10	Connector	TL25P-03-V1	
J11	Connector	TL25P-05-V1	
J12	Connector	TL25P-04-V1	
J13	Connector	TMP-J01X-A2	
J14	Connector	TL25P-05-V1	
J16	Connector	TLB-P04H-B1	
P1	Connector	TL25H-07-B1	
P2	Connector	TMP-P01X-A1	
P3	Connector	TL25H-10-B1	
P4	Connector	TMP-P01X-A1	
P5	Connector	TMP-P01X-A1	



[IF UNIT]

REF. NO.	DESCRIPTION	PART NO.
P6	Connector	TMP-P01X-A1
S1	Switch	SSSS31124A (SSB FILTER)
S2	Switch	SSSS31124A (AM FILTER)
S5	Switch	SSSS31124A (150/50 W)
SO5	Socket	50864-1
SO6	Socket	50864-1
SO7	Socket	50864-1
SO8	Socket	50864-1
EP1	P.C. Board	B-1330B

[VOX UNIT]

REF. NO.	DESCRIPTION	PART NO.
C1	Ceramic	0.1 $\mu$ F GRM40 F
C2	Tantalum	1 $\mu$ F 16 V SV
C3	Ceramic	0.1 $\mu$ F GRM40 F
C4	Ceramic	0.1 $\mu$ F GRM40 F
C5	Tantalum	1 $\mu$ F 16 V SV
J1	Connector	50002-8106
J2	Connector	50002-8105
EP1	P.C. Board	B-1333A

[VOX UNIT]

REF. NO.	DESCRIPTION	PART NO.
IC1	IC	NJM4558M
IC2	IC	LA6393M
Q1	Transistor	RN1404
Q2	Transistor	RN1404
Q3	Transistor	RN2404
Q4	Transistor	RN2404
D1	Diode	1SS193
D2	Diode	1SS193
D3	Diode	1SS226
D4	Diode	1SS193
D5	Diode	1SS193
R1	Resistor	4.7 k $\Omega$ MCR10
R2	Resistor	100 k $\Omega$ MCR10
R3	Resistor	47 k $\Omega$ MCR10
R4	Resistor	47 k $\Omega$ MCR10
R5	Resistor	47 k $\Omega$ MCR10
R6	Resistor	22 k $\Omega$ MCR10
R7	Resistor	10 k $\Omega$ MCR10
R8	Resistor	1 k $\Omega$ MCR10
R9	Resistor	47 k $\Omega$ MCR10
R10	Resistor	10 k $\Omega$ MCR10
R11	Resistor	4.7 k $\Omega$ MCR10
R12	Resistor	47 k $\Omega$ MCR10
R13	Resistor	47 k $\Omega$ MCR10
R14	Resistor	47 k $\Omega$ MCR10
R15	Resistor	10 k $\Omega$ MCR10
R16	Resistor	10 k $\Omega$ MCR10
R17	Resistor	10 k $\Omega$ MCR10
R18	Resistor	1 k $\Omega$ MCR10
R19	Resistor	1 k $\Omega$ MCR10
R20	Resistor	5.6 k $\Omega$ MCR10
R21	Resistor	2.2 k $\Omega$ MCR10

[SWR UNIT]

REF. NO.	DESCRIPTION	PART NO.
IC1	IC	NJM4558M
IC2	IC	NJM4558M
Q1	FET	2SK209 Y
Q2	FET	2SK209 Y
D1	Diode	1SS187
R1	Resistor	100 k $\Omega$ MCR10
R2	Resistor	10 k $\Omega$ MCR10
R3	Resistor	10 k $\Omega$ MCR10
R4	Resistor	10 k $\Omega$ MCR10
R5	Resistor	68 k $\Omega$ MCR10
R6	Resistor	39 k $\Omega$ MCR10
R7	Resistor	47 k $\Omega$ MCR10
R8	Resistor	47 k $\Omega$ MCR10
R9	Resistor	22 k $\Omega$ MCR10
R10	Resistor	100 k $\Omega$ MCR10
R11	Resistor	10 k $\Omega$ MCR10
R12	Resistor	10 k $\Omega$ MCR10
R13	Resistor	120 k $\Omega$ MCR10
R14	Resistor	10 k $\Omega$ MCR10
R15	Resistor	6.8 k $\Omega$ MCR10
R16	Resistor	10 k $\Omega$ MCR10
R17	Resistor	39 k $\Omega$ MCR10
R18	Resistor	1 M $\Omega$ MCR10
R19	Resistor	39 k $\Omega$ MCR10
C1	Ceramic	0.047 $\mu$ F GRM40
C2	Ceramic	0.01 $\mu$ F GRM40 F
C3	Ceramic	0.047 $\mu$ F GRM40
C4	Ceramic	0.047 $\mu$ F GRM40
C5	Ceramic	0.047 $\mu$ F GRM40
C6	Ceramic	470 pF GRM40
C7	Ceramic	0.0056 $\mu$ F GRM40
J1	Connector	50002-8104
J2	Connector	50002-8103
EP1	P.C. Board	B-1332A

[CM UNIT]

REF. NO.	DESCRIPTION	PART NO.	
IC1	IC	NJM4558M	
IC2	IC	LA6393M	
R1	Resistor	100 kΩ	MCR10
R2	Resistor	100 kΩ	MCR10
R3	Resistor	100 kΩ	MCR10
R4	Resistor	100 kΩ	MCR10
R5	Resistor	10 kΩ	MCR10
R6	Resistor	100 kΩ	MCR10
R7	Resistor	100 kΩ	MCR10
R8	Resistor	100 kΩ	MCR10
R9	Resistor	100 kΩ	MCR10
R10	Resistor	10 kΩ	MCR10
C1	Ceramic	0.1 μF	GRM40 F
C2	Ceramic	0.1 μF	GRM40 F
J1	Connector	50002-8109	
EP1	P.C. Board	B-1331B	

[RF UNIT]

REF. NO.	DESCRIPTION	PART NO.	
IC1	IC	M54562P	
IC2	IC	M54562P	
Q1	Transistor	2SB562 C	
Q2	Transistor	RN1202	
Q3	Transistor	RN1204	
Q5	Transistor	2SC2458	GR
Q6	Transistor	2SC2458	GR
Q7	FET	2SK125	
Q8	FET	2SK125	
Q9	FET	3SK74	M
Q10	FET	2SK241 Y	
Q11	Transistor	2SA1048 Y	
Q12	Transistor	2SC1571 G	
Q13	FET	2SK125	
Q14	FET	2SK125	
Q15	Transistor	RN1202	
Q16	Transistor	2SA1048 Y	
Q17	Transistor	RN1204	
Q18	Transistor	RN1202	
Q19	Transistor	RN2202	
Q20	Transistor	2SC2053	
Q21	FET	3SK74	M
Q22	FET	2SK241 Y	
Q23	FET	3SK74	M
Q24	FET	3SK74	K
Q25	FET	3SK74	K
Q26	Transistor	RN1204	
Q27	Transistor	RN1204	
Q28	Transistor	RN1204	
Q301	Transistor	2SA1048 Y	
Q302	FET	2SK125	
Q303	FET	2SK125	
Q304	FET	2SK125	
Q305	Transistor	2SC2053	
Q401	Transistor	2SA1048 Y	
Q402	FET	2SK125	
Q403	FET	2SK125	

[RF UNIT]

REF. NO.	DESCRIPTION	PART NO.	
Q404	FET	2SK125	
Q405	Transistor	2SC2053	
D1	Diode	1SS133	
D2	Diode	1SS133	
D5	Diode	1SS133	
D6	Diode	1SS133	
D7	Zener	RD7.5E B2	
D8	Diode	1SS53	
D9	Diode	1SS53	
D10	Diode	1SS53	
D11	Diode	1SS53	
D12	Diode	1SS53	
D13	Diode	1SS53	
D14	Diode	1SS53	
D15	Diode	1SS53	
D16	Diode	1SS53	
D17	Diode	1SS53	
D18	Diode	MI204	
D19	Diode	MI204	
D20	Diode	MI204	
D21	Diode	MI204	
D22	Diode	MI204	
D23	Diode	MI204	
D24	Diode	1SS53	
D25	Diode	1SS53	
D26	Diode	1SS53	
D27	Diode	1SS53	
D28	Diode	1SS53	
D29	Diode	1SS53	
D30	Diode	1SS53	
D31	Diode	1SS53	
D32	Diode	1SS53	
D33	Diode	1SS53	
D34	Diode	1SS53	
D35	Diode	1SS53	
D36	Diode	1SS53	
D37	Diode	1SS53	
D38	Diode	1SS53	
D39	Diode	1SS53	
D40	Diode	1SS53	
D41	Diode	1SS53	
D42	Diode	MI204	
D43	Diode	1SS53	
D44	Diode	1SS53	
D45	Diode	1SS53	
D46	Diode	1SS133	
D47	Diode	1SS216	
D48	Diode	1SS53	
D49	Diode	1SS216	
D50	Diode	1SS53	
D51	Diode	1SS133	
D301	Diode	MI204	
D302	Diode	MI204	
D303	Diode	MI204	
D304	Diode	MI204	
D305	Diode	MI204	
D401	Diode	MI204	
D402	Diode	MI204	
D403	Diode	MI204	
D404	Diode	MI204	
D405	Diode	MI204	
Fl1	Monolithic	FL-90	
L1	Coil	LAL03NA 101K	
L2	Coil	LAL03NA 101K	
L3	Coil	LAL03NA 101K	
L4	Coil	LAL03NA 101K	
L5	Coil	LAL03NA 101K	
L8	Coil	LAL04NA 101K	
L9	Coil	LAL03NA 561K	

## [RF UNIT]

REF. NO.	DESCRIPTION	PART NO.
L10	Coil	LAL03NA 561K
L11	Coil	LAL03NA 561K
L12	Coil	LAL03NA 561K
L13	Coil	LAL03NA 561K
L14	Coil	LAL03NA 101K
L15	Coil	LAL04NA 102K
L16	Coil	FL9H 471K
L17	Coil	LAL03NA 101K
L18	Coil	LAL03NA 101K
L20	Coil	LAL03NA 100K
L21	Coil	LAL03NA 100K
L22	Coil	LAL03NA 100K
L23	Coil	LAL03NA 100K
L24	Coil	LR-85A
L25	Coil	LAL03NA 100K
L26	Coil	LAL03NA 100K
L27	Coil	LAL03NA 100K
L28	Coil	LAL03NA 100K
L30	Coil	LS-306
L31	Coil	LS-306
L32	Coil	LS-114
L33	Coil	LS-306
L34	Coil	LS-306
L35	Coil	LS-114
L36	Coil	LR-86
L37	Coil	LR-86
L38	Coil	LAL03NA R56M
L39	Coil	LAL03NA R56M
L40	Coil	LAL03NA R47M
L41	Coil	LR-163
L42	Coil	LAL03NA R56M
L43	Coil	LAL03NA R56M
L44	Coil	LAL03NA R47M
L45	Coil	S4 102K
L46	Coil	LAL03NA 102K
L47	Coil	LAL03NA 102K
L48	Coil	LAL03NA 561K
L49	Coil	LAL03NA 561K
L50	Coil	LAL03NA 561K
L51	Coil	LAL03NA 561K
L52	Coil	LAL03NA 561K
L53	Coil	LR-130
L54	Coil	LAL03NA 4R7K
L55	Coil	LAL03NA 4R7K
L56	Coil	LR-129
L57	Coil	S4 220K
L58	Coil	S4 220K
L59	Coil	S4 102K
L60	Coil	LAL03NA 102K
L61	Coil	LB4 6R2J
L62	Coil	LB4 5R1J
L63	Coil	LAL03NA 102K
L65	Coil	LB4 5R1J
L66	Coil	LB4 6R2J
L67	Coil	LAL03NA 102K
L68	Coil	EL0606SKI-2R7K
L69	Coil	EL0606SKI-3R3K
L70	Coil	EL0606SKI-3R3K
L71	Coil	LB4 4R3J
L72	Coil	LAL03NA 561K
L73	Coil	EL0606SKI-1R8K
L74	Coil	EL0606SKI-1R8K
L75	Coil	EL0606SKI-2R2K
L76	Coil	EL0606SKI-2R7K
L77	Coil	LAL03NA 561K
L78	Coil	EL0606SKI-1R5K
L79	Coil	EL0606SKI-1R5K
L80	Coil	EL0606SKI-1R5K
L81	Coil	EL0606SKI-1R8K
L82	Coil	LAL03NA 101K
L83	Coil	EL0606SKI-1R0K
L84	Coil	EL0606SKI-1R2K
L85	Coil	EL0606SKI-1R2K
L86	Coil	EL0606SKI-1R2K
L87	Coil	LAL03NA 101K

## [RF UNIT]

REF. NO.	DESCRIPTION	PART NO.
L88	Coil	LB4 R70K
L89	Coil	LB4 R83K
L90	Coil	EL0606SKI-1R0K
L91	Coil	EL0606SKI-1R0K
L92	Coil	LAL03NA 101K
L93	Coil	LB4 R54K
L94	Coil	LB4 R65K
L95	Coil	LB4 R65K
L96	Coil	LB4 R83K
L97	Coil	LAL03NA 101K
L98	Coil	LB4 R45K
L99	Coil	LB4 R50K
L100	Coil	LB4 R50K
L101	Coil	LB4 R54K
L102	Coil	LAL03NA 101K
L103	Coil	LB4 R34K
L104	Coil	LB4 R36K
L105	Coil	LB4 R30K
L106	Coil	LB4 R36K
L107	Coil	LAL03NA 101K
L109	Coil	LAL03NA 102K
L110	Coil	LAL03NA 102K
L111	Coil	LAL03NA 4R7K
L112	Coil	LAL03NA 6R8K
L114	Coil	S4 102K
L115	Coil	LAL03NA 561K
L116	Coil	S4 102K
L117	Coil	LAL03NA 102K
L118	Coil	LR-19
L119	Coil	LAL04NA 102K
L120	Coil	LAL03NA 561K
L121	Coil	LAL03NA 561K
L122	Coil	LAL03NA 101K
L123	Coil	LAL03NA 561K
L124	Coil	LR-18
L125	Coil	LAL03NA 101K
L126	Coil	LS-114
L127	Coil	LS-114
L128	Coil	LS-198
L129	Coil	LR-116
L130	Coil	LAL03NA 1R0M
L131	Coil	LAL03NA R68M
L132	Coil	LAL03NA 100K
L133	Coil	LAL03NA 561K
L134	Coil	LAL03NA 5R6K
L135	Coil	LAL03NA 101K
L137	Coil	BT01RN1-A61
L138	Coil	LAL03NA R22M
L139	Coil	S4 102K
L140	Coil	LAL03NA 101K
L141	Coil	LAL03NA 101K
L301	Coil	LAL03NA 100K
L302	Coil	LAL03NA 100K
L303	Coil	LAL03NA 100K
L304	Coil	LAL03NA 100K
L305	Coil	LAL03NA 100K
L306	Coil	LS-309
L307	Coil	LAL03NA 100K
L308	Coil	LR-184
L309	Coil	LAL03NA 102K
L310	Coil	LAL03NA 1R5M
L311	Coil	S4 102K
L312	Coil	LAL04NA 101K
L313	Coil	LAL03NA R47M
L314	Coil	LAL03NA R33M
L315	Coil	LAL03NA 2R2M
L316	Coil	LAL03NA 100K
L317	Coil	LAL03NA R22M
L318	Coil	LA-247
L319	Coil	LAL03NA 100K
L401	Coil	LAL03NA 100K
L402	Coil	LAL03NA 100K
L403	Coil	LAL03NA 100K
L404	Coil	LAL03NA 100K
L405	Coil	LAL03NA 100K

## [RF UNIT]

REF. NO.	DESCRIPTION	PART NO.
L406	Coil	LS-309
L407	Coil	LAL03NA 100K
L408	Coil	LR-184
L409	Coil	LAL03NA 102K
L410	Coil	LAL03NA 1R5M
L411	Coil	S4 102K
L412	Coil	LAL04NA 101K
L413	Coil	LAL03NA R47M
L414	Coil	LAL03NA R33M
L415	Coil	LAL03NA 2R2M
L416	Coil	LAL03NA 100K
L417	Coil	LAL03NA R22M
L418	Coil	LAL03NA R33M
L419	Coil	LAL03NA 100K
R1	Resistor	2.2 Ω R20
R2	Resistor	6.8 kΩ ELR20
R3	Resistor	22 kΩ ELR20
R4	Array	47 kΩ RMX-8
R5	Resistor	4.7 kΩ ELR20
R6	Resistor	4.7 kΩ ELR20
R7	Resistor	4.7 kΩ ELR20
R8	Resistor	4.7 kΩ ELR20
R9	Resistor	4.7 kΩ ELR20
R10	Resistor	330 Ω ELR20
R11	Resistor	4.7 kΩ ELR20
R12	Resistor	4.7 kΩ ELR20
R13	Resistor	4.7 kΩ ELR20
R14	Resistor	4.7 kΩ ELR20
R15	Resistor	4.7 kΩ ELR20
R16	Resistor	4.7 kΩ ELR20
R17	Resistor	4.7 kΩ ELR20
R18	Array	47 kΩ RMX-8
R20	Resistor	10 kΩ ELR20
R21	Resistor	22 kΩ ELR20
R22	Resistor	47 Ω ELR20
R23	Resistor	47 Ω ELR20
R24	Resistor	820 Ω ELR20
R25	Resistor	100 Ω ELR20
R26	Resistor	1.5 kΩ ELR20
R27	Resistor	820 Ω ELR20
R28	Resistor	100 Ω R20
R29	Resistor	2.2 kΩ R20
R30	Resistor	2.2 kΩ R20
R31	Resistor	2.2 kΩ ELR20
R32	Resistor	220 Ω ELR20
R33	Resistor	100 Ω ELR20
R34	Resistor	470 kΩ R20
R35	Resistor	47 Ω ELR20
R36	Resistor	5.6 kΩ ELR20
R37	Resistor	100 kΩ ELR20
R38	Resistor	220 Ω ELR20
R39	Resistor	2.2 kΩ R20
R40	Resistor	270 Ω R20
R41	Resistor	18 Ω ELR20
R42	Resistor	270 Ω ELR20
R43	Resistor	47 kΩ ELR20
R44	Resistor	2.2 kΩ ELR20
R45	Resistor	180 Ω R20
R46	Resistor	470 Ω ELR20
R47	Resistor	12 kΩ R20
R48	Resistor	10 kΩ ELR20
R49	Resistor	2.2 kΩ ELR20
R50	Trimmer	2.2 kΩ RH0651CJ3J0CA
R51	Resistor	22 kΩ ELR20
R52	Resistor	10 kΩ R20
R53	Resistor	47 Ω ELR20
R54	Resistor	47 Ω ELR20
R55	Resistor	100 Ω ELR20
R56	Resistor	47 Ω ELR20
R57	Resistor	100 Ω R20
R58	Resistor	220 Ω R20
R59	Resistor	100 Ω ELR20
R60	Resistor	47 Ω ELR20

## [RF UNIT]

REF. NO.	DESCRIPTION	PART NO.
R61	Resistor	47 Ω R20
R62	Resistor	470 Ω ELR20
R63	Resistor	100 Ω ELR20
R64	Resistor	100 Ω R20
R65	Resistor	100 Ω ELR20
R66	Resistor	68 Ω R20
R67	Resistor	100 Ω R20
R68	Resistor	100 Ω R20
R69	Resistor	100 Ω R20
R70	Resistor	100 Ω R20
R71	Resistor	100 Ω R20
R72	Resistor	100 Ω R20
R73	Resistor	100 Ω R20
R74	Resistor	100 Ω R20
R75	Resistor	100 Ω R20
R76	Resistor	100 Ω R20
R77	Resistor	470 Ω R20
R80	Resistor	470 Ω ELR20
R81	Resistor	56 Ω ELR20
R82	Resistor	120 Ω ELR20
R83	Resistor	82 Ω ELR20
R84	Resistor	10 kΩ ELR20
R85	Resistor	120 Ω ELR20
R86	Resistor	120 Ω ELR20
R87	Resistor	120 Ω ELR20
R88	Resistor	2.2 kΩ R20
R89	Resistor	2.2 kΩ ELR20
R90	Resistor	4.7 kΩ ELR20
R91	Resistor	10 kΩ ELR20
R92	Resistor	2.2 kΩ ELR20
R93	Resistor	2.2 kΩ ELR20
R94	Resistor	2.2 kΩ ELR20
R95	Resistor	10 kΩ ELR20
R96	Resistor	27 Ω R20
R97	Resistor	4.7 kΩ ELR20
R98	Resistor	220 Ω ELR20
R99	Resistor	4.7 Ω ELR20
R100	Resistor	10 kΩ R20
R101	Resistor	10 kΩ R20
R102	Resistor	68 Ω R20
R103	Resistor	220 Ω ELR20
R104	Resistor	220 Ω ELR20
R105	Resistor	150 Ω R20
R106	Resistor	27 Ω R20
R107	Resistor	100 kΩ ELR20
R108	Resistor	220 Ω ELR20
R109	Resistor	220 Ω R25
R110	Resistor	2.2 kΩ R20
R111	Resistor	1 kΩ R25
R112	Resistor	1.5 kΩ ELR20
R113	Resistor	220 Ω ELR20
R114	Resistor	100 Ω ELR20
R115	Resistor	22 kΩ R20
R116	Resistor	100 Ω ELR20
R117	Thermistor	23D29
R118	Resistor	470 Ω ELR20
R119	Resistor	100 Ω ELR20
R120	Resistor	47 Ω ELR20
R121	Resistor	22 kΩ R20
R122	Resistor	1 kΩ ELR20
R123	Resistor	1 kΩ ELR20
R124	Resistor	100 Ω R20
R125	Resistor	220 Ω R20
R126	Resistor	100 Ω R25
R127	Resistor	2.2 kΩ ELR20
R128	Resistor	8.2 Ω ELR20
R129	Resistor	150 Ω ELR20
R130	Resistor	8.2 Ω ELR20
R132	Thermistor	23D29
R133	Thermistor	23D29
R134	Resistor	390 Ω ELR20
R135	Resistor	1 kΩ R20
R136	Resistor	3.3 kΩ R20
R137	Resistor	3.3 kΩ R25
R138	Resistor	5.6 kΩ R20



[RF UNIT]

REF. NO.	DESCRIPTION	PART NO.
R139	Resistor	22 Ω ELR20
R140	Trimmer	330 Ω RH0651CN2J02A
R301	Resistor	8.2 kΩ ELR20
R302	Resistor	18 kΩ ELR20
R303	Resistor	4.7 kΩ R20
R304	Resistor	27 kΩ ELR20
R305	Resistor	12 Ω R20
R306	Resistor	2.2 kΩ R20
R307	Resistor	220 Ω R20
R308	Resistor	820 Ω R20
R309	Resistor	47 Ω R20
R310	Resistor	10 kΩ ELR20
R311	Resistor	220 Ω ELR20
R312	Resistor	560 Ω ELR20
R313	Resistor	560 Ω R20
R314	Resistor	100 Ω ELR25
R315	Resistor	22 Ω ELR20
R316	Resistor	5.6 kΩ ELR20
R317	Resistor	820 Ω R20
R318	Resistor	100 Ω ELR20
R319	Resistor	1 kΩ ELR20
R320	Resistor	1.2 kΩ ELR20
R321	Resistor	68 Ω R20
R322	Trimmer	4.7 kΩ RH0651CS3J2KA
R401	Resistor	8.2 kΩ ELR20
R402	Resistor	18 kΩ ELR20
R403	Resistor	4.7 kΩ R20
R404	Resistor	27 kΩ ELR20
R405	Resistor	12 kΩ R20
R406	Resistor	2.2 kΩ R20
R407	Resistor	220 Ω R20
R409	Resistor	47 Ω R20
R410	Resistor	10 kΩ ELR20
R411	Resistor	180 Ω ELR20
R412	Resistor	560 Ω ELR20
R413	Resistor	560 Ω R20
R414	Resistor	100 Ω ELR25
R415	Resistor	22 Ω ELR20
R416	Resistor	5.6 kΩ ELR20
R417	Resistor	820 Ω R20
R418	Resistor	100 Ω ELR20
R419	Resistor	1 kΩ ELR20
R420	Resistor	1.2 kΩ ELR20
R421	Resistor	68 Ω R20
R422	Trimmer	4.7 kΩ RH0651CS3J2KA
C1	Barrier Layer	0.047 μF 25 V
C2	Ceramic	0.001 μF 50 V
C3	Array	0.0082 μF × 7 B8ZC0111-32N
C4	Array	0.0082 μF × 7 B8ZC0111-32N
C5	Array	0.0082 μF × 7 B8ZC0111-32N
C6	Array	0.0082 μF × 7 B8ZC0111-32N
C7	Barrier Layer	0.047 μF 25 V
C8	Ceramic	0.0047 μF 50 V
C9	Ceramic	0.0047 μF 50 V
C10	Ceramic	0.0047 μF 50 V
C11	Ceramic	0.001 μF 50 V
C12	Ceramic	0.0047 μF 50 V
C13	Ceramic	0.0047 μF 50 V
C14	Ceramic	0.0047 μF 50 V
C15	Ceramic	0.0047 μF 50 V
C16	Ceramic	0.001 μF 50 V
C17	Ceramic	8 pF 50 V
C18	Ceramic	8 pF 50 V
C19	Ceramic	0.0047 μF 50 V
C20	Ceramic	0.0047 μF 50 V
C21	Ceramic	15 pF 50 V
C22	Ceramic	0.0047 μF 50 V
C23	Ceramic	0.0047 μF 50 V
C24	Mylar	0.022 μF 50 V F2D
C25	Ceramic	0.0047 μF 50 V
C26	Ceramic	0.001 μF 50 V
C27	Ceramic	3 pF 50 V
C28	Ceramic	6 pF 50 V

[RF UNIT]

REF. NO.	DESCRIPTION	PART NO.
C29	Ceramic	0.0047 μF 50 V
C30	Ceramic	15 pF 50 V
C31	Ceramic	0.0047 μF 50 V
C32	Ceramic	56 pF 50 V
C33	Ceramic	13 pF 50 V
C34	Ceramic	68 pF 50 V
C35	Ceramic	27 pF 50 V
C36	Ceramic	68 pF 50 V
C37	Ceramic	56 pF 50 V
C38	Ceramic	13 pF 50 V
C39	Ceramic	68 pF 50 V
C40	Ceramic	27 pF 50 V
C41	Ceramic	68 pF 50 V
C42	Ceramic	220 pF 50 V
C43	Electrolytic	2.2 μF 50 V RC2
C44	Barrier Layer	0.047 μF 25 V
C45	Barrier Layer	0.047 μF 25 V
C46	Barrier Layer	0.047 μF 25 V
C47	Barrier Layer	0.1 μF 16 V
C48	Barrier Layer	0.1 μF 16 V
C49	Barrier Layer	0.047 μF 25 V
C50	Barrier Layer	0.047 μF 25 V
C51	Barrier Layer	0.047 μF 25 V
C52	Barrier Layer	0.047 μF 25 V
C53	Barrier Layer	0.047 μF 25 V
C54	Barrier Layer	0.047 μF 25 V
C55	Barrier Layer	0.047 μF 25 V
C56	Barrier Layer	0.047 μF 25 V
C57	Barrier Layer	0.0068 μF 25 V UAT06V 682K
C58	Barrier Layer	0.001 μF 25 V UAT04V 102K
C59	Barrier Layer	0.0082 μF 25 V UAT06V 822K
C60	Barrier Layer	0.1 μF 16 V
C61	Electrolytic	10 μF 25 V SS
C62	Barrier Layer	0.1 μF 16 V
C63	Barrier Layer	0.1 μF 16 V
C64	Barrier Layer	0.0033 μF 25 V UAT05V 332K
C65	Ceramic	390 pF 50 V
C66	Barrier Layer	0.0033 μF 25 V UAT05V 332K
C67	Barrier Layer	0.1 μF 16 V
C68	Barrier Layer	0.047 μF 25 V
C71	Barrier Layer	0.047 μF 25 V
C72	Barrier Layer	0.0022 μF 25 V UAT04V 222K
C73	Ceramic	270 pF 50 V
C74	Barrier Layer	0.0022 μF 25 V UAT04V 222K
C75	Barrier Layer	0.047 μF 25 V
C76	Barrier Layer	0.047 μF 25 V
C77	Barrier Layer	0.0012 μF 25 V UAT04V 122K
C78	Barrier Layer	0.01 μF 25 V UAT06V 103K
C79	Barrier Layer	0.0018 μF 25 V UAT04V 182K
C80	Barrier Layer	0.001 μF 25 V UAT04V 102K
C81	Ceramic	200 pF 50 V
C82	Barrier Layer	0.0015 μF 25 V UAT04V 152K
C83	Barrier Layer	0.047 μF 25 V
C84	Barrier Layer	0.047 μF 25 V
C85	Barrier Layer	0.001 μF 25 V UAT04V 102K
C86	Barrier Layer	0.0068 μF 25 V UAT06V 682K
C87	Barrier Layer	0.0012 μF 25 V UAT04V 122K
C88	Barrier Layer	0.001 μF 25 V UAT04V 102K
C89	Ceramic	100 pF 50 V
C90	Barrier Layer	0.0015 μF 25 V UAT04V 152K
C91	Barrier Layer	0.047 μF 25 V
C92	Barrier Layer	0.047 μF 25 V
C93	Barrier Layer	560 pF 50 V RAU06SA 561K
C94	Barrier Layer	0.0056 μF 25 V UAT06V 562K
C95	Barrier Layer	0.001 μF 25 V UAT04V 102K
C96	Barrier Layer	680 pF 50 V RAU06SA 681K
C97	Ceramic	100 pF 50 V
C98	Barrier Layer	680 pF 50 V RAU06SA 681K
C99	Barrier Layer	0.047 μF 25 V
C100	Barrier Layer	0.047 μF 25 V
C101	Ceramic	390 pF 50 V
C102	Barrier Layer	0.0027 μF 25 V 272K UAT05V
C103	Ceramic	470 pF 50 V SL
C104	Ceramic	390 pF 50 V
C105	Ceramic	75 pF 50 V

## [RF UNIT]

REF. NO.	DESCRIPTION	PART NO.
C106	Barrier Layer	560 pF 50 V RAU06SA 561K
C107	Barrier Layer	0.047 μF 25 V
C108	Barrier Layer	0.047 μF 25 V
C109	Ceramic	300 pF 50 V
C110	Barrier Layer	0.0022 μF 25 V UAT04V 222K
C111	Ceramic	330 pF 50 V
C112	Ceramic	150 pF 50 V
C113	Ceramic	51 pF 50 V
C114	Ceramic	390 pF 50 V
C115	Barrier Layer	0.047 μF 25 V
C116	Barrier Layer	0.047 μF 25 V
C117	Ceramic	200 pF 50 V
C118	Barrier Layer	0.0018 μF 25 V UAT04V 182K
C119	Ceramic	300 pF 50 V
C120	Ceramic	270 pF 50 V
C121	Ceramic	39 pF 50 V
C122	Ceramic	300 pF 50 V
C123	Barrier Layer	0.047 μF 25 V
C124	Barrier Layer	0.047 μF 25 V
C125	Ceramic	150 pF 50 V
C126	Barrier Layer	0.0012 μF 25 V UAT04V 122K
C127	Ceramic	300 pF 50 V
C128	Ceramic	150 pF 50 V
C129	Ceramic	33 pF 50 V
C130	Ceramic	180 pF 50 V
C131	Barrier Layer	0.047 μF 25 V
C132	Ceramic	47 pF 50 V
C133	Barrier Layer	0.047 μF 25 V
C134	Ceramic	100 pF 50 V
C135	Barrier Layer	820 pF 50 V 821K RAU08SA
C136	Ceramic	270 pF 50 V
C137	Ceramic	47 pF 50 V
C138	Ceramic	47 pF 50 V
C139	Ceramic	100 pF 50 V
C140	Ceramic	30 pF 50 V
C141	Barrier Layer	0.047 μF 25 V
C142	Barrier Layer	0.1 μF 16 V
C143	Barrier Layer	0.0012 μF 25 V UAT04V 122K
C144	Barrier Layer	0.0068 μF 25 V UAT06V 682K
C145	Barrier Layer	0.001 μF 50 V RAU08SA 102K
C146	Barrier Layer	0.0027 μF 25 V UAT05V 272K
C147	Barrier Layer	0.0015 μF 25 V UAT04V 152K
C148	Barrier Layer	0.1 μF 16 V
C151	Barrier Layer	0.047 μF 25 V
C152	Barrier Layer	0.047 μF 25 V
C153	Barrier Layer	0.047 μF 25 V
C154	Ceramic	0.0047 μF 50 V
C155	Ceramic	0.0047 μF 50 V
C156	Ceramic	0.0047 μF 50 V
C157	Ceramic	0.0047 μF 50 V
C158	Ceramic	0.0047 μF 50 V
C159	Ceramic	0.0047 μF 50 V
C160	Barrier Layer	0.047 μF 25 V
C161	Barrier Layer	0.047 μF 25 V
C162	Barrier Layer	0.047 μF 25 V
C163	Ceramic	5 pF 50 V
C164	Barrier Layer	0.047 μF 25 V
C165	Barrier Layer	0.047 μF 25 V
C166	Ceramic	0.0047 μF 50 V
C167	Barrier Layer	0.1 μF 16 V
C168	Barrier Layer	0.047 μF 25 V
C169	Barrier Layer	0.047 μF 25 V
C170	Barrier Layer	0.0018 μF 25 V UAT04V 182K
C171	Barrier Layer	0.1 μF 16 V
C172	Barrier Layer	0.0022 μF 25 V UAT04V 222K
C173	Barrier Layer	0.0056 μF 25 V UAT06V 562K
C174	Barrier Layer	0.0022 μF 25 V UAT04V 222K
C175	Ceramic	30 pF 50 V
C176	Ceramic	6 pF 50 V
C177	Ceramic	39 pF 50 V
C178	Ceramic	18 pF 50 V
C179	Ceramic	22 pF 50 V
C180	Barrier Layer	0.047F 25 V
C181	Barrier Layer	0.1 μF 16 V
C182	Ceramic	0.001 μF 50 V

## [RF UNIT]

REF. NO.	DESCRIPTION	PART NO.
C183	Ceramic	0.0047 μF 50 V
C184	Ceramic	0.0047 μF 50 V
C185	Ceramic	0.0047 μF 50 V
C186	Ceramic	18 pF 50 V
C187	Ceramic	0.0047 μF 50 V
C188	Ceramic	0.0047 μF 50 V
C189	Ceramic	0.0047 μF 50 V
C190	Ceramic	0.0047 μF 50 V
C191	Ceramic	15 pF 50 V
C192	Ceramic	8 pF 50 V
C193	Electrolytic	4.7 μF 25 V RC2
C194	Barrier Layer	0.047 μF 25 V
C195	Ceramic	0.001 μF 50 V
C196	Ceramic	0.0047 μF 50 V
C197	Mylar	0.1 μF 50 V F2D
C198	Ceramic	47 pF 50 V
C199	Ceramic	82 pF 50 V
C200	Ceramic	82 pF 50 V
C203	Electrolytic	10 μF 16 V RC2
C204	Electrolytic	1 μF 50 V RC2
C205	Electrolytic	2.2 μF 50 V BP
C206	Ceramic	0.001 μF 50 V
C207	Ceramic	0.001 μF 50 V
C208	Ceramic	0.001 μF 50 V
C301	Ceramic	0.0047 μF 50 V
C302	Ceramic	0.0047 μF 50 V
C303	Ceramic	0.0047 μF 50 V
C304	Ceramic	0.0047 μF 50 V
C305	Ceramic	0.0047 μF 50 V
C306	Ceramic	0.0047 μF 50 V
C307	Ceramic	0.0047 μF 50 V
C308	Ceramic	0.0047 μF 50 V
C309	Ceramic	0.0047 μF 50 V
C310	Barrier Layer	0.1 μF 16 V
C311	Ceramic	0.001 μF 50 V
C312	Ceramic	12 pF 50 V
C313	Barrier Layer	0.1 μF 16 V
C314	Barrier Layer	0.1 μF 16 V
C315	Barrier Layer	0.1 μF 16 V
C316	Barrier Layer	0.1 μF 16 V
C317	Ceramic	2 pF 50 V
C318	Ceramic	2 pF 50 V
C319	Ceramic	15 pF 50 V
C320	Ceramic	5 pF 50 V
C321	Ceramic	8 pF 50 V
C322	Ceramic	120 pF 50 V
C323	Ceramic	0.001 μF 50 V
C324	Ceramic	0.0047 μF 50 V
C325	Ceramic	82 pF 50 V
C326	Ceramic	220 pF 50 V
C327	Ceramic	82 pF 50 V
C328	Ceramic	10 pF 50 V
C329	Ceramic	8 pF 50 V
C330	Ceramic	27 pF 50 V
C401	Ceramic	0.0047 μF 50 V
C402	Ceramic	0.0047 μF 50 V
C403	Ceramic	0.0047 μF 50 V
C404	Ceramic	0.0047 μF 50 V
C405	Ceramic	0.0047 μF 50 V
C406	Ceramic	0.0047 μF 50 V
C407	Ceramic	0.0047 μF 50 V
C408	Ceramic	0.0047 μF 50 V
C409	Ceramic	0.0047 μF 50 V
C410	Barrier Layer	0.1 μF 16 V
C411	Ceramic	0.001 μF 50 V
C412	Ceramic	12 pF 50 V
C413	Barrier Layer	0.1 μF 16 V
C414	Barrier Layer	0.1 μF 16 V
C415	Barrier Layer	0.1 μF 16 V
C416	Barrier Layer	0.1 μF 16 V
C417	Ceramic	2 pF 50 V
C418	Ceramic	2 pF 50 V
C419	Ceramic	15 pF 50 V
C420	Ceramic	5 pF 50 V
C421	Ceramic	8 pF 50 V

[RF UNIT]

REF. NO.	DESCRIPTION	PART NO.
C422	Ceramic	100 pF 50 V
C423	Ceramic	0.001 μF 50 V
C424	Ceramic	0.0047 μF 50 V
C425	Ceramic	82 pF 50 V
C426	Ceramic	220 pF 50 V
C427	Ceramic	82 pF 50 V
C428	Ceramic	10 pF 50 V
C429	Ceramic	8 pF 50 V
C430	Ceramic	27 pF 50 V
RL1	Relay	FBR21D12P
RL2	Relay	FBR21D12P
RL3	Relay	FBR21D12P
J1	Connector	TL25P-05-V1
J2	Connector	TL25P-06-V1
J3	Connector	TL25P-07-V1
J4	Connector	TMP-J01X-A2
J5	Connector	TMP-J01X-A2
J6	Connector	TMP-J01X-A2
J7	Connector	TMP-J01X-A2
J8	Connector	TMP-J01X-A2
J9	Connector	TMP-J01X-A2
J10	Connector	TL25P-03-V1
J11	Connector	TL25P-03-V1
J12	Connector	TL25P-03-V1
J13	Connector	TMP-J01X-A2
J14	Connector	TL25P-04-V1
EP1	P.C. Board	B-1334C (RF)
EP2	P.C. Board	B-1345C (MIXER A)
EP3	P.C. Board	B-1345C (MIXER B)
EP10	Ferrite Bead	DL2-OP2.6-3-1.2H
W24	Jumper	JPW-02A
W25	Jumper	JPW-02A

[PLL-A UNIT]

REF. NO.	DESCRIPTION	PART NO.
Q12	Transistor	RN1202
Q13	FET	2SK192A GR
Q14	FET	2SK192A GR
Q15	Transistor	RN1202
Q16	Transistor	RN1202
Q17	Transistor	2SC2785 EF
Q18	Transistor	2SC2026
Q19	Transistor	2SC2668 O
Q20	Transistor	2SC2668 O
Q21	Transistor	2SC2668 O
Q22	Transistor	RN2202
Q24	FET	2SK192A GR
Q25	Transistor	2SC2668 O
Q26	Transistor	2SC2668 O
Q29	Transistor	2SC2785 EF
Q30	Transistor	2SC763 C
Q31	Transistor	2SC2668 O
Q32	Transistor	2SC2668 O
Q33	Transistor	2SC2785 EF
Q34	Transistor	2SC2785 EF
Q35	Transistor	2SC2668 O
Q36	Transistor	2SC2668 O
Q37	Transistor	2SC2668 O
Q38	Transistor	2SC2785 EF
Q39	Transistor	2SC763 C
Q40	Transistor	2SC2668 O
Q41	Transistor	SC2785 EF
Q42	Transistor	2SC2785 EF
Q43	Transistor	2SC2785 EF
Q44	Transistor	2SC2785 EF
Q45	Transistor	2SC2668 O
D1	Diode	1SS53
D2	Varicap	FC52M
D3	Varicap	1SV50E (1)
D4	Diode	1SS53
D5	Diode	1SS53
D6	Diode	1SS53
D7	Diode	1SS53
D8	Diode	1SS53
D9	Diode	1SS53
D10	Diode	1SS53
D11	Diode	1SS53
D12	Varicap	1SV50E (1)
D13	Varicap	1SV50E (1)
D14	Zener	RD5.1E B2
D15	Diode	1SS53
D16	Diode	1SS53
D17	Diode	1SS53
D19	Diode	1SS53
D20	Diode	1SS53
D21	Diode	1SS53
D22	Varicap	FC52M
D24	Diode	1SS133
D25	Diode	1SS133
D26	Diode	1SS133
D27	Diode	1SS133
FI1	Monolithic	FL-91
FI2	Monolithic	FL-95
X1	Crystal	CR-228
X2	Crystal	CR-180
L1	Coil	L6 101K 100μ
L2	Coil	L6 101K 100μ
L3	Coil	LAL03NA 101K
L4	Coil	LAL03NA 101K
L5	Coil	LAL03NA 101K
L6	Coil	LAL03NA 101K
L7	Coil	LR-79

[PLL-A UNIT]

REF. NO.	DESCRIPTION	PART NO.
IC1	IC	μPD4013BC
IC2	IC	MC145158P1
IC3	IC	NJM4560DD
IC4	IC	ND487C1-3R
IC5	IC	μPC1037H
IC6	IC	μPC1037H
IC7	IC	μPC1037H
IC8	IC	SN74LS90N
IC9	IC	SN74LS90N
IC10	IC	SN74S112NS
IC11	IC	SN74S10NS
Q1	Transistor	RN1204
Q2	FET	2SK192A GR
Q3	FET	2SK192A GR
Q4	Transistor	RN1202
Q5	Transistor	RN1202
Q6	Transistor	2SC2668 O
Q7	Transistor	2SC2785 EF
Q8	Transistor	2SC2668 O
Q9	Transistor	2SC383TM
Q10	Transistor	RN1202
Q11	Transistor	RN1202

[PLL-A UNIT]

REF. NO.	DESCRIPTION	PART NO.
L8	Coil	LR-79
L9	Coil	LB-207
L10	Coil	LB-208
L11	Coil	LAL03NA 5R6K
L12	Coil	LAL03NA 4R7K
L13	Coil	LAL04NA 101K
L14	Coil	LAL03NA R68M
L15	Coil	LR-85A
L16	Coil	LA-254
L17	Coil	LA-255
L18	Coil	LA-257
L19	Coil	LA-258
L20	Coil	LAL03NA 101K
L22	Coil	LAL03NA R27M
L23	Coil	LAL03NA R47M
L24	Coil	LAL03NA R47M
L26	Coil	LAL03NA R47M
L27	Coil	LAL03NA R47M
L28	Coil	LAL03NA R56M
L29	Coil	LAL03NA R22M
L30	Coil	LAL03NA R33M
L31	Coil	LAL03NA R39M
L32	Coil	LAL03NA 101K
L33	Coil	LR-79
L34	Coil	LR-79
L35	Coil	LB-207
L36	Coil	LB-206
L37	Coil	LAL03NA 3R3K
L38	Coil	LAL03NA 2R7M
L39	Coil	LAL02NA 100K
L40	Coil	LAL03NA 470K
L41	Coil	LAL03NA 101K
L43	Coil	LAL03NA R47M
L44	Coil	LAL03NA R27M
L45	Coil	LAL03NA R27M
L46	Coil	LAL03NA R27M
L47	Coil	LAL03NA R22M
L48	Coil	LAL03NA R22M
L49	Coil	LAL03NA 101K
L50	Coil	LAL03NA R27M
L51	Coil	LAL03NA R22M
L52	Coil	LAL03NA R22M
L53	Coil	LAL03NA R27M
L54	Coil	LR-116
L55	Coil	LR-116
L56	Coil	LA-254
L57	Coil	LA-255
L58	Coil	LA-257
L59	Coil	LA-258
L60	Coil	LR-85A
L61	Coil	LAL03NA 101K
L62	Coil	LR-79
L63	Coil	LB-209
L64	Coil	LAL03NA 6R8K
L65	Coil	LAL03NA 101K
L66	Coil	LAL03NA 101K
L67	Coil	LS-247
L68	Coil	LS-247
L69	Coil	LAL04NA 101K
L70	Coil	LAL03NA 1R0M
L71	Coil	LAL03NA R82M
L72	Coil	LAL03NA 100K
L73	Coil	BT01RN1-A61
L74	Coil	LAL03NA 560K
L75	Coil	LAL03NA 560K
L76	Coil	LA-258
L77	Coil	LAL03NA R22M
L78	Coil	LAL03NA 101K
L79	Coil	LAL03NA 101K
L80	Coil	LS-198
L81	Coil	LS-198
L82	Coil	LAL03NA 151K
L83	Coil	LS-251A
L84	Coil	LAL03NA 180K
L85	Coil	LAL03NA 220K

[PLL-A UNIT]

REF. NO.	DESCRIPTION	PART NO.
L86	Coil	LS-247
L87	Coil	LS-247
L88	Coil	LS-198
L89	Coil	LS-247
L90	Coil	BT01RN1-A61
L91	Coil	LS-247
L92	Coil	LS-198
L93	Coil	LS-247
L94	Coil	LS-198
L95	Coil	LS-172
L96	Coil	LS-172
L97	Coil	LS-172
L98	Coil	LS-172
L99	Coil	LAL03NA 101K
L100	Coil	LAL03NA 101K
L101	Coil	LAL03NA R68M
L102	Coil	LAL03NA R82M
L103	Coil	LAL03NA 101K
L104	Coil	LS-164
L105	Coil	LAL03NA R68M
L106	Coil	LAL03NA 1R0M
L107	Coil	LAL03NA 221K
L108	Coil	LAL03NA R22M
R1	Resistor	10 kΩ ELR20
R2	Resistor	10 kΩ ELR20
R3	Resistor	3.3 kΩ R20
R4	Resistor	3.3 kΩ R20
R5	Resistor	8.2 kΩ ELR20
R6	Resistor	8.2 kΩ ELR20
R7	Resistor	390 Ω ELR20
R8	Resistor	390 Ω R20
R9	Resistor	100 Ω ELR20
R10	Resistor	1.8 kΩ R20
R11	Resistor	150 kΩ R20
R12	Resistor	100 kΩ ELR20
R13	Resistor	150 kΩ R20
R14	Resistor	100 kΩ ELR20
R15	Resistor	180 Ω R20
R16	Resistor	150 Ω ELR20
R17	Resistor	150 Ω ELR20
R18	Resistor	3.3 kΩ ELR20
R19	Resistor	3.3 kΩ ELR20
R20	Resistor	220 Ω ELR20
R21	Resistor	4.7 kΩ ELR20
R22	Resistor	33 Ω R20
R23	Resistor	330 Ω ELR20
R24	Resistor	47 Ω R20
R25	Resistor	220 Ω ELR20
R26	Resistor	10 kΩ ELR20
R27	Resistor	22 kΩ ELR20
R28	Resistor	100 Ω ELR20
R29	Resistor	470 Ω ELR20
R30	Resistor	10 kΩ ELR20
R31	Resistor	2.2 kΩ ELR20
R32	Resistor	100 Ω ELR20
R33	Resistor	220 Ω R20
R34	Resistor	10 Ω ELR20
R35	Resistor	1 kΩ ELR20
R36	Resistor	4.7 kΩ ELR20
R37	Resistor	1 kΩ ELR20
R38	Resistor	100 Ω R25
R39	Resistor	1 kΩ ELR20
R40	Resistor	1 kΩ ELR20
R41	Resistor	100 Ω ELR20
R42	Resistor	1 kΩ ELR20
R43	Resistor	1 kΩ R20
R44	Resistor	1 kΩ ELR20
R45	Resistor	150 kΩ R20
R46	Resistor	100 kΩ ELR20
R47	Resistor	150 kΩ ELR20
R48	Resistor	100 kΩ ELR20
R49	Resistor	150 Ω ELR20
R50	Resistor	150 Ω R20



[PLL-A UNIT]

REF. NO.	DESCRIPTION	PART NO.
R51	Resistor	3.3 kΩ R20
R52	Resistor	3.3 kΩ R20
R53	Resistor	47 kΩ ELR20
R54	Resistor	270 Ω ELR20
R55	Resistor	18 Ω ELR20
R56	Resistor	270 Ω ELR20
R57	Resistor	820 Ω ELR20
R58	Resistor	10 kΩ R20
R59	Resistor	39 Ω ELR20
R60	Resistor	4.7 kΩ ELR20
R61	Resistor	1 kΩ R20
R62	Resistor	1 kΩ ELR20
R63	Resistor	100 Ω ELR20
R64	Resistor	4.7 kΩ ELR20
R65	Resistor	22 Ω ELR20
R66	Resistor	470 kΩ ELR20
R67	Resistor	4.7 kΩ R20
R68	Resistor	470 Ω ELR20
R69	Resistor	10 kΩ ELR20
R70	Resistor	22 kΩ R20
R71	Resistor	220 Ω ELR20
R72	Resistor	100 Ω ELR20
R73	Resistor	22 Ω ELR20
R74	Resistor	270 Ω ELR20
R75	Resistor	18 Ω ELR20
R76	Resistor	270 Ω ELR20
R77	Resistor	1 kΩ R20
R78	Resistor	100 Ω R20
R79	Resistor	470 Ω R20
R80	Resistor	22 kΩ ELR20
R81	Resistor	10 kΩ ELR20
R82	Resistor	120 Ω ELR20
R83	Resistor	100 Ω ELR20
R84	Resistor	220 Ω R20
R85	Resistor	10 kΩ ELR20
R86	Resistor	4.7 kΩ ELR20
R87	Resistor	10 kΩ ELR20
R88	Resistor	4.7 kΩ R20
R89	Resistor	100 Ω R20
R90	Resistor	150 kΩ ELR20
R91	Resistor	100 kΩ R20
R92	Resistor	100 Ω R20
R93	Resistor	470 Ω ELR20
R94	Resistor	10 kΩ ELR20
R95	Resistor	2.2 kΩ ELR20
R96	Resistor	100 Ω ELR20
R97	Resistor	150 Ω ELR20
R98	Resistor	68 Ω R20
R99	Resistor	220 Ω ELR20
R100	Resistor	22 kΩ ELR20
R101	Resistor	10 kΩ ELR20
R102	Resistor	390 Ω ELR20
R103	Resistor	100 Ω ELR20
R104	Resistor	47 Ω ELR20
R110	Resistor	330 Ω ELR20
R111	Resistor	10 kΩ ELR20
R112	Resistor	1 kΩ ELR20
R113	Resistor	15 kΩ R20
R114	Resistor	47 Ω ELR20
R115	Resistor	100 Ω ELR20
R116	Resistor	4.7 kΩ ELR20
R117	Resistor	560 Ω ELR20
R118	Resistor	3.3 kΩ ELR20
R119	Resistor	100 Ω R20
R120	Resistor	47 Ω ELR20
R121	Resistor	390 Ω ELR20
R122	Resistor	10 kΩ ELR20
R123	Resistor	22 kΩ ELR20
R124	Resistor	100 Ω R20
R125	Resistor	33 Ω R20
R126	Resistor	220 Ω ELR20
R127	Resistor	22 kΩ R20
R128	Resistor	10 kΩ ELR20
R129	Resistor	1.8 kΩ R20
R130	Resistor	2.2 kΩ ELR20

[PLL-A UNIT]

REF. NO.	DESCRIPTION	PART NO.
R131	Resistor	100 Ω ELR20
R132	Resistor	270 Ω ELR20
R133	Resistor	18 Ω ELR20
R134	Resistor	270 Ω ELR20
R135	Resistor	220 Ω ELR20
R136	Resistor	10 kΩ ELR20
R137	Resistor	22 kΩ ELR20
R138	Resistor	100 Ω R20
R139	Resistor	680 Ω ELR20
R140	Resistor	1.2 kΩ R20
R142	Resistor	100 Ω R20
R143	Resistor	3.3 kΩ ELR20
R144	Resistor	18 Ω R20
R145	Resistor	56 Ω ELR20
R146	Resistor	150 Ω ELR20
R147	Resistor	22 kΩ ELR20
R148	Resistor	10 kΩ ELR20
R149	Resistor	100 Ω R20
R150	Resistor	470 Ω ELR20
R151	Resistor	68 Ω R20
R152	Resistor	68 Ω R20
R153	Resistor	390 Ω ELR20
R154	Resistor	100 Ω R20
R155	Resistor	22 kΩ R20
R156	Resistor	10 kΩ ELR20
R157	Resistor	56 Ω ELR20
R158	Resistor	150 Ω ELR20
R159	Resistor	3.3 kΩ ELR20
R160	Resistor	100 Ω R20
R161	Resistor	220 Ω R20
R162	Resistor	470 Ω ELR20
R163	Resistor	22 kΩ ELR20
R164	Resistor	10 kΩ ELR20
R165	Resistor	470 Ω ELR20
R166	Resistor	10 kΩ ELR20
R167	Resistor	1 kΩ ELR20
R168	Resistor	15 kΩ ELR20
R169	Resistor	100 Ω R20
R170	Resistor	220 Ω ELR20
R171	Resistor	10 kΩ ELR20
R172	Resistor	4.7 Ω ELR20
R173	Resistor	1 kΩ ELR20
R174	Resistor	6.8 kΩ ELR20
R175	Resistor	4.7 kΩ ELR20
R176	Resistor	10 kΩ ELR20
R177	Resistor	2.2 kΩ ELR20
R178	Resistor	100 Ω ELR20
R179	Resistor	220 Ω ELR20
R180	Resistor	470 Ω ELR20
R181	Resistor	220 Ω ELR20
R182	Resistor	10 kΩ ELR20
R183	Resistor	22 kΩ ELR20
R184	Resistor	100 Ω ELR20
R185	Resistor	3.3 kΩ ELR20
R187	Resistor	56 Ω R20
R188	Resistor	1 kΩ ELR20
R189	Resistor	470 Ω ELR20
R190	Resistor	10 kΩ ELR20
R191	Resistor	10 kΩ ELR20
R192	Resistor	1 kΩ ELR20
R193	Resistor	1.2 kΩ R20
R194	Resistor	100 Ω R20
R195	Resistor	100 Ω ELR20
R196	Resistor	1 kΩ MCR10
R198	Resistor	47 kΩ ELR20
R199	Resistor	470 Ω R20
R204	Resistor	47 kΩ ELR20
R205	Resistor	47 kΩ ELR20
R206	Chip Jumper	MCR10-JPW
C1	Electrolytic	10 μF 16 V MS7
C2	Electrolytic	10 μF 16 V MS7
C3	Barrier Layer	0.1 μF 16 V
C4	Electrolytic	47 μF 16 V SS

[PLL-A UNIT]

REF. NO.	DESCRIPTION	PART NO.	
C5	Barrier Layer	0.1 μF	16 V
C6	Barrier Layer	0.01 μF	25 V
C7	Barrier Layer	0.047 μF	25 V
C8	Electrolytic	10 μF	16 V MS7
C9	Ceramic	120 pF	50 V
C10	Ceramic	0.001 μF	50 V
C11	Ceramic	0.001 μF	50 V
C12	Barrier Layer	0.1 μF	16 V
C13	Barrier Layer	0.047 μF	25 V
C14	Electrolytic	100 μF	16 V SS
C15	Electrolytic	1 μF	50 V BP
C17	Tantalum	1 μF	35 V DN
C18	Barrier Layer	0.047 μF	25 V
C19	Ceramic	100 pF	50 V PH
C20	Ceramic	100 pF	50 V PH
C21	Ceramic	22 pF	50 V CH
C22	Ceramic	3 pF	50 V CJ
C23	Trimmer	6 pF	CV05A0601
C24	Trimmer	6 pF	CV05A0601
C25	Ceramic	68 pF	50 V CH
C26	Ceramic	33 pF	50 V CH
C27	Ceramic	22 pF	50 V CH
C28	Ceramic	12 pF	50 V CH
C29	Ceramic	10 pF	50 V CH
C30	Ceramic	10 pF	50 V CH
C31	Ceramic	0.0047 μF	50 V
C32	Ceramic	0.0047 μF	50 V
C33	Electrolytic	100 μF	16 V SS
C34	Ceramic	0.0047 μF	50 V
C35	Ceramic	0.0047 μF	50 V
C36	Ceramic	0.0047 μF	50 V
C37	Ceramic	1 pF	50 V CK
C38	Ceramic	1 pF	50 V CK
C39	Ceramic	0.001 μF	50 V
C40	Ceramic	0.001 μF	50 V
C41	Ceramic	0.0047 μF	50 V
C42	Ceramic	0.001 μF	50 V
C43	Ceramic	0.0047 μF	50 V
C44	Ceramic	0.0047 μF	50 V
C45	Ceramic	8 pF	50 V
C46	Ceramic	33 pF	50 V
C47	Ceramic	33 pF	50 V
C48	Ceramic	51 pF	50 V
C49	Ceramic	56 pF	50 V
C50	Ceramic	180 pF	50 V
C51	Ceramic	120 pF	50 V
C52	Ceramic	0.0047 μF	50 V
C53	Ceramic	0.0047 μF	50 V
C54	Ceramic	0.0047 μF	50 V
C55	Ceramic	0.001 μF	50 V
C57	Ceramic	0.0047 μF	50 V
C58	Ceramic	100 pF	50 V
C59	Ceramic	100 pF	50 V
C60	Ceramic	220 pF	50 V
C61	Ceramic	27 pF	50 V
C62	Ceramic	270 pF	50 V
C63	Ceramic	15 pF	50 V
C64	Ceramic	120 pF	50 V
C65	Barrier Layer	0.0047 μF	25 V
C67	Ceramic	270 pF	50 V
C68	Ceramic	0.001 μF	50 V
C69	Ceramic	150 pF	50 V
C70	Ceramic	220 pF	50 V
C71	Ceramic	470 pF	50 V
C72	Ceramic	180 pF	50 V
C73	Ceramic	0.001 μF	50 V
C74	Ceramic	75 pF	50 V
C75	Ceramic	75 pF	50 V
C76	Ceramic	150 pF	50 V
C77	Ceramic	36 pF	50 V
C78	Ceramic	200 pF	50 V
C79	Ceramic	10 pF	50 V
C80	Ceramic	120 pF	50 V
C81	Ceramic	0.0047 μF	50 V
C82	Ceramic	0.0047 μF	50 V

[PLL-A UNIT]

REF. NO.	DESCRIPTION	PART NO.	
C83	Ceramic	0.001 μF	50 V
C84	Ceramic	0.001 μF	50 V
C85	Ceramic	0.001 μF	50 V
C86	Ceramic	0.001 μF	50 V
C87	Barrier Layer	0.047 μF	25 V
C88	Ceramic	82 pF	50 V PH
C89	Ceramic	82 pF	50 V PH
C90	Ceramic	5 pF	50 V CH
C91	Ceramic	8 pF	50 V CH
C92	Trimmer	6 pF	CV05A0601
C93	Trimmer	6 pF	CV05A0601
C94	Ceramic	47 pF	50 V CH
C95	Ceramic	47 pF	50 V CH
C96	Ceramic	18 pF	50 V CH
C97	Ceramic	18 pF	50 V CH
C98	Ceramic	10 pF	50 V CH
C99	Ceramic	8 pF	50 V CH
C100	Ceramic	0.0047 μF	50 V
C101	Ceramic	0.0047 μF	50 V
C102	Ceramic	0.0047 μF	50 V
C103	Ceramic	0.0047 μF	50 V
C104	Ceramic	1 pF	50 V CK
C105	Ceramic	1 pF	50 V CK
C106	Ceramic	0.001 μF	50 V
C107	Ceramic	0.001 μF	50 V
C108	Ceramic	0.001 μF	50 V
C109	Ceramic	0.0047 μF	50 V
C110	Electrolytic	10 μF	16 V MS7
C111	Ceramic	0.01 μF	50 V
C112	Barrier Layer	0.1 μF	16 V
C113	Ceramic	0.0047 μF	50 V
C115	Ceramic	200 pF	50 V
C116	Ceramic	200 pF	50 V
C117	Ceramic	100 pF	50 V
C118	Ceramic	220 pF	50 V
C119	Ceramic	470 pF	50 V
C120	Ceramic	82 pF	50 V
C121	Ceramic	0.0012 μF	25 V
C122	Ceramic	150 pF	50 V
C123	Ceramic	75 pF	50 V
C124	Ceramic	18 pF	50 V
C125	Ceramic	120 pF	50 V
C126	Ceramic	47 pF	50 V
C127	Ceramic	100 pF	50 V
C128	Ceramic	0.0047 μF	50 V
C129	Ceramic	0.0047 μF	50 V
C130	Ceramic	0.0047 μF	50 V
C131	Ceramic	0.01 μF	50 V
C132	Barrier Layer	0.047 μF	25 V
C133	Barrier Layer	0.0047 μF	25 V
C134	Ceramic	0.001 μF	50 V
C135	Ceramic	0.001 μF	50 V
C136	Ceramic	75 pF	50 V
C137	Ceramic	18 pF	50 V
C138	Ceramic	120 pF	50 V
C139	Ceramic	47 pF	50 V
C140	Ceramic	100 pF	50 V
C141	Ceramic	100 pF	50 V
C142	Ceramic	100 pF	50 V
C143	Ceramic	3 pF	50 V
C144	Ceramic	33 pF	50 V
C145	Ceramic	33 pF	50 V
C146	Ceramic	51 pF	50 V
C147	Ceramic	62 pF	50 V
C148	Ceramic	180 pF	50 V
C149	Ceramic	120 pF	50 V
C150	Ceramic	0.0047 μF	50 V
C151	Barrier Layer	0.0047 μF	25 V
C152	Ceramic	0.0047 μF	50 V
C153	Ceramic	0.001 μF	50 V
C154	Ceramic	0.001 μF	50 V
C155	Barrier Layer	0.047 μF	25 V
C157	Ceramic	0.01 μF	50 V
C158	Tantalum	0.1 μF	35 V DN
C159	Ceramic	10 pF	50 V PH

[PLL-A UNIT]

REF. NO.	DESCRIPTION	PART NO.	
C160	Trimmer	6 pF	CV05A0601
C161	Ceramic	10 pF	50 V CH
C162	Ceramic	56 pF	50 V CH
C163	Ceramic	27 pF	50 V CH
C164	Ceramic	8 pF	50 V CH
C165	Electrolytic	10 μF	16 V MS7
C166	Ceramic	0.0047 μF	50 V
C167	Ceramic	1 pF	50 V CK
C168	Ceramic	0.0047 μF	50 V
C169	Ceramic	0.001 μF	50 V
C170	Ceramic	0.0047 μF	50 V
C171	Ceramic	0.0047 μF	50 V
C172	Ceramic	0.001 μF	50 V
C173	Ceramic	10 pF	50 V
C174	Ceramic	0.5 pF	50 V
C175	Ceramic	10 pF	50 V
C176	Barrier Layer	0.01 μF	25 V
C179	Ceramic	0.001 μF	50 V
C180	Ceramic	270 pF	50 V
C181	Ceramic	62 pF	50 V
C182	Ceramic	270 pF	50 V
C183	Ceramic	0.0047 μF	50 V
C184	Barrier Layer	0.1 μF	16 V
C185	Electrolytic	47 μF	25 V SS
C186	Barrier Layer	0.1 μF	16 V
C187	Electrolytic	10 μF	16 V MS7
C188	Barrier Layer	0.1 μF	16 V
C189	Barrier Layer	0.1 μF	16 V
C190	Ceramic	100 pF	50 V
C191	Ceramic	220 pF	50 V
C192	Ceramic	100 pF	50 V
C193	Barrier Layer	0.1 μF	16 V
C194	Barrier Layer	0.1 μF	16 V
C195	Barrier Layer	0.0047 μF	25 V
C196	Electrolytic	10 μF	16 V MS7
C197	Barrier Layer	0.1 μF	16 V
C198	Ceramic	0.0047 μF	50 V
C199	Cylinder	0.0047 μF	EP050X 472N-NA
C200	Ceramic	0.0047 μF	50 V
C201	Ceramic	68 pF	50 V
C202	Ceramic	18 pF	50 V
C203	Ceramic	6 pF	50 V
C204	Ceramic	120 pF	50 V
C205	Ceramic	6 pF	50 V
C206	Ceramic	10 pF	50 V
C207	Ceramic	68 pF	50 V
C208	Barrier Layer	0.0047 μF	25 V
C209	Barrier Layer	0.0047 μF	25 V
C210	Ceramic	0.001 μF	50 V
C211	Barrier Layer	0.0047 μF	25 V
C212	Barrier Layer	0.0047 μF	25 V
C213	Barrier Layer	0.01 μF	25 V
C214	Ceramic	18 pF	50 V
C215	Barrier Layer	0.0047 μF	25 V
C216	Ceramic	0.5 pF	50 V
C217	Ceramic	18 pF	50 V
C218	Barrier Layer	0.1 μF	16 V
C219	Barrier Layer	0.01 μF	25 V
C220	Barrier Layer	0.1 μF	16 V
C221	Ceramic	470 pF	50 V
C222	Barrier Layer	0.1 μF	16 V
C223	Ceramic	0.01 μF	50 V
C224	Ceramic	0.001 μF	50 V
C225	Ceramic	0.01 μF	50 V
C226	Ceramic	0.001 μF	50 V
C227	Barrier Layer	0.0056 μF	25 V
C228	Ceramic	0.001 μF	50 V
C229	Barrier Layer	0.1 μF	16 V
C230	Ceramic	0.0047 μF	50 V
C231	Barrier Layer	0.1 μF	16 V
C232	Ceramic	0.0047 μF	50 V
C233	Electrolytic	10 μF	16 V MS7
C234	Barrier Layer	0.1 μF	16 V
C235	Ceramic	0.0047 μF	50 V
C236	Ceramic	0.0047 μF	50 V

[PLL-A UNIT]

REF. NO.	DESCRIPTION	PART NO.	
C237	Ceramic	12 pF	50 V
C238	Ceramic	12 pF	50 V
C239	Barrier Layer	0.1 μF	16 V
C240	Ceramic	0.0047 μF	50 V
C241	Ceramic	0.0047 μF	50 V
C242	Ceramic	12 pF	50 V
C243	Barrier Layer	0.0047 μF	25 V
C244	Ceramic	12 pF	50 V
C245	Electrolytic	47 μF	25 V SS
C246	Ceramic	0.0047 μF	50 V
C247	Ceramic	12 pF	50 V
C248	Ceramic	12 pF	50 V
C249	Ceramic	0.0047 μF	50 V
C250	Ceramic	0.0047 μF	50 V
C251	Ceramic	0.0047 μF	50 V
C252	Ceramic	12 pF	50 V
C253	Ceramic	12 pF	50 V
C254	Ceramic	0.001 μF	50 V
C255	Ceramic	0.0047 μF	50 V
C256	Cylinder	0.001 μF	UP125D 102M-NA
C257	Ceramic	0.0047 μF	50 V
C258	Ceramic	0.0047 μF	50 V
C259	Ceramic	1 pF	50 V
C260	Ceramic	7 pF	50 V
C261	Ceramic	7 pF	50 V
C262	Ceramic	0.0047 μF	50 V
C263	Ceramic	0.0047 μF	50 V
C264	Ceramic	10 pF	50 V
C265	Ceramic	7 pF	50 V
C266	Ceramic	0.5 pF	50 V
C267	Ceramic	7 pF	50 V
C268	Ceramic	0.0047 μF	50 V
C269	Ceramic	47 pF	50 V
C270	Electrolytic	10 μF	16 V MS7
C271	Barrier Layer	0.047 μF	25 V
C272	Barrier Layer	0.0047 μF	25 V
C273	Ceramic	0.001 μF	50 V
C274	Ceramic	0.001 μF	50 V
C275	Ceramic	0.001 μF	50 V
C276	Ceramic	0.0047 μF	50 V
C277	Ceramic	0.0047 μF	50 V
C278	Ceramic	0.01 μF	50 V
C279	Barrier Layer	0.0047 μF	25 V
C280	Barrier Layer	0.01 μF	25 V
C281	Ceramic	220 pF	50 V
C282	Ceramic	47 pF	50 V
C283	Ceramic	470 pF	50 V
C284	Ceramic	18 pF	50 V
C285	Ceramic	270 pF	50 V
C286	Ceramic	0.0047 μF	50 V
C287	Ceramic	0.0047 μF	50 V
C288	Ceramic	0.001 μF	50 V
C289	Ceramic	0.0047 μF	50 V
C290	Ceramic	120 pF	50 V
C291	Ceramic	0.0047 μF	50 V
C292	Ceramic	470 pF	50 V
C293	Ceramic	82 pF	50 V
C294	Ceramic	56 pF	50 V
C295	Ceramic	330 pF	50 V
C296	Barrier Layer	0.1 μF	16 V
C297	Barrier Layer	0.1 μF	16 V
C298	Barrier Layer	0.1 μF	16 V
C299	Ceramic	0.0047 μF	50 V
C300	Ceramic	0.001 μF	GRM40
C301	Ceramic	0.01 μF	GRM40 F
C302	Ceramic	0.1 μF	GRM40 F
C303	Barrier Layer	0.047 μF	25 V
C304	Ceramic	56 pF	50 V
C305	Barrier Layer	0.1 μF	16 V
J1	Connector	TLB-P04H-B1	
J2	Connector	TLB-P03H-B1	
J3	Connector	TLB-P06H-B1	
J5	Connector	TMP-J01X-V6	

[PLL-A UNIT]

REF. NO.	DESCRIPTION	PART NO.
J6	Connector	TMP-J01X-V6
J9	Connector	TMP-J01X-V6
P1	Connector	TL25H-04-B1
P2	Connector	TL25H-03-B1
P3	Connector	TL25H-05-B1
P4	Connector	TL25H-07-B1
P5	Connector	TMP-P01X-A1
P6	Connector	TMP-P01X-A1
P7	Connector	TMP-P01X-A1
P8	Connector	TMP-P01X-A1
P9	Connector	TMP-P01X-A1
P10	Connector	TMP-P01X-A1
EP1	P.C. Board	B-1335A (PLL-A)
EP2	P.C. Board	B-1515B (EP2)
W11	Jumper	JPW-01 R01

[PLL-B UNIT]

REF. NO.	DESCRIPTION	PART NO.
IC2	IC	MC145158P1
IC3	IC	NJM4560DD
IC4	IC	ND487C1-3R
IC5	IC	μPC1037H
IC8	IC	SN74LS90N
IC10	IC	SN74S112NS
IC11	IC	SN74S10NS
Q2	FET	2SK192A GR
Q3	FET	2SK192A GR
Q4	Transistor	RN1202
Q5	Transistor	RN1202
Q6	Transistor	2SC2668 O
Q7	Transistor	2SC2785 EF
Q8	Transistor	2SC2668 O
Q9	Transistor	2SC383TM
Q10	Transistor	RN1202
Q11	Transistor	RN1202
Q12	Transistor	RN1202
Q13	FET	2SK192A GR
Q14	FET	2SK192A GR
Q15	Transistor	RN1202
Q16	Transistor	RN1202
Q17	Transistor	2SC2785 EF
Q18	Transistor	2SC2026
Q19	Transistor	2SC2668 O
Q20	Transistor	2SC2668 O
Q21	Transistor	2SC2668 O
Q22	Transistor	RN2202
Q24	FET	2SK192A GR
Q25	Transistor	2SC2668 O
Q26	Transistor	2SC2668 O
Q27	Transistor	2SC2668 O
Q28	Transistor	2SC763 C
Q30	Transistor	2SC763 C
Q31	Transistor	2SC2668 O
Q32	Transistor	2SC2668 O
Q39	Transistor	2SC763 C
Q40	Transistor	2SC2668 O
Q42	Transistor	2SC2785 EF
Q43	Transistor	2SC2785 EF
Q45	Transistor	2SC2668 O
Q46	Transistor	RN1204
Q47	Transistor	2SC2785 EF
D1	Diode	1SS53
D2	Varicap	FC52M
D3	Varicap	1SV50E (1)
D4	Diode	1SS53
D5	Diode	1SS53
D6	Diode	1SS53
D7	Diode	1SS53
D8	Diode	1SS53
D9	Diode	1SS53
D10	Diode	1SS53
D11	Diode	1SS53
D12	Varicap	1SV50E (1)
D13	Varicap	1SV50E (1)
D14	Zener	RD5.1E B2
D15	Diode	1SS53
D16	Diode	1SS53
D17	Diode	1SS53
D18	Diode	1SS53
D19	Diode	1SS53
D20	Diode	1SS53
D21	Diode	1SS53
D22	Varicap	FC52M
D24	Diode	1SS133
D25	Diode	1SS133
D26	Diode	1SS133
D27	Diode	1SS133

[DDS-A UNIT]

REF. NO.	DESCRIPTION	PART NO.
IC1	IC	SC-1051
IC2	IC	SC-1052
IC3	IC	SC-1053
IC4	IC	TC74HCT374F
IC5	IC	TC74HCT374F
L1	Coil	LQN5N331K 330μ
L2	Coil	LQN5N331K 330μ
L3	Coil	LQN5N331K 330μ
R1	Resistor	1 MΩ MCR10
R2	Resistor	680 MΩ MCR10
R3	Resistor	2.2 kΩ MCR10
R4	Array	GF5096
C1	Trimmer	10 pF TZB04N100BA
C2	Ceramic	33 pF GRM40 CH
C3	Ceramic	0.1 μF GRM40 F
C7	Ceramic	68 pF GRM40
C8	Ceramic	2 pF GRM40
C9	Ceramic	120 pF GRM40
C10	Ceramic	7 pF GRM40
C11	Ceramic	120 pF GRM40
C12	Ceramic	12 pF GRM40
C13	Ceramic	68 pF GRM40
C14	Ceramic	0.1 μF GRM40 F
C15	Ceramic	0.1 μF GRM40 F
C16	Ceramic	0.1 μF GRM40 F
C17	Ceramic	0.1 μF GRM40 F
C18	Ceramic	10 pF GRM40 UJ
C19	Ceramic	0.001 μF GRM40
C20	Ceramic	220 pF GRM40
J1	Connector	3022-03A
J2	Connector	3022-06A
EP1	P.C. Board	B-1233C



[PLL-B UNIT]

REF. NO.	DESCRIPTION	PART NO.
L1	Coil	L6 101K 100μ
L2	Coil	L6 101K 100μ
L3	Coil	LAL03NA 101K
L5	Coil	LAL03NA 101K
L6	Coil	LAL03NA 101K
L7	Coil	LR-79
L8	Coil	LR-79
L9	Coil	LB-207
L10	Coil	LB-208
L11	Coil	LAL03NA 5R6K
L12	Coil	LAL03NA 4R7K
L13	Coil	LAL04NA 101K
L14	Coil	LAL03NA R68M
L15	Coil	LR-85A
L16	Coil	LA-254
L17	Coil	LA-255
L18	Coil	LA-257
L19	Coil	LA-258
L20	Coil	LAL03NA 101K
L22	Coil	LAL03NA R27M
L23	Coil	LAL03NA R47M
L24	Coil	LAL03NA R47M
L26	Coil	LAL03NA R47M
L27	Coil	LAL03NA R47M
L28	Coil	LAL03NA R56M
L29	Coil	LAL03NA R22M
L30	Coil	LAL03NA R33M
L31	Coil	LAL03NA R39M
L32	Coil	LAL03NA 101K
L33	Coil	LR-79
L34	Coil	LR-79
L35	Coil	LB-207
L36	Coil	LB-206
L37	Coil	LAL03NA 3R3K
L38	Coil	LAL03NA 2R7M
L39	Coil	LAL02NA 100K
L40	Coil	LAL03NA 470K
L41	Coil	LAL03NA 101K
L43	Coil	LAL03NA R47M
L44	Coil	LAL03NA R27M
L45	Coil	LAL03NA R27M
L46	Coil	LAL03NA R27M
L47	Coil	LAL03NA R22M
L48	Coil	LAL03NA R22M
L49	Coil	LAL03NA 101K
L50	Coil	LAL03NA R27M
L51	Coil	LAL03NA R22M
L52	Coil	LAL03NA R22M
L53	Coil	LAL03NA R27M
L54	Coil	LR-116
L55	Coil	LR-116
L56	Coil	LA-254
L57	Coil	LA-255
L58	Coil	LA-257
L59	Coil	LA-258
L60	Coil	LR-85A
L61	Coil	LAL03NA 101K
L62	Coil	LR-79
L63	Coil	LB-209
L64	Coil	LAL03NA 6R8K
L65	Coil	LAL03NA 101K
L66	Coil	LAL03NA 101K
L67	Coil	LS-247
L68	Coil	LS-247
L69	Coil	LAL04NA 101K
L72	Coil	LAL03NA 100K
L74	Coil	LAL03NA 560K
L75	Coil	LAL03NA 560K
L76	Coil	LA-258
L77	Coil	LAL03NA R22M
L78	Coil	LAL03NA 101K
L99	Coil	LAL03NA 101K
L103	Coil	LAL03NA 101K
L104	Coil	LS-247
L108	Coil	LAL03NA R22M

[PLL-B UNIT]

REF. NO.	DESCRIPTION	PART NO.
R2	Resistor	10 kΩ ELR20
R3	Resistor	3.3 kΩ R20
R4	Resistor	3.3 kΩ R20
R5	Resistor	8.2 kΩ ELR20
R6	Resistor	8.2 kΩ ELR20
R7	Resistor	390 Ω ELR20
R8	Resistor	390 Ω R20
R9	Resistor	100 Ω ELR20
R10	Resistor	1.8 kΩ R20
R11	Resistor	150 kΩ R20
R12	Resistor	100 kΩ ELR20
R13	Resistor	150 kΩ R20
R14	Resistor	100 kΩ ELR20
R15	Resistor	180 Ω R20
R16	Resistor	150 Ω ELR20
R17	Resistor	150 Ω ELR20
R18	Resistor	3.3 kΩ ELR20
R19	Resistor	3.3 kΩ ELR20
R20	Resistor	220 Ω ELR20
R21	Resistor	4.7 kΩ ELR20
R22	Resistor	33 Ω R20
R23	Resistor	330 Ω ELR20
R24	Resistor	47 Ω R20
R25	Resistor	220 Ω ELR20
R26	Resistor	10 kΩ ELR20
R27	Resistor	22 kΩ ELR20
R28	Resistor	100 Ω ELR20
R29	Resistor	470 Ω ELR20
R30	Resistor	10 kΩ ELR20
R31	Resistor	2.2 kΩ ELR20
R32	Resistor	100 Ω ELR20
R33	Resistor	220 Ω R20
R34	Resistor	10 Ω ELR20
R35	Resistor	1 kΩ ELR20
R36	Resistor	4.7 kΩ ELR20
R37	Resistor	1 kΩ ELR20
R38	Resistor	100 Ω R25
R39	Resistor	1 kΩ ELR20
R40	Resistor	1 kΩ ELR20
R41	Resistor	100 Ω ELR20
R42	Resistor	1 kΩ ELR20
R43	Resistor	1 kΩ R20
R44	Resistor	1 kΩ ELR20
R45	Resistor	150 kΩ R20
R46	Resistor	100 kΩ ELR20
R47	Resistor	150 kΩ ELR20
R48	Resistor	100 kΩ ELR20
R49	Resistor	150 Ω ELR20
R50	Resistor	150 Ω R20
R51	Resistor	3.3 kΩ R20
R52	Resistor	3.3 kΩ R20
R53	Resistor	47 kΩ ELR20
R54	Resistor	270 Ω ELR20
R55	Resistor	18 Ω ELR20
R56	Resistor	270 Ω ELR20
R57	Resistor	820 Ω ELR20
R58	Resistor	10 kΩ R20
R59	Resistor	39 Ω ELR20
R60	Resistor	4.7 kΩ ELR20
R61	Resistor	1 kΩ R20
R62	Resistor	1 kΩ ELR20
R63	Resistor	100 Ω ELR20
R64	Resistor	4.7 kΩ ELR20
R65	Resistor	22 Ω ELR20
R66	Resistor	470 Ω ELR20
R67	Resistor	4.7 kΩ R20
R68	Resistor	470 Ω ELR20
R69	Resistor	10 kΩ ELR20
R70	Resistor	22 kΩ R20
R71	Resistor	220 Ω ELR20
R72	Resistor	100 Ω ELR20
R73	Resistor	22 Ω ELR20
R74	Resistor	270 Ω ELR20
R75	Resistor	18 Ω ELR20
R76	Resistor	270 Ω ELR20

[PLL-B UNIT]

REF. NO.	DESCRIPTION	PART NO.	
R77	Resistor	1 kΩ	R20
R78	Resistor	100 Ω	R20
R79	Resistor	470 Ω	R20
R80	Resistor	22 kΩ	ELR20
R81	Resistor	10 kΩ	ELR20
R82	Resistor	120 Ω	ELR20
R83	Resistor	100 Ω	ELR20
R84	Resistor	220 Ω	R20
R85	Resistor	10 kΩ	ELR20
R86	Resistor	4.7 kΩ	ELR20
R87	Resistor	10 kΩ	ELR20
R88	Resistor	4.7 kΩ	R20
R89	Resistor	100 Ω	R20
R90	Resistor	150 kΩ	ELR20
R91	Resistor	100 kΩ	R20
R92	Resistor	100 Ω	R20
R93	Resistor	470 Ω	ELR20
R94	Resistor	10 kΩ	ELR20
R95	Resistor	2.2 kΩ	ELR20
R96	Resistor	100 Ω	ELR20
R97	Resistor	150 Ω	ELR20
R98	Resistor	68 Ω	R20
R99	Resistor	220 Ω	ELR20
R100	Resistor	22 kΩ	ELR20
R101	Resistor	10 kΩ	ELR20
R102	Resistor	390 Ω	ELR20
R103	Resistor	100 Ω	ELR20
R104	Resistor	47 Ω	ELR20
R105	Resistor	5.6 kΩ	ELR20
R106	Resistor	1.2 kΩ	ELR20
R107	Resistor	220 Ω	ELR20
R108	Resistor	15 kΩ	ELR20
R109	Resistor	1 kΩ	ELR20
R112	Resistor	1 kΩ	ELR20
R113	Resistor	15 kΩ	R20
R114	Resistor	47 Ω	ELR20
R115	Resistor	100 Ω	ELR20
R116	Resistor	4.7 kΩ	ELR20
R117	Resistor	560 Ω	ELR20
R118	Resistor	3.3 kΩ	ELR20
R119	Resistor	100 Ω	R20
R120	Resistor	47 Ω	ELR20
R121	Resistor	390 Ω	ELR20
R122	Resistor	10 kΩ	ELR20
R123	Resistor	22 kΩ	ELR20
R124	Resistor	100 Ω	R20
R125	Resistor	33 Ω	R20
R126	Resistor	220 Ω	ELR20
R167	Resistor	1 kΩ	ELR20
R168	Resistor	15 kΩ	ELR20
R169	Resistor	100 Ω	R20
R170	Resistor	220 Ω	ELR20
R171	Resistor	10 kΩ	ELR20
R172	Resistor	4.7 kΩ	ELR20
R173	Resistor	1 kΩ	ELR20
R181	Resistor	220 Ω	ELR20
R182	Resistor	10 kΩ	ELR20
R183	Resistor	22 kΩ	ELR20
R184	Resistor	100 Ω	ELR20
R188	Resistor	1 kΩ	ELR20
R189	Resistor	470 Ω	ELR20
R190	Resistor	10 kΩ	ELR20
R194	Resistor	100 Ω	R20
R195	Resistor	100 Ω	ELR20
R196	Resistor	1 kΩ	MCR10
R197	Resistor	10 kΩ	ELR20
R198	Resistor	47 kΩ	ELR20
R199	Resistor	470 Ω	R20
R206	Chip Jumper	MCR10-JPW	
C1	Electrolytic	10 μF	16 V MS7
C2	Electrolytic	10 μF	16 V MS7
C3	Barrier Layer	0.1 μF	16 V
C6	Barrier Layer	0.01 μF	25 V

[PLL-B UNIT]

REF. NO.	DESCRIPTION	PART NO.	
C7	Barrier Layer	0.047 μF	25 V
C8	Electrolytic	10 μF	16 V MS7
C9	Ceramic	120 pF	50 V
C10	Ceramic	0.001 μF	50 V
C11	Ceramic	0.001 μF	50 V
C12	Barrier Layer	0.1 μF	16 V
C13	Barrier Layer	0.047 μF	25 V
C14	Electrolytic	100 μF	16 V SS
C15	Electrolytic	1 μF	50 V BP
C17	Tantalum	1 μF	35 V DN
C18	Barrier Layer	0.047 μF	25 V
C19	Ceramic	100 pF	50 V PH
C20	Ceramic	100 pF	50 V PH
C21	Ceramic	22 pF	50 V CH
C22	Ceramic	3 pF	50 V CJ
C23	Trimmer	6 pF	CV05A0601
C24	Trimmer	6 pF	CV05A0601
C25	Ceramic	68 pF	50 V CH
C26	Ceramic	33 pF	50 V CH
C27	Ceramic	22 pF	50 V CH
C28	Ceramic	12 pF	50 V CH
C29	Ceramic	10 pF	50 V CH
C30	Ceramic	10 pF	50 V CH
C31	Ceramic	0.0047 μF	50 V
C32	Ceramic	0.0047 μF	50 V
C33	Electrolytic	100 μF	16 V SS
C34	Ceramic	0.0047 μF	50 V
C35	Ceramic	0.0047 μF	50 V
C36	Ceramic	0.0047 μF	50 V
C37	Ceramic	1 pF	50 V CK
C38	Ceramic	1 pF	50 V CK
C39	Ceramic	0.001 μF	50 V
C40	Ceramic	0.001 μF	50 V
C41	Ceramic	0.0047 μF	50 V
C42	Ceramic	0.001 μF	50 V
C43	Ceramic	0.0047 μF	50 V
C44	Ceramic	0.0047 μF	50 V
C45	Ceramic	8 pF	50 V
C46	Ceramic	33 pF	50 V
C47	Ceramic	33 pF	50 V
C48	Ceramic	51 pF	50 V
C49	Ceramic	56 pF	50 V
C50	Ceramic	180 pF	50 V
C51	Ceramic	120 pF	50 V
C52	Ceramic	0.0047 μF	50 V
C53	Ceramic	0.0047 μF	50 V
C54	Ceramic	0.0047 μF	50 V
C55	Ceramic	0.001 μF	50 V
C57	Ceramic	0.0047 μF	50 V
C58	Ceramic	100 pF	50 V
C59	Ceramic	100 pF	50 V
C60	Ceramic	220 pF	50 V
C61	Ceramic	27 pF	50 V
C62	Ceramic	270 pF	50 V
C63	Ceramic	15 pF	50 V
C64	Ceramic	120 pF	50 V
C65	Ceramic	0.0047 μF	25 V
C67	Ceramic	270 pF	50 V
C68	Ceramic	0.001 μF	50 V
C69	Ceramic	150 pF	50 V
C70	Ceramic	220 pF	50 V
C71	Ceramic	470 pF	50 V
C72	Ceramic	180 pF	50 V
C73	Ceramic	0.001 μF	50 V
C74	Ceramic	75 pF	50 V
C75	Ceramic	75 pF	50 V
C76	Ceramic	150 pF	50 V
C77	Ceramic	36 pF	50 V
C78	Ceramic	200 pF	50 V
C79	Ceramic	10 pF	50 V
C80	Ceramic	120 pF	50 V
C81	Ceramic	0.0047 μF	50 V
C82	Ceramic	0.0047 μF	50 V
C83	Ceramic	0.001 μF	50 V
C84	Ceramic	0.001 μF	50 V

[PLL-B UNIT]

REF. NO.	DESCRIPTION	PART NO.
C85	Ceramic	0.001 μF 50 V
C86	Ceramic	0.001 μF 50 V
C87	Barrier Layer	0.047 μF 25 V
C88	Ceramic	82 pF 50 V PH
C89	Ceramic	82 pF 50 V PH
C90	Ceramic	5 pF 50 V CH
C91	Ceramic	8 pF 50 V CH
C92	Trimmer	6 pF CV05A0601
C93	Trimmer	6 pF CV05A0601
C94	Ceramic	47 pF 50 V CH
C95	Ceramic	47 pF 50 V CH
C96	Ceramic	18 pF 50 V CH
C97	Ceramic	18 pF 50 V CH
C98	Ceramic	10 pF 50 V CH
C99	Ceramic	8 pF 50 V CH
C100	Ceramic	0.0047 μF 50 V
C101	Ceramic	0.0047 μF 50 V
C102	Ceramic	0.0047 μF 50 V
C103	Ceramic	0.0047 μF 50 V
C104	Ceramic	1 pF 50 V CK
C105	Ceramic	1 pF 50 V CK
C106	Ceramic	0.001 μF 50 V
C107	Ceramic	0.001 μF 50 V
C108	Ceramic	0.001 μF 50 V
C109	Ceramic	0.0047 μF 50 V
C110	Electrolytic	10 μF 16 V MS7
C111	Ceramic	0.01 μF 50 V
C112	Barrier Layer	0.1 μF 16 V
C113	Ceramic	0.0047 μF 50 V
C115	Ceramic	200 pF 50 V
C116	Ceramic	220 pF 50 V
C117	Ceramic	100 pF 50 V
C118	Ceramic	220 pF 50 V
C119	Ceramic	470 pF 50 V
C120	Ceramic	82 pF 50 V
C121	Barrier Layer	0.0012 μF 25 V
C122	Ceramic	150 pF 50 V
C123	Ceramic	75 pF 50 V
C124	Ceramic	18 pF 50 V
C125	Ceramic	120 pF 50 V
C126	Ceramic	47 pF 50 V
C127	Ceramic	100 pF 50 V
C128	Ceramic	0.0047 μF 50 V
C129	Ceramic	0.0047 μF 50 V
C130	Ceramic	0.0047 μF 50 V
C131	Ceramic	0.01 μF 50 V
C132	Barrier Layer	0.047 μF 25 V
C133	Barrier Layer	0.0047 μF 25 V
C134	Ceramic	0.001 μF 50 V
C135	Ceramic	0.001 μF 50 V
C136	Ceramic	75 pF 50 V
C137	Ceramic	18 pF 50 V
C138	Ceramic	120 pF 50 V
C139	Ceramic	47 pF 50 V
C140	Ceramic	100 pF 50 V
C141	Ceramic	100 pF 50 V
C142	Ceramic	100 pF 50 V
C143	Ceramic	3 pF 50 V
C144	Ceramic	33 pF 50 V
C145	Ceramic	33 pF 50 V
C146	Ceramic	51 pF 50 V
C147	Ceramic	62 pF 50 V
C148	Ceramic	180 pF 50 V
C149	Ceramic	120 pF 50 V
C150	Ceramic	0.0047 μF 50 V
C151	Barrier Layer	0.0047 μF 25 V
C152	Ceramic	0.0047 μF 50 V
C153	Ceramic	0.001 μF 50 V
C154	Ceramic	0.001 μF 50 V
C155	Barrier Layer	0.047 μF 25 V
C157	Ceramic	0.01 μF 50 V
C158	Tantalum	0.1 μF 35 V DN
C159	Ceramic	10 pF 50 V PH
C160	Trimmer	6 pF CV05A0601
C161	Ceramic	10 pF 50 V CH

[PLL-B UNIT]

REF. NO.	DESCRIPTION	PART NO.
C162	Ceramic	56 pF 50 V CH
C163	Ceramic	27 pF 50 V CH
C164	Ceramic	8 pF 50 V CH
C165	Electrolytic	10 μF 16 V MS7
C166	Ceramic	0.0047 μF 50 V
C167	Ceramic	1 pF 50 V CK
C168	Ceramic	0.0047 μF 50 V
C169	Ceramic	0.001 μF 50 V
C170	Ceramic	0.0047 μF 50 V
C171	Ceramic	0.0047 μF 50 V
C172	Ceramic	0.001 μF 50 V
C173	Ceramic	10 pF 50 V
C174	Ceramic	0.5 pF 50 V
C175	Ceramic	10 pF 50 V
C176	Barrier Layer	0.01 μF 25 V
C177	Ceramic	0.0047 μF 50 V
C178	Ceramic	0.001 μF 50 V
C184	Barrier Layer	0.1 μF 16 V
C186	Barrier Layer	0.1 μF 16 V
C187	Electrolytic	10 μF 16 V MS7
C188	Barrier Layer	0.1 μF 16 V
C189	Barrier Layer	0.1 μF 16 V
C190	Ceramic	100 pF 50 V
C191	Ceramic	220 pF 50 V
C192	Ceramic	100 pF 50 V
C193	Barrier Layer	0.1 μF 16 V
C194	Barrier Layer	0.1 μF 16 V
C195	Barrier Layer	0.0047 μF 25 V
C196	Electrolytic	10 μF 16 V MS7
C197	Barrier Layer	0.1 μF 16 V
C198	Ceramic	0.0047 μF 50 V
C199	Cylinder	0.0047 μF EP050X 472N-NA
C200	Ceramic	0.0047 μF 50 V
C201	Ceramic	68 pF 50 V
C202	Ceramic	18 pF 50 V
C203	Ceramic	6 pF 50 V
C204	Ceramic	120 pF 50 V
C205	Ceramic	6 pF 50 V
C206	Ceramic	10 pF 50 V
C207	Ceramic	68 pF 50 V
C208	Barrier Layer	0.0047 μF 25 V
C209	Barrier Layer	0.0047 μF 25 V
C210	Ceramic	0.001 μF 50 V
C270	Electrolytic	10 μF 16 V MS7
C271	Barrier Layer	0.047 μF 25 V
C272	Barrier Layer	0.0047 μF 25 V
C273	Ceramic	0.001 μF 50 V
C274	Ceramic	0.001 μF 50 V
C275	Ceramic	0.001 μF 50 V
C286	Ceramic	0.0047 μF 50 V
C287	Ceramic	0.0047 μF 50 V
C288	Ceramic	0.001 μF 50 V
C289	Ceramic	0.0047 μF 50 V
C290	Ceramic	12 pF 50 V
C291	Ceramic	0.0047 μF 50 V
C296	Barrier Layer	0.1 μF 16 V
C300	Ceramic	0.001 μF GRM40
C301	Ceramic	0.01 μF GRM40 F
C302	Ceramic	0.1 μF GRM40 F
C303	Barrier Layer	0.047 μF 25 V
C304	Ceramic	56 pF 50 V
J1	Connector	TLB-P04H-B1
J2	Connector	TLB-P03H-B1
J3	Connector	TLB-P06H-B1
J8	Connector	TMP-J01X-V6
J9	Connector	TMP-J01X-V6
J11	Connector	TMP-J01X-V6
P1	Connector	TL25H-05-B1
P2	Connector	TL25H-04-B1
P3	Connector	TL25H-06-B1
P4	Connector	TL25H-05-B1

[PLL-B UNIT]

REF. NO.	DESCRIPTION	PART NO.
P5	Connector	TMP-P01X-A1
EP1	P.C. Board	B-1335A (PLL-B)
EP2	P.C. Board	B-1515B (EP2)
W138	Jumper	JPW-02H

[DDS-B UNIT]

REF. NO.	DESCRIPTION	PART NO.
IC1	IC	SC-1051
IC2	IC	SC-1052
IC3	IC	SC-1053
IC4	IC	TC74HCT374F
IC5	IC	TC74HCT374F
L1	Coil	LQN5N331K 330μ
L2	Coil	LQN5N331K 330μ
L3	Coil	LQN5N331K 330μ
R3	Resistor	2.2 kΩ MCR10
R4	Array	GF5096
C3	Ceramic	0.1 μF GRM40 F
C7	Ceramic	68 pF GRM40
C8	Ceramic	2 pF GRM40
C9	Ceramic	120 pF GRM40
C10	Ceramic	7 pF GRM40
C11	Ceramic	120 pF GRM40
C12	Ceramic	12 pF GRM40
C13	Ceramic	68 pF GRM40
C14	Ceramic	0.1 μF GRM40 F
C15	Ceramic	0.1 μF GRM40 F
C16	Ceramic	0.1 μF GRM40 F
C17	Ceramic	0.1 μF GRM40 F
C19	Ceramic	0.001 μF GRM40
C20	Ceramic	220 pF GRM40
J1	Connector	3022-03A
J2	Connector	3022-06A
EP1	P.C. Board	B-1233C

[LOGIC-A UNIT]

REF. NO.	DESCRIPTION	PART NO.
IC1	IC	μPD71055C
IC2	IC	μPD71055C
IC3	IC	μPD71055C
IC4	IC	μPD74HC42C
IC5	IC	SC-1094
IC6	IC	μPD4364C
IC7	IC	HD64B180ROP
IC8	IC	RP5C15
IC9	IC	μPD74HC244C
IC10	IC	μPD74HC367C

[LOGIC-A UNIT]

REF. NO.	DESCRIPTION	PART NO.
IC11	IC	μPD74HC367C
IC12	IC	μPD4024BC
IC13	IC	μPD4520BC
IC14	IC	μPD74HC32C
IC15	IC	μPD4011BC
IC16	IC	μPD74HC32C
IC17	IC	TC74HC00P
IC18	IC	μPD4528BC
IC19	IC	M54562P
IC20	IC	S-8054ALB
Q1	Transistor	2SC2458 Y
Q2	Transistor	2SC2458 Y
Q3	Transistor	2SC2458 Y
Q4	Transistor	2SC2458 Y
Q5	Transistor	RN1204
Q6	Transistor	2SA1048 Y
Q7	Transistor	2SA1048 Y
Q8	Transistor	RN1204
Q9	Transistor	2SC1214
Q10	Transistor	2SC2785 EF
Q11	Transistor	2SC2785 EF
Q12	Transistor	2SC2785 EF
Q13	Transistor	2SC2785 EF
D1	Diode	1SS53
D2	Diode	1SS133
D3	Diode	1SS133
D4	Diode	1SS53
D5	Diode	1SS133
D6	Diode	1SS133
D7	Diode	1SS133
D8	Diode	1SS133
X1	Crystal	RF4A3 FAF
X2	Crystal	NC-38 (32.768 kHz)
L1	Coil	LAL03NA 101K
L2	Coil	LAL02NA 100K
L3	Coil	LAL02NA 100K
L4	Coil	LAL02NA 100K
L5	Coil	LAL02NA 100K
L6	Coil	LAL03NA 101K
R1	Resistor	1 kΩ R20
R2	Resistor	1 kΩ R20
R3	Resistor	1 kΩ R20
R4	Resistor	1 kΩ R20
R5	Resistor	1 kΩ R20
R6	Resistor	1 kΩ R20
R7	Resistor	1 kΩ R20
R8	Resistor	1 kΩ R20
R9	Resistor	1 kΩ R20
R10	Resistor	1 kΩ R20
R11	Resistor	1 kΩ R20
R12	Resistor	1 kΩ R20
R13	Resistor	4.7 kΩ ELR20
R14	Resistor	4.7 kΩ ELR20
R15	Resistor	4.7 kΩ ELR20
R16	Resistor	4.7 kΩ ELR20
R17	Resistor	4.7 kΩ ELR20
R18	Resistor	4.7 kΩ ELR20
R19	Resistor	4.7 kΩ ELR20
R20	Resistor	4.7 kΩ ELR20
R21	Resistor	1 kΩ R20
R22	Resistor	1 kΩ R20
R23	Resistor	1 kΩ R20
R24	Resistor	1 kΩ R20
R25	Resistor	1 kΩ R20
R26	Resistor	1 kΩ R20



[LOGIC-A UNIT]

REF. NO.	DESCRIPTION	PART NO.	
R27	Resistor	1 kΩ	R20
R28	Resistor	1 kΩ	R20
R29	Resistor	1 kΩ	R20
R30	Resistor	1 kΩ	R20
R31	Resistor	1 kΩ	R20
R32	Array	10 kΩ	RMX-4
R33	Resistor	10 kΩ	R20
R34	Resistor	47 kΩ	ELR20
R35	Resistor	10 kΩ	R20
R36	Resistor	10 kΩ	R20
R37	Resistor	10 kΩ	R20
R38	Resistor	2.2 kΩ	R20
R39	Resistor	4.7 kΩ	R20
R40	Resistor	47 kΩ	R20
R41	Resistor	47 kΩ	R20
R42	Resistor	10 kΩ	R20
R43	Resistor	10 kΩ	R20
R44	Resistor	1 kΩ	R20
R45	Resistor	4.7 kΩ	R20
R46	Resistor	10 kΩ	R20
R47	Resistor	100 kΩ	R25
R48	Resistor	10 kΩ	ELR20
R49	Resistor	47 kΩ	ELR20
R50	Resistor	47 kΩ	ELR20
R51	Resistor	47 kΩ	R20
R52	Resistor	680 kΩ	R20
R53	Resistor	68 kΩ	R20
R54	Resistor	470 Ω	R20
R55	Resistor	470 Ω	R20
R56	Resistor	470 Ω	R20
R57	Resistor	470 Ω	R20
R58	Resistor	470 Ω	R20
R59	Resistor	470 Ω	R20
R60	Resistor	470 Ω	R20
R61	Resistor	470 Ω	R20
R62	Resistor	470 Ω	R20
R63	Resistor	470 Ω	R20
R64	Resistor	470 Ω	R20
R65	Resistor	470 Ω	R20
R66	Resistor	1 kΩ	R20
R67	Resistor	220 kΩ	ELR20
R68	Resistor	10 kΩ	R20
R69	Resistor	1 kΩ	ELR20
R70	Resistor	2.2 kΩ	ELR20
R71	Resistor	1 kΩ	ELR20
R72	Resistor	220 Ω	ELR20
R73	Resistor	4.7 kΩ	ELR20
R74	Resistor	4.7 kΩ	ELR20
R75	Resistor	4.7 kΩ	ELR20
R76	Resistor	4.7 kΩ	ELR20
R77	Resistor	4.7 kΩ	R20
R78	Resistor	4.7 kΩ	R20
R79	Resistor	4.7 kΩ	R20
R80	Resistor	4.7 kΩ	R20
R81	Resistor	1 kΩ	R20
R82	Resistor	1 kΩ	R20
R83	Resistor	100 Ω	ELR20
R84	Resistor	47 kΩ	ELR20
R85	Array	10 kΩ	RMX-4
C1	Array	0.0022 μF × 4	B5RC0125-32N
C2	Array	0.0022 μF × 4	B5RC0125-32N
C3	Array	0.0022 μF × 4	B5RC0125-32N
C4	Array	470 pF × 4	B5RC0123-32N
C5	Array	470 pF × 4	B5RC0123-32N
C6	Array	0.001 μF × 6	B7ZC0716-32N
C7	Array	0.001 μF × 6	B7ZC0716-32N
C8	Barrier Layer	0.1 μF	16 V
C9	Barrier Layer	0.1 μF	16 V
C10	Barrier Layer	0.1 μF	16 V
C11	Barrier Layer	0.1 μF	16 V
C12	Barrier Layer	0.1 μF	16 V
C13	Barrier Layer	0.1 μF	16 V
C14	Barrier Layer	0.1 μF	16 V

[LOGIC-A UNIT]

REF. NO.	DESCRIPTION	PART NO.	
C15	Ceramic	39 pF	50 V
C16	Ceramic	5 pF	50 V
C17	Trimmer	20 pF	CV38D2001
C18	Barrier Layer	0.1 μF	16 V
C19	Barrier Layer	0.1 μF	16 V
C20	Barrier Layer	0.1 μF	16 V
C21	Barrier Layer	0.1 μF	16 V
C22	Barrier Layer	0.1 μF	16 V
C23	Barrier Layer	0.1 μF	16 V
C24	Ceramic	47 pF	50 V
C25	Barrier Layer	0.1 μF	16 V
C26	Barrier Layer	0.1 μF	16 V
C27	Barrier Layer	0.1 μF	16 V
C28	Barrier Layer	0.1 μF	16 V
C29	Ceramic	10 pF	50 V
C30	Ceramic	10 pF	50 V
C31	Barrier Layer	0.1 μF	16 V
C32	Mylar	0.15 μF	50 V F2D
C33	Barrier Layer	0.1 μF	16 V
C34	Mylar	0.01 μF	50 V F2D
C35	Ceramic	330 pF	50 V
C36	Barrier Layer	0.1 μF	16 V
C37	Ceramic	330 pF	50 V
C38	Electrolytic	100 μF	10 V SS
C39	Electrolytic	22 μF	10 V SS
C40	Ceramic	0.0047 μF	50 V
C41	Electrolytic	100 μF	10 V SS
C42	Barrier Layer	0.01 μF	25 V
C43	Electrolytic	100 μF	10 V SS
C44	Barrier Layer	0.01 μF	25 V
C45	Array	470 pF × 4	B5RC0123-32N
C46	Array	470 pF × 4	B5RC0123-32N
C47	Electrolytic	100 μF	10 V SS
C48	Ceramic	0.0047 μF	50 V
C49	Ceramic	0.0047 μF	50 V
C50	Ceramic	0.0047 μF	50 V
J1	Connector	TLB-P13H-B1	
J2	Connector	TLB-P10H-B1	
J3	Connector	TLB-P08H-B1	
J4	Connector	TLB-P07H-B1	
J5	Connector	TL25P-05-V1	
J6	Connector	TL25P-03-V1	
J7	Connector	TL25P-04-V1	
J8	Connector	TL25P-04-V1	
J9	Connector	TL25P-12-V1	
J10	Connector	TL25P-05-V1	
J11	Connector	TL25P-11-V1	
J12	Connector	TL25P-05-V1	
J13	Connector	TL25P-05-V1	
J14	Connector	TLB-P03H-B1	
J15	Connector	TL25P-06-V1	
P1	Connector	TL25H-12-B1	
P2	Connector	TL25H-10-B1	
P3	Connector	TL25H-08-B1	
P4	Connector	TL25H-07-B1	
P5	Connector	W1	
P6	Connector	TL25H-05-B1	
P7	Connector	TMP-P01X-A1	
BT1	Lithium Battery	BR2032-1T2	
EP1	P.C. Board	B-1339C	
W3	Jumper	JPW-02A	
W4	Jumper	JPW-02A	
W53	Jumper	JPW-02A	

[CRTC UNIT]

REF. NO.	DESCRIPTION	PART NO.
IC1	IC	RF5C16A
IC2	IC	SN74LS07NS
IC3	IC	HM50464CP-12
IC4	IC	HM50464CP-12
IC5	IC	HM50464CP-12
IC6	IC	HM50464CP-12
Q1	Transistor	2SC2712 Y
D1	Diode	1SS187
X1	Crystal	RF4A3 FAK (14.31818 MHz)
L1	Coil	FL5H 220K
L2	Coil	LQN5N331K 330μ
L3	Coil	LQH3N2R2M 2.2μ
L4	Coil	LQH3N2R2M 2.2μ
R1	Resistor	100 kΩ MCR10
R2	Resistor	18 Ω MCR10
R3	Resistor	18 Ω MCR10
R4	Resistor	18 Ω MCR10
R5	Resistor	18 Ω MCR10
R6	Resistor	18 Ω MCR10
R7	Resistor	18 Ω MCR10
R8	Resistor	18 Ω MCR10
R9	Resistor	18 Ω MCR10
R10	Resistor	18 Ω MCR10
R11	Resistor	18 Ω MCR10
R12	Resistor	18 Ω MCR10
R13	Resistor	18 Ω MCR10
R14	Resistor	150 Ω MCR10
R15	Resistor	1.2 kΩ MCR10
R16	Resistor	680 Ω MCR10
R17	Resistor	470 Ω MCR10
R18	Resistor	330 Ω MCR10
R19	Resistor	220 Ω MCR10
R20	Resistor	680 Ω MCR10
R21	Resistor	68 Ω MCR10
R22	Resistor	100 Ω MCR10
C1	Ceramic	47 pF GRM40
C2	Ceramic	47 pF GRM40
C3	Ceramic	0.01 μF GRM40 F
C4	Tantalum	15 μF 10 V SV
C5	Ceramic	0.001 μF GRM40
C6	Ceramic	470 pF GRM40
C7	Ceramic	0.001 μF GRM40
C8	Ceramic	470 pF GRM40
C9	Tantalum	15 μF 10 V SV
C10	Ceramic	0.001 μF GRM40
C11	Electrolytic	100 μF 10 V RC2
C12	Ceramic	0.01 μF GRM40 F
J1	Connector	3022-04B
J2	Connector	3022-09B
J3	Connector	3022-06B
EP1	P.C. Board	B-1336A

[LOGIC-B UNIT]

REF. NO.	DESCRIPTION	PART NO.
IC1	IC	μPD75104CW-117
IC2	IC	μPD4011BC
IC3	IC	μPD4001BC
IC4	IC	μPD4011BC
IC5	IC	μPD4001BC
IC6	IC	μPD4011BC
IC7	IC	μPD4071BC
IC8	IC	μPD4001BC
IC9	IC	μPD4011BC
IC10	IC	μPD4011BC
IC11	IC	μPD4011BC
IC12	IC	μPD4028BC
IC13	IC	M54562P
IC14	IC	M50784SP
IC15	IC	M54562P
IC16	IC	μPD4011BC
IC17	IC	DAN401
IC18	IC	DAN401
IC19	IC	DAN401
IC20	IC	DAN401
IC21	IC	NJM7805A
IC22	IC	NJM7809A
Q1	Transistor	2SA1048 Y
Q2	Transistor	2SC2458 GR
D1	Diode	1SS133
D2	Diode	1SS133
D5	Diode	1SS133
D6	Diode	1SS133
D7	Diode	1SS133
D8	Diode	1SS133
D9	Diode	1SS133
D10	Diode	1SS133
D11	Diode	1SS133
D12	Diode	1SS133
D13	Diode	1SS133
D14	Diode	1SS133
D18	Diode	1SS133
D19	Diode	1SS133
D20	Diode	1SS133
D21	Diode	1SS133
D22	Diode	1SS133
D23	Diode	1SS133
D24	Diode	1SS133
D27	Zener	RD8.2E B3
D28	Diode	1SS133
D29	Diode	1SS133
D30	Diode	1SS133
D31	Diode	1SS133
D32	Diode	1SS133
D33	Diode	1SS133
D34	Diode	1SS133
D35	Diode	1SS133
D36	Diode	1SS133
D37	Diode	1SS53
D38	Diode	1SS53
X1	Crystal	RF4A3 FAC (4.1953 MHz)
L1	Coil	LW-12A
L2	Coil	BT01RN1-A61
L3	Coil	LAL04NA 101K
L4	Coil	LAL03NA 101K
L11	Coil	LAL03NA 101K
L12	Coil	LAL03NA 101K
L13	Coil	LAL03NA 101K
L14	Coil	LAL03NA 101K
L15	Coil	LAL04NA 101K
L16	Coil	LAL04NA 101K
L17	Coil	LAL04NA 101K

[LOGIC-B UNIT]

REF. NO.	DESCRIPTION	PART NO.	
L18	Coil	LAL04NA	101K
L19	Coil	LAL04NA	101K
L20	Coil	LAL04NA	101K
L21	Coil	LAL04NA	101K
L22	Coil	LAL03NA	101K
L23	Coil	LAL04NA	101K
L25	Coil	LAL03NA	100K
L26	Coil	BT01RN1-A61	
L27	Coil	LAL03NA	100K
R1	Array	47 kΩ	RMX-4
R2	Resistor	47 kΩ	ELR20
R3	Resistor	47 kΩ	ELR20
R4	Resistor	47 kΩ	ELR20
R5	Array	47 kΩ	RMX-4
R6	Resistor	47 kΩ	ELR20
R7	Resistor	47 kΩ	ELR20
R8	Resistor	47 kΩ	ELR20
R9	Resistor	47 kΩ	R20
R10	Resistor	47 kΩ	R20
R11	Array	47 kΩ	RMX-4
R12	Resistor	47 kΩ	ELR20
R13	Resistor	47 kΩ	ELR20
R14	Resistor	47 kΩ	R20
R16	Resistor	3.3 MΩ	ELR25
R17	Resistor	68 kΩ	ELR20
R23	Resistor	4.7 kΩ	CRB25FX
R24	Resistor	750 Ω	CRB25FX
R25	Resistor	1.8 kΩ	CRB25FX
R26	Resistor	3.3 kΩ	CRB25FX
R27	Resistor	5.6 kΩ	CRB25FX
R28	Resistor	10 kΩ	CRB25FX
R29	Resistor	1 kΩ	ELR20
R30	Resistor	1 kΩ	ELR20
R31	Resistor	1 kΩ	ELR20
R32	Resistor	1 kΩ	ELR20
R33	Resistor	1 kΩ	ELR20
R34	Resistor	1 kΩ	ELR20
R35	Resistor	1 kΩ	ELR20
R36	Resistor	47 kΩ	ELR20
R37	Resistor	47 kΩ	ELR20
R38	Resistor	47 kΩ	R20
R39	Array	47 kΩ	RMX-7
R40	Array	47 kΩ	RMX-8
R41	Array	100 kΩ	RKM10L
R42	Resistor	1 kΩ	ELR20
R43	Resistor	1 kΩ	ELR20
R44	Resistor	1 kΩ	ELR20
R45	Resistor	1 kΩ	ELR20
R46	Resistor	1 kΩ	ELR20
R47	Resistor	1 kΩ	ELR20
R48	Resistor	1 kΩ	ELR20
R49	Resistor	1 kΩ	ELR20
R50	Resistor	1 kΩ	R20
R51	Resistor	1 kΩ	R20
R52	Resistor	1 kΩ	R20
R53	Resistor	1 kΩ	R20
R54	Resistor	1 kΩ	ELR20
R55	Resistor	1 kΩ	ELR20
R56	Resistor	1 kΩ	ELR20
R57	Resistor	1 kΩ	ELR20
R58	Resistor	1 kΩ	ELR20
R59	Resistor	1 kΩ	ELR20
R60	Resistor	1 kΩ	ELR20
R61	Resistor	1 kΩ	ELR20
R62	Resistor	1 kΩ	ELR20
R63	Resistor	1 kΩ	ELR20
R64	Resistor	1 kΩ	ELR20
R65	Resistor	1 kΩ	ELR20
R66	Resistor	2.2 MΩ	ELR20
R67	Resistor	330 kΩ	ELR20
R68	Resistor	2.2 MΩ	ELR20
R69	Resistor	220 kΩ	ELR20
R70	Resistor	1 kΩ	R20

[LOGIC-B UNIT]

REF. NO.	DESCRIPTION	PART NO.	
R71	Resistor	1 kΩ	ELR20
R72	Resistor	1 kΩ	ELR20
R73	Resistor	1 kΩ	ELR20
R74	Resistor	1 kΩ	ELR20
R75	Resistor	47 kΩ	R20
R76	Resistor	47 kΩ	R20
R77	Resistor	1 kΩ	ELR20
R78	Resistor	47 kΩ	ELR20
R79	Resistor	1 kΩ	R20
R80	Resistor	1 kΩ	ELR20
R81	Array	10 kΩ	RMX-4
R82	Resistor	10 kΩ	R20
R83	Resistor	10 kΩ	R20
R84	Resistor	10 kΩ	ELR20
R85	Resistor	10 kΩ	ELR20
R86	Resistor	22 kΩ	ELR25
R87	Resistor	470 kΩ	ELR20
R88	Resistor	22 kΩ	ELR20
R89	Resistor	22 kΩ	ELR20
R90	Resistor	1 kΩ	ELR20
R91	Resistor	1 kΩ	R20
R92	Resistor	100 Ω	R20
C1	Ceramic	0.001 μF	50 V
C2	Ceramic	0.001 μF	50 V
C3	Ceramic	0.001 μF	50 V
C4	Ceramic	0.001 μF	50 V
C5	Ceramic	100 pF	50 V
C6	Ceramic	0.001 μF	50 V
C7	Ceramic	0.001 μF	50 V
C8	Ceramic	0.001 μF	50 V
C9	Ceramic	0.001 μF	50 V
C10	Ceramic	100 pF	50 V
C11	Ceramic	0.001 μF	50 V
C12	Ceramic	0.001 μF	50 V
C13	Ceramic	0.001 μF	50 V
C14	Ceramic	0.001 μF	50 V
C15	Ceramic	100p μF	50 V
C16	Electrolytic	0.47 μF	50 V SS
C19	Barrier Layer	0.047 μF	25 V
C20	Barrier Layer	0.047 μF	25 V
C21	Array	0.0082 μF × 7	B8ZC0111-32N
C22	Barrier Layer	0.047 μF	25 V
C23	Barrier Layer	0.047 μF	25 V
C24	Ceramic	27 pF	50 V
C25	Barrier Layer	27 pF	50 V
C26	Array	470 pF × 4	B5RC0123-32N
C27	Array	470 pF × 4	B5RC0123-32N
C28	Ceramic	0.01 μF	50 V
C29	Ceramic	0.01 μF	50 V
C30	Array	0.0047 μF × 6	B7ZC0714-32N
C31	Array	0.0082 μF × 7	B8ZC0111-32N
C32	Barrier Layer	0.015 μF	25 V
C33	Barrier Layer	0.01 μF	25 V
C34	Barrier Layer	0.047 μF	25 V
C35	Barrier Layer	0.047 μF	25 V
C36	Barrier Layer	0.047 μF	25 V
C37	Barrier Layer	0.047 μF	25 V
C38	Barrier Layer	0.047 μF	25 V
C39	Barrier Layer	0.047 μF	25 V
C40	Barrier Layer	0.047 μF	25 V
C41	Barrier Layer	0.047 μF	25 V
C42	Electrolytic	22 μF	25 V SS
C43	Electrolytic	1 μF	50 V MS7
C44	Electrolytic	100 μF	10 V SS
C45	Electrolytic	100 μF	16 V SS
C46	Ceramic	0.0047 μF	50 V
C47	Ceramic	0.0047 μF	50 V
C48	Barrier Layer	0.047 μF	25 V
C49	Barrier Layer	0.047 μF	25 V
C50	Barrier Layer	0.047 μF	25 V
C51	Electrolytic	47 μF	16 V SS
C52	Ceramic	0.0047 μF	50 V
C53	Ceramic	0.0047 μF	50 V

**[LOGIC-B UNIT]**

REF. NO.	DESCRIPTION	PART NO.
C54	Electrolytic	2.2 μF 50 V RC2
J1	Connector	TL25P-06-V1
J2	Connector	TL25P-04-V1
J3	Connector	TL25P-06-V1
J4	Connector	TL25P-07-V1
J5	Connector	TL25P-08-V1
J6	Connector	TL25P-05-V1
J7	Connector	TL25P-03-V1
J8	Connector	TL25P-12-V1
J9	Connector	TL25P-09-V1
J10	Connector	TL25P-10-V1
J11	Connector	TL25P-08-V1
J12	Connector	TL25P-04-V1
J13	Connector	TL25P-03-V1
J14	Connector	TL25P-05-V1
J15	Connector	TL25P-07-V1
J16	Connector	TL25P-04-V1
J17	Connector	TL25P-09-V1
J18	Connector	TL25P-04-V1
J19	Connector	TL25P-08-V1
J21	Connector	TL25P-05-V1
J22	Connector	TL25P-07-V1
J23	Connector	TL25P-04-V1
J24	Connector	5045-03A
J25	Connector	TL25P-03-V1
J26	Connector	TL25P-08-V1
J27	Connector	TLB-P03H-B1
J29	Connector	TL25P-05-V1
P1	Connector	EHR-05
S1	Switch	SSSS31124A (5 kHz ↔ 2.5 kHz)
BT1	Lithium Battery	BR2032-1T2
EP1	P.C. Board	B-1340D
EP2	Ferrite Bead	FSQH050RN
W6	Jumper	JPW-02A
W7	Jumper	JPW-02A
W10	Jumper	JPW-02A

**[SCOPE UNIT]**

REF. NO.	DESCRIPTION	PART NO.
Q3	Transistor	2SC2668 Y
Q4	FET	2SK241 GR
Q5	Transistor	2SC763 C
Q6	Transistor	2SC2053
Q7	FET	2SK241 GR
Q8	Transistor	2SC2458 GR
Q9	Transistor	2SA1048 GR
Q10	FET	2SK241 GR
Q11	Transistor	2SC2458 GR
Q12	Transistor	RN1204
Q13	Transistor	RN1204
Q14	Transistor	RN2202
Q15	Transistor	2SB562 C
Q16	Transistor	2SA798 G
Q17	Transistor	2SD468 C
Q18	Transistor	RN1204
D1	Diode	M1204
D2	Diode	M1204
D3	Zener	RD5.1E B2
D4	Diode	1S953
D5	Diode	1S953
D6	Diode	1SS133
D7	Diode	1SS133
D8	Diode	1K60
D9	Diode	1K60
D10	Diode	1SS133
D11	Diode	1S953
D12	Diode	1S953
D13	Diode	1SS133
D14	Diode	1SS133
D15	Varicap	SVC321 A
D16	Diode	1SS133
D17	Diode	1SS133
D18	Diode	1SS133
D19	Diode	1SS133
D20	Diode	1S953
X1	Crystal	CR-115
X2	Ceramic Resonator	CSB400 A
X3	Ceramic Resonator	CSB400 A
L1	Coil	LAL03NA 100K
L2	Coil	LAL03NA 100K
L3	Coil	LA-263
L4	Coil	LA-256
L5	Coil	LS-254
L6	Coil	LS-254
L7	Coil	LS-114
L8	Coil	LR-116
L9	Coil	LR-116
L10	Coil	LS-114
L11	Coil	LS-114
L12	Coil	LAL03NA 120K
L13	Coil	LAL03NA 100K
L14	Coil	LAL03NA 2R7M
L15	Coil	LAL03NA 6R8K
L16	Coil	LS-195
L17	Coil	LS-195
L18	Coil	LS-195
L19	Coil	LR-116
L20	Coil	LR-116
L21	Coil	LR-116
L22	Coil	LS-195
L23	Coil	LS-195
L24	Coil	LS-195
L25	Coil	LS-195
L26	Coil	LAL03MA 181K
L27	Coil	LAL03NA 181K
L28	Coil	LAL03NA 181K
L29	Coil	LS-238
L30	Coil	LS-238

**[SCOPE UNIT]**

REF. NO.	DESCRIPTION	PART NO.
IC1	IC	ND487C2-3R
IC2	IC	HD10551
IC3	IC	NJM4558D
IC4	IC	ND487C1-3R
IC5	IC	μPC1037H
IC6	IC	NJM2204AD
IC7	IC	NJM4558D
IC8	IC	TC35094P
IC9	IC	μPD4011BC
IC10	IC	μPD4052BC
IC11	IC	NJM4558D
IC12	IC	NJM78L05A
Q1	FET	2SK241 GR
Q2	Transistor	2SC2053



[SCOPE UNIT]

REF. NO.	DESCRIPTION	PART NO.
L31	Coil	LS-238
L32	Coil	LR-116
L33	Coil	LS-238
L34	Coil	LS-238
L35	Coil	LR-116
L36	Coil	LAL03NA 220K
L37	Coil	LAL03NA 180K
L38	Coil	LAL03NA 330K
L39	Coil	LAL03NA 102K
L40	Coil	LAL03NA 102K
L41	Coil	LAL03NA 561K
L42	Coil	LAL03NA 561K
L43	Coil	LS-251A
L44	Coil	LAL03NA 102K
L46	Coil	LAL04NA 101K
L47	Coil	LAL03NA 101K
L48	Coil	LAL04NA 100K
L49	Coil	LAL03NA 100K
L50	Coil	LAL03NA 561K
L51	Coil	LAL03NA 561K
L52	Coil	LAL03NA 561K
L53	Coil	LAL03NA 561K
R1	Resistor	1.2 kΩ ELR20
R2	Resistor	470 Ω R20
R3	Resistor	47 Ω ELR20
R4	Resistor	4.7 kΩ R20
R6	Resistor	10 kΩ R20
R9	Resistor	2.2 MΩ R20
R10	Resistor	1.5 kΩ R20
R11	Resistor	150 Ω R20
R12	Resistor	270 Ω ELR20
R13	Resistor	18 Ω ELR20
R14	Resistor	270 Ω R25
R15	Resistor	22 Ω R20
R16	Resistor	33 Ω R25
R17	Resistor	4.7 Ω ELR20
R18	Resistor	4.7 kΩ ELR20
R19	Resistor	220 Ω ELR20
R20	Resistor	820 Ω R20
R21	Resistor	220 Ω R20
R22	Resistor	1 kΩ ELR20
R23	Resistor	10 kΩ R20
R24	Resistor	4.7 kΩ ELR20
R25	Resistor	68 Ω R20
R26	Resistor	1 kΩ ELR20
R27	Resistor	330 Ω ELR20
R28	Resistor	470 Ω ELR20
R29	Resistor	10 kΩ R20
R30	Resistor	10 kΩ ELR20
R31	Resistor	1.5 MΩ ELR20
R32	Resistor	100 Ω R20
R33	Resistor	680 kΩ ELR20
R34	Resistor	100 kΩ R20
R35	Resistor	560 kΩ R20
R36	Resistor	5.6 kΩ ELR20
R37	Resistor	2.2 MΩ R20
R38	Resistor	150 Ω ELR20
R39	Resistor	10 kΩ R25
R42	Resistor	47 Ω R20
R43	Resistor	4.7 kΩ R20
R44	Resistor	100 Ω ELR20
R45	Resistor	4.7 kΩ R20
R46	Resistor	1.5 kΩ ELR20
R47	Resistor	47 Ω R20
R48	Trimmer	470 kΩ RH0651CS2J1HA
R49	Resistor	33 Ω R20
R50	Resistor	4.7 kΩ ELR20
R51	Resistor	4.7 Ω ELR20
R52	Resistor	820 Ω ELR20
R53	Resistor	150 Ω R20
R54	Resistor	1 kΩ R20
R55	Resistor	100 kΩ ELR20
R56	Resistor	22 kΩ R20

[SCOPE UNIT]

REF. NO.	DESCRIPTION	PART NO.
R57	Resistor	4.7 kΩ ELR20
R58	Resistor	220 Ω ELR20
R59	Resistor	220 Ω ELR20
R60	Resistor	100 kΩ ELR20
R61	Resistor	100 kΩ ELR20
R62	Resistor	560 kΩ R20
R63	Resistor	120 kΩ R20
R64	Resistor	1 MΩ ELR20
R65	Resistor	100 Ω R25
R66	Resistor	22 kΩ R25
R67	Resistor	10 kΩ R20
R68	Resistor	12 kΩ R20
R69	Resistor	22 kΩ ELR20
R70	Resistor	22 kΩ ELR20
R71	Resistor	22 kΩ R25
R72	Resistor	22 kΩ ELR20
R73	Resistor	10 kΩ R20
R74	Resistor	47 kΩ R20
R75	Trimmer	22 kΩ RH0651CJ4J01A
R76	Resistor	100 Ω R20
R77	Resistor	120 kΩ ELR20
R78	Resistor	100 Ω R25
R79	Resistor	1 kΩ R20
R80	Trimmer	470 Ω RH0651CS2J1HA
R81	Resistor	1 kΩ R20
R82	Resistor	2.2 kΩ R20
R83	Resistor	10 kΩ ELR20
R84	Resistor	33 kΩ R20
R85	Resistor	47 kΩ ELR20
R86	Resistor	10 kΩ R20
R87	Resistor	1 kΩ R20
R88	Resistor	1 kΩ R20
R89	Resistor	1 kΩ R20
R90	Resistor	1 kΩ R20
R91	Resistor	1 kΩ R20
R92	Resistor	1 kΩ R20
R93	Resistor	1 kΩ R20
R94	Resistor	1 kΩ R20
R95	Array	47 kΩ RMX-8
R96	Resistor	100 kΩ R20
R97	Resistor	68 kΩ R20
R98	Resistor	100 kΩ ELR20
R99	Resistor	100 kΩ ELR20
R100	Resistor	100 kΩ R20
R101	Resistor	100 kΩ R20
R102	Trimmer	47 kΩ RH0651CS4J25A
R103	Trimmer	22 kΩ RH0651CJ4J01A
R104	Trimmer	4.7 kΩ RH0651CS3J2KA
R105	Resistor	5.6 kΩ R20
R106	Resistor	27 kΩ ELR20
R107	Resistor	220 kΩ ELR20
R108	Resistor	22 Ω R20
R110	Resistor	47 kΩ R20
R111	Resistor	220 Ω R20
R112	Resistor	33 kΩ ELR20
R113	Resistor	22 kΩ R20
R114	Resistor	22 kΩ ELR20
R115	Resistor	1 kΩ ELR20
R117	Resistor	220 Ω R20
R118	Resistor	100 Ω R25
R119	Resistor	120 kΩ ELR20
R120	Resistor	100 Ω R20
R121	Resistor	47 kΩ R20
R122	Trimmer	10 kΩ RH0651C14J2WA
R123	Resistor	27 kΩ ELR20
R124	Resistor	1 kΩ ELR20
R125	Resistor	1 kΩ ELR20
R126	Resistor	33 kΩ ELR20
R127	Resistor	33 kΩ ELR20
R128	Resistor	2.2 kΩ ELR20
R129	Resistor	10 kΩ R25
R130	Resistor	1 MΩ R20
R131	Resistor	47 Ω R20
R132	Resistor	1 kΩ ELR20
R133	Resistor	1 kΩ R25

## [SCOPE UNIT]

REF. NO.	DESCRIPTION	PART NO.	
R134	Resistor	1 kΩ	R25
R135	Resistor	220 kΩ	R20
R136	Resistor	560 kΩ	R20
R137	Resistor	15 kΩ	R20
R138	Resistor	820 Ω	R20
R139	Thermistor	23D29	
R140	Thermistor	33D28	
R141	Thermistor	33D28	
R142	Resistor	47 kΩ	R25
R143	Resistor	1.5 MΩ	R20
C1	Ceramic	0.0047 μF	50 V
C2	Ceramic	0.0047 μF	50 V
C3	Ceramic	0.0047 μF	50 V
C4	Ceramic	0.0047 μF	50 V
C5	Ceramic	0.001 μF	50 V
C6	Ceramic	82 pF	50 V
C7	Ceramic	120 pF	50 V
C8	Ceramic	10 pF	50 V
C9	Ceramic	120 pF	50 V
C10	Ceramic	39 pF	50 V
C11	Ceramic	120 pF	50 V
C12	Ceramic	22 pF	50 V
C13	Ceramic	3 pF	50 V
C14	Ceramic	20 pF	50 V
C15	Ceramic	0.001 μF	50 V
C16	Ceramic	0.0047 μF	50 V
C17	Barrier Layer	0.1 μF	16 V
C18	Ceramic	0.0047 μF	50 V
C19	Ceramic	22 pF	50 V
C20	Ceramic	0.0047 μF	50 V
C21	Ceramic	18 pF	50 V
C22	Ceramic	0.0047 μF	50 V
C23	Ceramic	0.0047 μF	50 V
C24	Ceramic	33 pF	50 V
C25	Ceramic	0.0047 μF	50 V
C26	Electrolytic	10 μF	25 V SS
C27	Ceramic	0.0047 μF	50 V
C28	Ceramic	0.0047 μF	50 V
C29	Ceramic	0.0047 μF	50 V
C30	Ceramic	68 pF	50 V
C31	Ceramic	180 pF	50 V
C32	Ceramic	15 pF	50 V
C33	Ceramic	100 pF	50 V
C34	Ceramic	0.0047 μF	50 V
C35	Ceramic	0.0047 μF	50 V
C36	Electrolytic	10 μF	25 V SS
C37	Electrolytic	1 μF	50 V SS
C38	Ceramic	470 pF	50 V SL
C39	Barrier Layer	0.001 μF	25 V UAT04V 102K
C40	Ceramic	470 pF	50 V SL
C41	Ceramic	220 pF	50 V
C42	Barrier Layer	820 pF	50 V RAU08SA 821K
C44	Ceramic	120 pF	50 V
C45	Cylinder	4.7 pF	UP125SL 4R7K-NA
C46	Ceramic	120 pF	50 V
C47	Cylinder	6.8 pF	UP125SL 6R8K-NA
C48	Ceramic	120 pF	50 V
C49	Ceramic	0.0047 μF	50 V
C50	Barrier Layer	0.047 μF	25 V
C51	Barrier Layer	0.047 μF	25 V
C52	Ceramic	0.0047 μF	50 V
C53	Ceramic	150 pF	50 V
C54	Barrier Layer	0.1 μF	16 V
C55	Barrier Layer	0.047 μF	25 V
C56	Ceramic	0.0047 μF	50 V
C57	Ceramic	150 pF	50 V
C58	Cylinder	5.6 pF	UP125SL 5R6K-NA
C59	Ceramic	150 pF	50 V
C60	Cylinder	5.6 pF	UP125SL 5R6K-NA
C61	Ceramic	150 pF	50 V
C62	Ceramic	0.0047 μF	50 V
C63	Barrier Layer	0.1 μF	16 V
C64	Barrier Layer	0.1 μF	16 V

## [SCOPE UNIT]

REF. NO.	DESCRIPTION	PART NO.	
C65	Barrier Layer	0.047 μF	25 V
C66	Ceramic	330 pF	50 V
C67	Ceramic	470 pF	50 V SL
C68	Ceramic	470 pF	50 V SL
C69	Ceramic	330 pF	50 V
C70	Barrier Layer	0.047 μF	25 V
C71	Electrolytic	2.2 μF	50 V SS
C72	Barrier Layer	0.1 μF	16 V
C73	Barrier Layer	0.047 μF	25 V
C74	Ceramic	47 pF	50 V
C75	Barrier Layer	0.047 μF	25 V
C76	Barrier Layer	0.047 μF	25 V
C77	Barrier Layer	820 pF	50 V RAU08SA 821K
C78	Cylinder	47 pF	UP125SL
C79	Ceramic	120 pF	50 V
C80	Barrier Layer	0.01 μF	25 V UAT06V 103K
C81	Barrier Layer	0.0033 μF	25 V UAT05V 332K
C82	Barrier Layer	0.01 μF	25 V UAT06V 103K
C83	Barrier Layer	0.0056 μF	25 V UAT06V 562K
C84	Barrier Layer	820 pF	50 V RAU08SA 821K
C85	Barrier Layer	0.0082 μF	25 V UAT06V 822K
C86	Ceramic	100 pF	50 V
C87	Ceramic	33 pF	50 V
C88	Barrier Layer	0.047 μF	25 V
C89	Barrier Layer	0.1 μF	16 V
C90	Ceramic	470 pF	50 V SL
C91	Ceramic	0.0047 μF	50 V
C92	Electrolytic	10 μF	25 V SS
C93	Electrolytic	10 μF	25 V SS
C94	Electrolytic	47 μF	10 V SS
C95	Ceramic	0.0047 μF	50 V
C96	Barrier Layer	0.047 μF	25 V
C97	Electrolytic	100 μF	10 V SS
C98	Barrier Layer	0.047 μF	25 V
C99	Electrolytic	2.2 μF	50 V RC2
C100	Barrier Layer	0.047 μF	25 V
C101	Electrolytic	0.47 μF	50 V RC2
C102	Barrier Layer	0.047 μF	25 V
C103	Electrolytic	0.47 μF	50 V RC2
C104	Electrolytic	1 μF	50 V RC3
C105	Electrolytic	2.2 μF	50 V RC2
C106	Mylar	0.022 μF	50 V F2D
C107	Electrolytic	1 μF	50 V RC2
C108	Mylar	0.022 μF	50 V F2D
C109	Mylar	0.0047 μF	50 V F2D
C110	Ceramic	0.0047 μF	50 V
C111	Electrolytic	10 μF	25 V SS
C112	Ceramic	0.0047 μF	50 V
C113	Electrolytic	10 μF	25 V SS
C114	Ceramic	220 pF	50 V
C115	Array	0.001 μF × 7	B8XC0114-32N
C116	Ceramic	120 pF	50 V UJ
C117	Ceramic	0.0047 μF	50 V
C118	Ceramic	270 pF	50 V UJ
C119	Ceramic	200 pF	50 V XL
C120	Ceramic	220 pF	50 V UJ
C121	Ceramic	200 pF	50 V XL
C122	Ceramic	0.0047 μF	50 V
C123	Barrier Layer	0.047 μF	25 V
C124	Electrolytic	2.2 μF	50 V SS
C125	Ceramic	0.0047 μF	50 V
C126	Electrolytic	22 μF	25 V SS
C127	Electrolytic	10 μF	25 V SS
C128	Ceramic	0.0047 μF	50 V
C129	Electrolytic	22 μF	25 V SS
C131	Ceramic	0.0047 μF	50 V
C132	Ceramic	0.0047 μF	50 V
C133	Ceramic	0.0047 μF	50 V
C134	Electrolytic	47 μF	16 V SS
C135	Ceramic	0.0047 μF	50 V
C136	Electrolytic	22 μF	25 V SS
C137	Ceramic	0.0047 μF	50 V
C138	Electrolytic	22 μF	25 V SS
C139	Barrier Layer	0.047 μF	25 V
C140	Electrolytic	10 μF	25 V SS

[SCOPE UNIT]

REF. NO.	DESCRIPTION	PART NO.
C141	Ceramic	0.0047 $\mu$ F 50 V
C142	Electrolytic	10 $\mu$ F 25 V SS
C143	Ceramic	0.0047 $\mu$ F 50 V
C144	Ceramic	0.001 $\mu$ F 50 V
C145	Ceramic	0.0047 $\mu$ F 50 V
C146	Electrolytic	47 $\mu$ F 16 V SS
C147	Ceramic	0.0047 $\mu$ F 50 V
C148	Ceramic	0.0047 $\mu$ F 50 V
C149	Tantalum	10 $\mu$ F 10 V DN
C150	Ceramic	100 pF 50 V
C151	Ceramic	100 pF 50 V
C152	Ceramic	200 pF 50 V XL
C153	Ceramic	22 pF 50 V
J2	Connector	TLB-P08H-B1
J3	Connector	TL25P-03-V1
J4	Connector	TLB-P04H-B1
J5	Connector	TL25P-04-V1
P1	Connector	TMP-P01X-A1
P2	Connector	TSL-P09H-B1
P3	Connector	TSL-P04H-B1
S1	Switch	SSSS31124A (SCOPE TX SIGNAL)
S2	Switch	SSSS31124A (SPAN SELECTOR)
EP1	P.C. Board	B-1406B

[PI UNIT]

REF. NO.	DESCRIPTION	PART NO.
Q1	Transistor	2SC2458 Y
Q2	Transistor	2SD468 C
Q3	Transistor	2SA798 G
Q4	Transistor	RN1202
Q5	Transistor	RN1202
Q6	Transistor	2SA1048 Y
Q7	Transistor	2SB1019 Y
Q8	Transistor	2SB562 C
Q9	Transistor	2SC1583 G
D1	Bride	KBPC806
D2	Diode	1N4002
D3	Diode	1N4002
D4	Diode	1N4002
D5	Diode	1N4002
D6	Diode	1N4002
D7	Diode	1N4002
D8	Zener	RD8.2E B2
L1	Coil	CL700200JB
L2	Coil	LAL04NA 101K
L3	Coil	LR-92
L4	Coil	LR-92
L5	Coil	LR-92
L6	Coil	LR-92
L7	Coil	LR-92
L8	Coil	LR-66
L9	Coil	LW-15

[PI UNIT]

REF. NO.	DESCRIPTION	PART NO.
R1	Resistor	68 k $\Omega$ R50X
R2	Resistor	68 k $\Omega$ R50X
R3	Absorber	ERZC07DK431
R4	Resistor	10 $\Omega$ R50X
R5	Resistor	10 k $\Omega$ ELR20
R6	Resistor	2.2 k $\Omega$ R20
R7	Resistor	4.7 k $\Omega$ R20
R8	Resistor	5.6 k $\Omega$ R25
R9	Resistor	22 $\Omega$ ELR20
R10	Resistor	22 $\Omega$ ELR20
R11	Resistor	10 k $\Omega$ ELR20
R12	Resistor	220 $\Omega$ R20
R13	Resistor	0.5 $\Omega$ R50X
R14	Resistor	10 k $\Omega$ ELR20
R15	Resistor	220 $\Omega$ R50X
R16	Resistor	4.7 k $\Omega$ ELR20
R17	Resistor	2.2 k $\Omega$ R20
R18	Resistor	330 $\Omega$ ELR20
R19	Resistor	1 k $\Omega$ ELR20
R20	Resistor	SRW2P3-J
C1	Electrolytic	680 $\mu$ F 200 V CS042DRT681
C2	Electrolytic	680 $\mu$ F 200 V CS042DRT681
C3	Electrolytic	680 $\mu$ F 200 V CS042DRT681
C4	Electrolytic	680 $\mu$ F 200 V CS042DRT681
C5	Ceramic	0.0022 $\mu$ F 500 V
C6	Ceramic	0.0022 $\mu$ F 500 V
C7	Ceramic	0.0022 $\mu$ F 500 V
C8	Ceramic	0.0022 $\mu$ F 500 V
C9	Ceramic	0.0047 $\mu$ F 50 V
C10	Electrolytic	220 $\mu$ F 25 V SS
C11	Ceramic	0.0047 $\mu$ F 50 V
C12	Electrolytic	100 $\mu$ F 16 V SS
C13	Ceramic	0.0047 $\mu$ F 50 V
C14	Electrolytic	220 $\mu$ F 25 V SS
C15	Ceramic	0.0047 $\mu$ F 50 V
C16	Electrolytic	220 $\mu$ F 25 V SS
C17	Ceramic	0.0047 $\mu$ F 50 V
C18	Ceramic	0.0047 $\mu$ F 50 V
C19	Ceramic	0.0047 $\mu$ F 50 V
C20	Ceramic	0.0047 $\mu$ F 50 V
C21	Ceramic	0.0047 $\mu$ F 50 V
C22	Ceramic	0.0047 $\mu$ F 50 V
C23	Electrolytic	100 $\mu$ F 25 V SS
C24	Ceramic	0.0047 $\mu$ F 50 V
C25	Electrolytic	470 $\mu$ F 16 V SS
C26	Ceramic	0.001 $\mu$ F 400 V DE7090B102K
C27	Ceramic	0.001 $\mu$ F 400 V DE7090B102K
C28	Electrolytic	10 $\mu$ F 25 V SS
C29	Electrolytic	220 $\mu$ F 25 V SS
C30	Electrolytic	100 $\mu$ F 10 V SS
C31	Electrolytic	10 $\mu$ F 25 V SS
RL1	Relay	VS12MBN-E
RL2	Relay	AJR-3251
J1	Connector	5045-08A
J2	Connector	5045-08A
J3	Connector	TL25P-03-V1
J4	Connector	TL25P-04-V1
J5	Connector	TL25P-12-V1
J6	Connector	TL25P-10-V1
J7	Connector	TL25P-08-V1
J9	Connector	TL25P-07-V1
J10	Connector	TL25P-05-V1
P1	Connector	1396R1
P2	Connector	5250-08
P3	Connector	1545P1

[PI UNIT]

REF. NO.	DESCRIPTION	PART NO.
P4	Connector	1545P1
P5	Connector	1545R1
P6	Connector	MLP-06
T1	Transformer	TP-22
EP3	P.C. Board	B-1409A

[PA UNIT]

REF. NO.	DESCRIPTION	PART NO.
Q1	Transistor	2SC1971
Q2	Transistor	MRF486
Q3	Transistor	MRF486
Q4	Transistor	MRF422
Q5	Transistor	MRF422
Q6	Transistor	2SC2785 EF
Q7	Transistor	2SC2785 EF
Q8	Transistor	2SD1406 Y
Q9	Transistor	RN2204
Q10	Transistor	2SD1406 Y
Q11	Transistor	2SD468 C
Q12	Transistor	RN1204
D1	Diode	MV5
D2	Diode	MV5
D3	Diode	1S953
L1	Coil	LR-142
L2	Coil	LAL04NA 101K
L3	Coil	BT01RN1-A61
L4	Coil	LR-183
L7	Coil	BT01RN1-A61
L8	Coil	BT01RN1-A61
L9	Coil	LR-81
L10	Coil	LR-81
L11	Coil	LR-94
L12	Coil	LR-95
L13	Coil	LA-102
L14	Coil	BT01RN1-A61
L15	Coil	LR-146
L16	Coil	BT01RN1-A61
R1	Resistor	470 Ω R20
R2	Resistor	12 Ω R20
R3	Resistor	470 Ω R20
R4	Resistor	120 Ω R20
R5	Resistor	2.2 Ω ELR20
R6	Resistor	4.7 Ω R50X
R7	Resistor	470 Ω R20
R8	Resistor	120 Ω R25
R9	Resistor	270 Ω R20
R10	Resistor	22 Ω R20
R11	Resistor	220 Ω R50X
R12	Resistor	47 Ω R20
R13	Resistor	220 Ω R50X
R14	Resistor	47 Ω R20
R15	Trimmer	470 Ω RH0421CS2J05A
R16	Resistor	680 Ω R25
R17	Resistor	220 Ω R50X
R18	Resistor	15 Ω CRH100X R-02J
R20	Resistor	3.3 Ω CRH100X R-02J

[PA UNIT]

REF. NO.	DESCRIPTION	PART NO.
R21	Resistor	3.3 Ω CRH100X R-02J
R22	Resistor	3.3 Ω CRH100X R-02J
R23	Resistor	3.3 Ω CRH100X R-02J
R24	Resistor	3.3 Ω CRH100X R-02J
R25	Resistor	3.3 Ω CRH100X R-02J
R26	Resistor	3.3 Ω CRH100X R-02J
R27	Resistor	10 Ω R50X
R28	Resistor	3.3 Ω CRH100X R-02J
R29	Resistor	10 Ω R50X
R30	Resistor	4.7 kΩ ELR20
R31	Trimmer	2.2 kΩ RH0421CJ3J09A
R32	Resistor	4.7 kΩ R20
R34	Resistor	0.012 Ω CP5AJ
R35	Resistor	6.8 Ω CRH300 R-02J
R36	Resistor	3.3 kΩ R20
R37	Resistor	3.3 kΩ R20
R38	Resistor	3.3 kΩ R20
R39	Resistor	3.3 kΩ R20
R40	Resistor	820 Ω R25
R41	Resistor	270 Ω R25
R42	Resistor	1.2 kΩ R50X
R43	Resistor	1 kΩ R20
R44	Resistor	6.8 Ω CRH300 R-02J
R45	Resistor	15 Ω CRH200 R-02J
C1	Ceramic	0.0047 μF 50 V
C2	Barrier Layer	0.0047 μF 25 V UAT05V 472K
C3	Barrier Layer	0.1 μF 16 V
C4	Barrier Layer	0.1 μF 16 V
C5	Ceramic	0.0047 μF 50 V
C6	Ceramic	470 pF 50 V SL
C7	Ceramic	0.047 μF 50 V
C8	Ceramic	0.047 μF 50 V
C10	Barrier Layer	0.0047 μF 25 V
C11	Electrolytic	100 μF 16 V SS
C12	Electrolytic	470 μF 35 V 35SSP470
C13	Ceramic	0.047 μF 50 V
C14	Ceramic	0.0047 μF 50 V
C15	Ceramic	470 pF GR43CH471K
C16	Ceramic	0.0068 μF GR44CH682K
C17	Ceramic	0.0068 μF GR44CH682K
C18	Ceramic	0.001 μF GR44CH102K
C19	Ceramic	0.12 μF GR44-1W5R124M100
C20	Ceramic	0.12 μF GR44-1W5R124M100
C21	Ceramic	82 pF 500 V
C22	Barrier Layer	0.1 μF 16 V
C23	Barrier Layer	0.1 μF 16 V
C24	Barrier Layer	0.047 μF 25 V
C25	Electrolytic	47 μF 25 V SS
C26	Ceramic	0.0047 μF 50 V
C27	Barrier Layer	0.1 μF 16 V
C28	Electrolytic	470 μF 35 V 35SSP470
C29	Ceramic	470 μF 35 V 35SSP470
C30	Ceramic	0.047 μF 50 V
C31	Ceramic	0.0047 μF 50 V
C32	Ceramic	470 pF 50 V
C33	Ceramic	0.0022 μF 50 V
C34	Ceramic	0.0022 μF 50 V
C35	Electrolytic	3.3 μF 50 V SS
C36	Ceramic	0.047 μF 50 V
C37	Ceramic	0.0047 μF 50 V
C38	Ceramic	470 pF 50 V
C39	Ceramic	0.047 μF 50 V
C40	Ceramic	0.0047 μF 50 V
C41	Ceramic	0.0047 μF 50 V
C42	Electrolytic	10 μF 25 V SS
C43	Electrolytic	100 μF 25 V SS
C44	Barrier Layer	0.1 μF 16 V
C45	Electrolytic	22 μF 16 V SS
C46	Barrier Layer	0.0047 μF 25 V
C47	Ceramic	0.0047 μF 50 V
C49	Ceramic	56 pF 1 KV
C50	Electrolytic	3.3 μF 50 V MS7



[PA UNIT]

REF. NO.	DESCRIPTION	PART NO.
J1	Connector	P-423
J2	Connector	P-423
J3	Connector	RT-01T-1.3B
P1	Connector	TMP-P01X-A1
P2	Connector	TMP-P01X-A1
P3	Connector	1625-04R1
S1	Thermal Sensor	OHD-80M
S2	Thermal Sensor	OHDI-50M
MF1	Fan Motor	CF24DC420-908
EP1	P.C. Board	B-1337A
EP2	Ferrite Bead	DL2-OP2.6-3-1.2H
EP3	Ferrite Bead	FSQH050RN
EP4	Ferrite Bead	FSQH050RN
EP5	Ferrite Bead	FSQH050RN
EP6	Ferrite Bead	FSQH070RN
EP19	Ferrite Bead	FSQH050RN
EP21	Ferrite Bead	FSQH070RN

[REG UNIT]

REF. NO.	DESCRIPTION	PART NO.
IC1	IC	μPC1042C
IC2	IC	NJM7805A
Q1	Transistor	2SC3162
Q2	Transistor	2SC3164
Q3	Transistor	2SC3162
Q4	Transistor	2SC3164
Q5	Transistor	2SA1048 GR
Q6	Transistor	2SA1048 GR
Q7	Transistor	2SD1406 Y
Q8	Transistor	2SD468 C
Q9	Transistor	2SD1406 Y
Q10	Transistor	2SC2458 GR
Q11	Transistor	2SC2458 GR
D1	Diode	1N4002
D2	Diode	ESAC85-009
D3	Diode	40F2R15
D4	Diode	1SS133
D5	Zener	RD16E B2
D6	Zener	RD5.1E B2
L2	Coil	LAL04NA 102K
L3	Coil	LR-65A
L4	Coil	LR-67
L5	Coil	SN12D500
L6	Coil	LR-67
L7	Coil	TC-2A
L9	Coil	LAL04NA 102K
L10	Coil	BT01RN1-A61
L11	Coil	LW-15
R1	Resistor	4.7 kΩ R20
R2	Trimmer	10 kΩ RH0651C14J2WA

[REG UNIT]

REF. NO.	DESCRIPTION	PART NO.
R3	Resistor	4.7 kΩ ELR20
R4	Resistor	5.6 kΩ ELR20
R5	Resistor	2.2 kΩ ELR20
R6	Trimmer	47 kΩ RH0651CS4J25A
R7	Resistor	6.8 kΩ ELR20
R8	Resistor	3.9 kΩ R20
R9	Resistor	10 kΩ ELR20
R10	Resistor	220 kΩ R20
R11	Resistor	560 Ω R25
R12	Resistor	18 kΩ ELR20
R13	Resistor	27 kΩ R20
R14	Resistor	4.7 Ω R20
R15	Resistor	22 Ω ELR20
R16	Resistor	3.3 Ω R20
R17	Resistor	4.7 Ω R20
R18	Resistor	22 Ω ELR20
R19	Resistor	3.3 Ω ELR20
R20	Resistor	68 kΩ R50X
R21	Resistor	68 kΩ R50X
R22	Resistor	0.001 Ω
R23	Resistor	3.9 Ω CRH100X R-02J
R24	Resistor	33 Ω R25
R25	Resistor	22 Ω CRH200 R-02J
R26	Resistor	RSF3B100-J
R27	Resistor	2.2 kΩ ELR20
R28	Resistor	10 kΩ R20
R29	Resistor	1 kΩ ELR20
R30	Resistor	22 Ω CRH200 R-02J
R31	Resistor	22 Ω CRH200 R-02J
R32	Resistor	SRW2P2.2-J
R33	Resistor	150 Ω R20
R34	Resistor	470 Ω R20
R35	Resistor	0.5 Ω R50X
R36	Resistor	3.3 kΩ R20
R37	Resistor	5.6 kΩ ELR20
R38	Resistor	2.2 kΩ ELR20
C1	Mylar	0.022 μF 50 V F2D
C2	Ceramic	0.0047 μF 50 V
C3	Ceramic	330 pF 50 V
C4	Electrolytic	47 μF 16 V SS
C5	Barrier Layer	0.22 μF DD410SR224M12
C6	Barrier Layer	0.22 μF DD410SR224M12
C7	Metallized	3.3 μF 400 V TMG2G335K
C8	Electrolytic	33 μF 250V 250RJ33
C9	Electrolytic	33 μF 250V 250RJ33
C10	Ceramic	0.02 μF 500 V
C11	Ceramic	0.001 μF 400 V DE7090B102K
C12	Ceramic	0.001 μF 400 V DE7090B102K
C13	Electrolytic	1000 μF 16 V ECEA1CG102S
C14	Ceramic	0.68 μF C76AF1H684Z
C15	Electrolytic	1000 μF 16 V ECEA1CG102S
C16	Electrolytic	1000 μF 16 V ECEA1CG102S
C17	Ceramic	0.0047 μF 50 V
C19	Ceramic	0.68 μF C76AF1H684Z
C20	Electrolytic	470 μF 35 V ECEA1VF471
C21	Electrolytic	470 μF 35 V ECEA1VF471
C22	Electrolytic	470 μF 35 V ECEA1VF471
C23	Electrolytic	470 μF 35 V ECEA1VF471
C24	Ceramic	0.02 μF 500 V
C25	Ceramic	0.0047 μF 500 V
C26	Ceramic	0.0047 μF 500 V
C27	Ceramic	0.0022 μF 500 V
C28	Ceramic	0.0022 μF 500 V
C29	Electrolytic	22 μF 25 V SS
C30	Barrier Layer	0.047 μF 25 V
C31	Ceramic	0.0047 μF 50 V
C32	Electrolytic	22 μF 25 V SS
C33	Ceramic	0.0047 μF 50 V
C34	Electrolytic	47 μF 10 V SS
C35	Ceramic	0.0047 μF 50 V
C38	Ceramic	0.0047 μF 50 V
C39	Ceramic	0.0047 μF 50 V
C40	Electrolytic	47 μF 16 V SS

[REG UNIT]

REF. NO.	DESCRIPTION	PART NO.
C41	Ceramic	470 pF 50 V SL
C42	Ceramic	0.0022 μF 400 V DE7110F222M
C43	Electrolytic	10 μF 50 V SS
C44	Electrolytic	47 μF 16 V SS
J1	Connector	TLB-P04H-B1
J2	Connector	TL25P-04-V1
J3	Connector	RT-01T-1.3B
J4	Connector	RT-01T-1.3B
J5	Connector	RT-01T-1.3B
J6	Connector	RT-01T-1.0B
J7	Connector	RT-01T-1.0B
J8	Connector	RT-01T-1.0B
J9	Connector	RT-01T-1.0B
J10	Connector	RT-01T-1.0B
J11	Connector	RT-01T-1.0B
J12	Connector	RT-01T-1.0B
J13	Connector	RT-01T-1.0B
J14	Connector	RT-01T-1.0B
J15	Connector	RT-01T-1.0B
J16	Connector	RT-01T-1.0B
J17	Connector	RT-01T-1.0B
P1	Connector	1396P1
P2	Connector	TL25H-03-B1
P3	Connector	1545R1
P4	Connector	TL25H-07-B1
P5	Connector	TL25H-04-B1
P6	Connector	2-S3.3
P7	Connector	2-S3.3
T1	Transformer	TI-8
T2	Transformer	TP-48
EP1	P.C. Board	B-1405A (REG)
EP2	P.C. Board	B-1407B (TR)
EP3	P.C. Board	B-1408B (DI)
EP14	Ferrite Bead	FSQH050RN
EP16	Ferrite Bead	FSQH090RN
EP35	Ferrite Bead	FSQH070RN
EP36	Ferrite Bead	FSQH070RN
EP37	Ferrite Bead	FSQH070RN
EP38	Ferrite Bead	FSQH070RN
EP39	Ferrite Bead	FSQH070RN
EP40	Ferrite Bead	FSQH090RN
EP41	Ferrite Bead	FSQH090RN

[FILTER UNIT]

REF. NO.	DESCRIPTION	PART NO.
L3	Coil	LR-50
L4	Coil	LR-49
L5	Coil	LR-140
L6	Coil	LR-141
L7	Coil	LR-141
L8	Coil	LR-90
L9	Coil	LR-91
L10	Coil	LR-53
L11	Coil	LR-54
L12	Coil	LR-55
L13	Coil	LR-56
L14	Coil	LR-58
L15	Coil	LR-57
L16	Coil	LR-22A
L17	Coil	L6 222K
L18	Coil	LAL04NA 101K
L19	Coil	LAL04NA 101K
L20	Coil	LAL04NA 101K
L21	Coil	LAL04NA 101K
L22	Coil	LAL04NA 101K
L23	Coil	LAL04NA 101K
L24	Coil	LAL04NA 101K
L25	Coil	LAL04NA 101K
L26	Coil	LAL04NA 100K
L27	Coil	LAL04NA 100K
L28	Coil	LAL04NA 100K
L29	Coil	LAL04NA 100K
L30	Coil	LAL04NA 100K
L31	Coil	LAL04NA 100K
L32	Coil	LAL03NA 101K
R1	Resistor	5.6 kΩ R20
R2	Resistor	56 kΩ R20
R3	Resistor	5.6 kΩ R20
R4	Resistor	56 kΩ ELR20
R5	Resistor	68 Ω R50X
R6	Resistor	47 Ω R50X
R7	Resistor	47 Ω R50X
R8	Resistor	47 Ω R50X
C1	Dip Mica	0.0015 μF DM20C152J51CR
C2	Ceramic	330 pF 500 V
C3	Dip Mica	0.0015 μF DM20C152J51CR
C4	Dip Mica	0.0012 μF DM20C122J51CR
C5	Dip Mica	0.0012 μF DM20C122J51CR
C6	Ceramic	330 pF 500 V
C7	Dip Mica	470 pF DM19C471J51CR
C8	Ceramic	220 pF 500 V
C9	Dip Mica	560 pF DM19C561J51CR
C10	Dip Mica	560 pF DM19C561J51CR
C11	Ceramic	82 pF 500 V
C12	Dip Mica	560 pF DM19C561J51CR
C13	Dip Mica	470 pF DM19C471J51CR
C14	Ceramic	120 pF 500 V
C15	Ceramic	200 pF 500 V
C16	Ceramic	330 pF 500 V
C17	Ceramic	68 pF 500 V
C18	Ceramic	270 pF 500 V
C19	Ceramic	220 pF 500 V
C20	Ceramic	33 pF 500 V
C21	Ceramic	150 pF 500 V
C22	Ceramic	150 pF 500 V
C23	Ceramic	180 pF 500 V
C24	Ceramic	75 pF 500 V
C25	Ceramic	220 pF 500 V
C26	Ceramic	150 pF 500 V
C27	Ceramic	22 pF 500 V
C28	Ceramic	150 pF 500 V
C29	Ceramic	180 pF 500 V
C30	Ceramic	56 pF 500 V
C31	Ceramic	120 pF 500 V
C32	Ceramic	82 pF 500 V
C33	Ceramic	18 pF 500 V

[FILTER UNIT]

REF. NO.	DESCRIPTION	PART NO.
D1	Diode	1N4002
D2	Diode	1N4002
D3	Diode	1N4002
D4	Diode	1N4002
D5	Diode	1N4002
D6	Diode	1N4002
D7	Diode	1N4002
D8	Diode	1K60
D9	Diode	1K60
L1	Coil	LR-48
L2	Coil	LR-48

[FILTER UNIT]

REF. NO.	DESCRIPTION	PART NO.
C34	Ceramic	100 pF 500 V
C35	Ceramic	100 pF 500 V
C36	Ceramic	22 pF 500 V
C37	Ceramic	82 pF 500 V
C38	Ceramic	56 pF 500 V
C39	Ceramic	39 pF 500 V
C40	Ceramic	82 pF 500 V
C41	Ceramic	82 pF 500 V
C42	Ceramic	18 pF 500 V
C43	Ceramic	68 pF 500 V
C44	Trimmer	20 pF CV05D2002
C45	Ceramic	150 pF 50 V
C46	Ceramic	0.001 μF 50 V
C47	Ceramic	0.001 μF 50 V
C48	Barrier Layer	0.047 μF 25 V
C49	Barrier Layer	0.047 μF 25 V
C50	Barrier Layer	0.047 μF 25 V
C51	Barrier Layer	0.047 μF 25 V
C52	Barrier Layer	0.047 μF 25 V
C53	Barrier Layer	0.047 μF 25 V
C54	Barrier Layer	0.047 μF 25 V
C55	Barrier Layer	0.047 μF 25 V
C56	Ceramic	0.0047 μF 50 V
C57	Ceramic	0.0047 μF 50 V
C58	Ceramic	0.0047 μF 50 V
C59	Ceramic	0.0047 μF 50 V
C60	Ceramic	0.0047 μF 50 V
C61	Ceramic	0.0047 μF 50 V
C62	Ceramic	22 pF 500 V
RL1	Relay	FBR313D012-22
RL2	Relay	FBR313D012-22
RL3	Relay	FBR313D012-22
RL4	Relay	FBR313D012-22
RL5	Relay	FBR313D012-22
RL6	Relay	FBR313D012-22
RL7	Relay	FBR313D012-22
RL8	Relay	FBR313D012-22
RL9	Relay	FBR313D012-22
RL10	Relay	FBR311D012
RL11	Relay	FBR313D012-22
RL12	Relay	FBR311D012
RL13	Relay	FBR313D012-22
RL14	Relay	FBR311D012
J1	Connector	TMP-J01X-V2
J2	Connector	TMP-J01X-V2
J3	Connector	TL25P-03-V1
P1	Connector	TL25H-07-B1
EP1	P.C. Board	B-1338B
W28	Jumper	JPW-02A

[DC-DC UNIT]

REF. NO.	DESCRIPTION	PART NO.
Q1	Transistor	2SD468 C
Q2	Transistor	2SD468 C
D1	Diode	1SS53
D2	Diode	1SS53
D3	Diode	V19 B
D4	Diode	V19 B
L1	Coil	FL9H 471K
L2	Coil	TO-8A
L3	Coil	FL9H 471K
R1	Resistor	4.7 kΩ ELR25
R2	Resistor	4.7 kΩ ELR25
R3	Resistor	33 Ω ELR25
R4	Resistor	33 Ω ELR25
R5	Resistor	470 Ω ELR25
C1	Electrolytic	10 μF 16 V SS
C2	Ceramic	0.68 μF C76AF1H684Z
C3	Electrolytic	220 μF 10 V SS
C4	Electrolytic	220 μF 10 V SS
C5	Tantalum	0.47 μF 35 V DN
C6	Tantalum	0.47 μF 35 V DN
C7	Tantalum	0.47 μF 35 V DN
C8	Tantalum	0.47 μF 35 V DN
C9	Mylar	0.0047 μF 50 V F2D
C10	Electrolytic	3.3 μF 50 V SS
C11	Ceramic	0.0047 μF 50 V
C12	Electrolytic	10 μF 25 V SS
C13	Ceramic	0.68 μF C76AF1H684Z
P1	Connector	TL25H-03-B1
EP1	P.C. Board	B-557

[TUNER UNIT]

REF. NO.	DESCRIPTION	PART NO.
IC1	IC	NJM4558D
IC2	IC	NJM4558D
IC3	IC	SN74S132N
IC4	IC	SN74S00N
IC5	IC	SN74S112N
IC6	IC	TA78L005AP
IC101	IC	M54562P
IC102	IC	μPD4071BC
Q1	Transistor	2SD468 C
Q2	Transistor	2SB562 C
Q3	Transistor	2SC2785 EF
Q4	Transistor	2SA1048 Y/GR
Q5	Transistor	2SC2785 EF
Q6	Transistor	2SA1048 Y/GR
Q7	Transistor	2SD468 C
Q8	Transistor	2SB562 C
Q9	Transistor	2SC2785 EF
Q10	Transistor	2SA1048 Y/GR
Q11	Transistor	2SC2785 EF
Q12	Transistor	2SA1048 Y/GR
Q13	Transistor	2SC1740 S
Q14	Transistor	2SC1740 S

[TUNER UNIT]

REF. NO.	DESCRIPTION	PART NO.
Q15	FET	2SK30ATM Y
Q17	Transistor	2SB562 C
Q18	Transistor	RN1202
Q19	Transistor	2SA1048 GR
Q20	Transistor	RN1204
Q21	Transistor	RN1204
Q22	Transistor	2SB562 C
Q101	Transistor	2SC2785 EF
Q102	Transistor	2SC2785 EF
Q103	Transistor	2SC2785 EF
Q104	Transistor	2SC2785 EF
Q105	Transistor	2SC2785 EF
Q106	Transistor	2SA1348
Q107	Transistor	2SC3402
D1	Zener	RD3.0E B2
D2	Zener	RD3.0E B2
D3	Diode	1S953
D4	Diode	1S953
D5	Zener	RD3.0E B2
D6	Zener	RD3.0E B2
D7	Diode	1S953
D8	Diode	1S953
D9	Diode	1N4002
D10	Diode	1SS133
D11	Diode	1SS133
D13	Diode	1K60
D14	Diode	1K60
D15	Diode	1K60
D16	Diode	1K60
D17	Diode	1SS133
D18	Zener	RD6.2E B2
D19	Diode	1N4002
D20	Diode	1N4002
D21	Diode	1N4002
D22	Diode	1SS133
D23	Diode	1SS133
D101	Diode	1SS133
D102	Diode	1SS133
D103	Diode	1SS133
D104	Diode	1SS133
D105	Diode	1SS133
D106	Diode	1SS133
D107	Diode	1SS133
D108	Diode	1SS133
D109	Diode	1SS133
D110	Diode	1SS133
D111	Diode	1SS133
D112	Diode	1SS133
D113	Diode	1SS133
D114	Diode	1SS133
D115	Diode	1SS133
D116	Diode	1SS133
D117	Diode	1SS133
D118	Diode	1SS133
D119	Diode	1SS133
D120	Diode	1SS133
D121	Diode	1SS133
D122	Zener	RD7.5E B2
D123	Diode	1SS133
D124	Diode	1SS133
D125	Diode	1SS133
D126	Diode	1SS133
D127	Diode	1SS133
D128	Diode	1SS133
D129	Diode	1SS133
D130	Diode	1SS133
D131	Diode	1SS133
D132	Diode	1SS133
D133	Diode	1SS133
D134	Diode	1SS133
D135	Zener	RD12E B2
D136	Zener	RD5.1E B2
D137	Diode	1SS133

[TUNER UNIT]

REF. NO.	DESCRIPTION	PART NO.
D201	Diode	1SS133
D202	Diode	1SS133
L1	Coil	LAL04NA 101K
L2	Coil	LAL04NA 101K
L3	Coil	LAL04NA 101K
L4	Coil	LAL04NA 101K
L5	Coil	LAL04NA 101K
L6	Coil	LR-127A
L7	Coil	L6 222K
L8	Coil	LW-18A
L9	Coil	LW-18A
L10	Coil	LAL04NA 101K
L11	Coil	LAL04NA 101K
L12	Coil	LAL04NA 101K
L13	Coil	LAL04NA 101K
L15	Coil	LAL04NA 101K
L17	Coil	FL9H 102J
L18	Coil	LAL03NA 101K
L19	Coil	LAL03NA 101K
L101	Coil	LAL04NA 101K
L102	Coil	LAL04NA 101K
L103	Coil	LAL03NA 101K
L201	Coil	LAL03NA 101K
L202	Coil	LAL03NA 101K
L204	Coil	LAL03NA 101K
L205	Coil	LAL03NA 101K
L206	Coil	LAL03NA 101K
L207	Coil	LAL03NA 101K
L208	Coil	LAL03NA 101K
L209	Coil	LAL03NA 101K
L210	Coil	LA-162
L211	Coil	LR-185
L212	Coil	LR-186
L213	Coil	LR-187
R1	Resistor	150 Ω R20
R2	Resistor	1.5 kΩ R20
R3	Resistor	47 kΩ R20
R4	Resistor	2.2 MΩ ELR20
R5	Resistor	47 kΩ R20
R6	Resistor	33 kΩ R20
R7	Resistor	33 kΩ ELR20
R8	Resistor	22 MΩ ERC14GJ
R9	Resistor	2.2 MΩ ELR20
R10	Resistor	2.2 MΩ ELR20
R11	Resistor	1 kΩ R20
R12	Resistor	22 kΩ ELR20
R13	Resistor	22 kΩ R20
R14	Resistor	15 kΩ R20
R15	Resistor	100 kΩ R20
R16	Resistor	100 kΩ R20
R17	Resistor	150 Ω R20
R18	Resistor	1.5 kΩ R20
R19	Resistor	47 kΩ ELR20
R20	Resistor	2.2 MΩ ELR20
R21	Resistor	47 kΩ R20
R22	Resistor	33 kΩ ELR20
R23	Resistor	33 kΩ ELR20
R24	Resistor	22 MΩ ERC14GJ
R25	Resistor	2.2 MΩ ELR20
R26	Resistor	2.2 MΩ ELR20
R27	Resistor	1 kΩ R20
R28	Resistor	22 kΩ R20
R29	Resistor	22 kΩ R20
R30	Resistor	15 kΩ ELR20
R31	Resistor	100 kΩ R20
R32	Resistor	100 kΩ R20
R34	Resistor	33 Ω R50X
R35	Resistor	15 kΩ R20
R36	Resistor	12 kΩ R20
R37	Resistor	15 kΩ R20
R38	Resistor	12 kΩ R20



[TUNER UNIT]

REF. NO.	DESCRIPTION	PART NO.
R39	Resistor	330 Ω R20
R40	Resistor	2.2 kΩ R20
R41	Resistor	2.2 kΩ R20
R42	Resistor	1 kΩ R20
R43	Resistor	39 Ω R20
R44	Resistor	33 Ω R50X
R45	Resistor	10 kΩ R20
R46	Resistor	10 kΩ R20
R47	Resistor	1 MΩ R20
R48	Resistor	10 kΩ R20
R49	Resistor	4.7 kΩ R20
R50	Resistor	1 kΩ R20
R51	Resistor	39 Ω R20
R52	Resistor	39 Ω R20
R53	Resistor	820 Ω R20
R54	Resistor	560 Ω R20
R55	Resistor	22 kΩ R20
R56	Resistor	10 kΩ R20
R57	Resistor	2.2 kΩ R20
R58	Resistor	470 Ω R20
R59	Resistor	100 Ω R20
R60	Resistor	4.7 kΩ R50X
R61	Resistor	4.7 kΩ R50X
R62	Resistor	4.7 kΩ R50X
R63	Resistor	4.7 kΩ R50X
R64	Resistor	4.7 kΩ R50X
R65	Resistor	4.7 kΩ R50X
R66	Resistor	4.7 kΩ R50X
R67	Resistor	4.7 kΩ R50X
R68	Resistor	10 kΩ R20
R69	Resistor	10 kΩ R20
R70	Resistor	2.2 kΩ R20
R71	Absorber	DSA301 L
R72	Resistor	4.7 kΩ R50X
R73	Resistor	4.7 kΩ R50X
R101	Trimmer	10 kΩ B×7 RK09Z773000EA
R102	Trimmer	10 kΩ B×7 RK09Z773000EA
R103	Resistor	100 kΩ R20
R104	Resistor	100 kΩ R20
R105	Resistor	100 kΩ R20
R106	Resistor	100 kΩ R20
R107	Resistor	100 kΩ R20
R108	Resistor	100 kΩ R20
R109	Resistor	100 kΩ ELR20
R110	Resistor	47 kΩ ELR20
R111	Resistor	100 kΩ R20
R112	Resistor	100 kΩ ELR20
R113	Resistor	33 kΩ ELR20
R114	Resistor	560 kΩ ELR20
R115	Resistor	100 kΩ ELR20
R116	Resistor	47 kΩ ELR20
R117	Resistor	1 MΩ ELR20
R118	Resistor	47 kΩ ELR20
R119	Resistor	10 kΩ ELR20
R120	Resistor	10 kΩ R20
R121	Resistor	2.7 kΩ ELR20
R122	Resistor	10 kΩ ELR20
R123	Resistor	2.7 kΩ ELR20
R124	Resistor	2.2 kΩ ELR20
R125	Resistor	2.7 kΩ ELR20
R127	Resistor	27 kΩ ELR20
R128	Resistor	10 kΩ R20
R129	Resistor	33 kΩ R20
R301	Variable Resistor	10 kΩ B EVH60AF15B14
R302	Variable Resistor	10 kΩ B EVH60AF15B14
C1	Ceramic	0.0047 μF 50 V
C2	Ceramic	0.0047 μF 50 V
C3	Ceramic	0.0047 μF 50 V
C4	Ceramic	0.0047 μF 50 V
C5	Ceramic	0.0047 μF 50 V
C6	Ceramic	0.0047 μF 50 V
C7	Ceramic	0.0047 μF 50 V
C8	Ceramic	0.0047 μF 50 V

[TUNER UNIT]

REF. NO.	DESCRIPTION	PART NO.
C9	Ceramic	0.0047 μF 50 V
C10	Barrier Layer	0.0047 μF 25 V
C11	Barrier Layer	0.0047 μF 25 V
C12	Barrier Layer	0.001 μF 25 V
C13	Barrier Layer	0.001 μF 25 V
C14	Ceramic	0.0047 μF 50 V
C15	Ceramic	0.0047 μF 50 V
C16	Ceramic	0.0047 μF 50 V
C17	Ceramic	0.0047 μF 50 V
C18	Ceramic	0.0047 μF 50 V
C19	Ceramic	0.0047 μF 50 V
C20	Ceramic	0.001 μF 50 V
C21	Ceramic	0.0047 μF 50 V
C22	Ceramic	0.0047 μF 50 V
C23	Ceramic	0.0047 μF 50 V
C24	Ceramic	0.0047 μF 50 V
C25	Barrier Layer	0.0047 μF 25 V
C26	Barrier Layer	0.0047 μF 25 V
C27	Barrier Layer	0.001 μF 25 V
C28	Barrier Layer	0.001 μF 25 V
C29	Ceramic	0.0047 μF 50 V
C30	Ceramic	0.0047 μF 50 V
C31	Ceramic	0.0047 μF 50 V
C32	Electrolytic	10 μF 25 V SS
C33	Ceramic	0.0047 μF 50 V
C34	Electrolytic	10 μF 25 V SS
C35	Electrolytic	47 μF 25 V SS
C36	Ceramic	0.0047 μF 50 V
C37	Ceramic	0.0047 μF 50 V
C38	Ceramic	0.0047 μF 50 V
C39	Electrolytic	10 μF 25 V SS
C40	Ceramic	5 pF 500 V
C42	Ceramic	10 pF 500 V
C43	Ceramic	330 pF 50 V
C44	Trimmer	210 pF BW3P
C45	Ceramic	0.0047 μF 50 V
C46	Ceramic	0.0047 μF 50 V
C47	Ceramic	0.0047 μF 50 V
C48	Ceramic	0.0047 μF 50 V
C49	Ceramic	0.001 μF 50 V
C50	Ceramic	0.0047 μF 50 V
C51	Ceramic	0.0047 μF 50 V
C52	Ceramic	0.0047 μF 50 V
C53	Ceramic	0.0047 μF 50 V
C54	Ceramic	0.0047 μF 50 V
C55	Ceramic	0.0047 μF 50 V
C56	Electrolytic	10 μF 25 V SS
C57	Electrolytic	10 μF 25 V SS
C58	Ceramic	0.0047 μF 50 V
C59	Ceramic	0.0047 μF 50 V
C60	Ceramic	0.047 μF 25 V
C61	Ceramic	0.047 μF 25 V
C62	Ceramic	0.0047 μF 50 V
C63	Ceramic	0.0047 μF 50 V
C65	Ceramic	0.0047 μF 50 V
C66	Ceramic	0.0047 μF 50 V
C67	Electrolytic	22 μF 25 V SS
C68	Electrolytic	22 μF 25 V SS
C69	Ceramic	0.0047 μF 50 V
C70	Ceramic	0.0047 μF 50 V
C71	Ceramic	0.0047 μF 50 V
C72	Ceramic	0.0047 μF 50 V
C73	Ceramic	0.0047 μF 50 V
C74	Ceramic	0.0047 μF 50 V
C75	Ceramic	0.0047 μF 50 V
C76	Ceramic	0.0047 μF 50 V
C77	Ceramic	0.0047 μF 50 V
C78	Ceramic	0.0047 μF 50 V
C79	Ceramic	0.0047 μF 50 V
C80	Ceramic	0.047 μF 25 V
C101	Array	0.0082 μF×7 B8ZC0111-32N
C102	Array	0.0082 μF×7 B8ZC0111-32N
C103	Ceramic	0.0047 μF 50 V
C104	Ceramic	0.0047 μF 50 V
C105	Ceramic	0.0047 μF 50 V

[TUNER UNIT]

REF. NO.	DESCRIPTION	PART NO.
C106	Ceramic	0.0047 $\mu$ F 50 V
C107	Ceramic	0.0047 $\mu$ F 50 V
C108	Ceramic	0.0047 $\mu$ F 50 V
C109	Ceramic	0.0047 $\mu$ F 50 V
C110	Ceramic	0.0047 $\mu$ F 50 V
C111	Ceramic	0.0047 $\mu$ F 50 V
C112	Ceramic	0.0047 $\mu$ F 50 V
C113	Ceramic	0.0047 $\mu$ F 50 V
C114	Ceramic	0.0047 $\mu$ F 50 V
C115	Ceramic	0.0047 $\mu$ F 50 V
C116	Ceramic	0.0047 $\mu$ F 50 V
C117	Barrier Layer	0.1 $\mu$ F 16 V
C118	Barrier Layer	0.1 $\mu$ F 16 V
C119	Barrier Layer	0.1 $\mu$ F 16 V
C120	Barrier Layer	0.1 $\mu$ F 16 V
C121	Barrier Layer	0.1 $\mu$ F 16 V
C122	Barrier Layer	0.1 $\mu$ F 16 V
C123	Barrier Layer	0.1 $\mu$ F 16 V
C124	Barrier Layer	0.1 $\mu$ F 16 V
C125	Electrolytic	10 $\mu$ F 25 V RC3
C126	Barrier Layer	0.0047 $\mu$ F 25 V
C127	Barrier Layer	0.0047 $\mu$ F 25 V
C128	Barrier Layer	0.0047 $\mu$ F 25 V
C129	Barrier Layer	0.0047 $\mu$ F 25 V
C130	Barrier Layer	0.0047 $\mu$ F 25 V
C131	Electrolytic	47 $\mu$ F 25 V SS
C132	Barrier Layer	0.0047 $\mu$ F 25 V
C133	Barrier Layer	0.0047 $\mu$ F 25 V
C134	Electrolytic	10 $\mu$ F 25 V RC3
C135	Electrolytic	2.2 $\mu$ F 50 V MS5
C201	Ceramic	120 pF 3KV DE1107 SL 121J
C202	Ceramic	120 pF 3KV DE1107 SL 121J
C203	Ceramic	100 pF 3KV DE1007 SL 101J
C204	Ceramic	100 pF 3KV DE1007 SL 101J
C205	Ceramic	0.0047 $\mu$ F 50 V
C206	Ceramic	0.0047 $\mu$ F 50 V
C208	Ceramic	0.0047 $\mu$ F 50 V
C209	Ceramic	0.0047 $\mu$ F 50 V
C210	Ceramic	0.0047 $\mu$ F 50 V
C211	Ceramic	0.0047 $\mu$ F 50 V
C212	Ceramic	0.0047 $\mu$ F 50 V
C213	Ceramic	0.0047 $\mu$ F 50 V
C214	Ceramic	0.0047 $\mu$ F 50 V
C301	Barrier Layer	0.047 $\mu$ F 25 V
C302	Barrier Layer	0.047 $\mu$ F 25 V
C303	Variable Resistor	200 pF UV44
C304	Variable Resistor	200 pF UV44
RL1	Relay	RZ12
RL2	Relay	OJE-SH-112DM
RL3	Relay	OJE-SH-112DM
RL4	Relay	OJE-SH-112DM
RL5	Relay	OJE-SH-112DM
RL6	Relay	OJE-SH-112DM
RL201	Relay	FBR323D012
RL202	Relay	FBR323D012
RL204	Relay	FX-12M
RL205	Relay	FX-12M
RL206	Relay	FX-12M
RL207	Relay	FX-12M
RL208	Relay	FX-12M
RL209	Relay	FX-12M
J1	Connector	TL25P-08-V1
J101	Connector	TLB-P08H-B1
J102	Connector	TL25P-07-V1
J103	Connector	TL25P-08-V1
J104	Connector	TL25P-05-V1
J105	Connector	TL25P-03-V1
J106	Connector	TL25P-04-V1
J107	Connector	TL25P-04-V1
J108	Connector	TL25P-05-V1

[TUNER UNIT]

REF. NO.	DESCRIPTION	PART NO.
P2	Connector	TL25H-04-B1
P3	Connector	TL25H-04-B1
P4	Connector	TL25H-05-B1
P5	Connector	TMP-P01X-A1
P6	Connector	TMP-P01X-A1
P201	Connector	TL25H-08-B1
P301	Connector	TL25H-08-B1
P303	Connector	TL25H-08-B1
DS1	LED	TLR123
DS2	LED	TLR123
DS3	LED	TLR123
DS4	LED	TLR123
S1	Switch	EVQ-RBA
MF1	Motor	HMK2601-01-030
MF2	Motor	HMK2601-01-030
EP1	P.C. Board	B-1410A (TUNER 1)
EP2	P.C. Board	B-1411B (TUNER 2)
EP3	P.C. Board	B-1412B (PRESET)
EP4	Ferrite Bead	FSQH070RN
EP6	Ferrite Bead	FSQH070RN

[EF (CONNECTOR 1, 2) UNIT]

REF. NO.	DESCRIPTION	PART NO.
Q1	Transistor	RN1202
Q2	Transistor	2SC2458
Q101	Transistor	2SB562 C
Q102	Transistor	2SD468 C
Q103	Transistor	RN1204
Q104	Transistor	RN1204
D1	Diode	1SS53
D101	Diode	GM-3B
D102	Diode	1SS53
D103	Diode	1SS53
D104	Zener	RD3.0E B2
FI1	LC	EXC-EMT103C
FI2	LC	EXC-EMT103C
FI3	LC	EXC-EMT103C
FI4	LC	EXC-EMT103C
FI5	LC	EXC-EMT103C
FI6	LC	EXC-EMT103C
FI7	LC	EXC-EMT103C
FI8	LC	EXC-EMT103C
FI9	LC	EXC-EMT103C
FI10	LC	EXC-EMT103C
FI11	LC	EXC-EMT103C
FI12	LC	EXC-EMT103C
FI13	LC	EXC-EMT103C
FI14	LC	EXC-EMT103C
FI101	LC	EXC-EMT103C
FI102	LC	EXC-EMT103C
FI103	LC	EXC-EMT103C
L1	Coil	BT01RN1-A61

## [EF (CONNECTOR 1, 2) UNIT]

REF. NO.	DESCRIPTION	PART NO.	
L2	Coil	BT01RN1-A61	
L3	Coil	BT01RN1-A61	
L4	Coil	BT01RN1-A61	
L5	Coil	BT01RN1-A61	
L6	Coil	BT01RN1-A61	
L7	Coil	BT01RN1-A61	
L8	Coil	BT01RN1-A61	
L9	Coil	LR-61	
L10	Coil	LR-61	
L101	Coil	FL9H 471K	
L102	Coil	FL9H 471K	
L103	Coil	BT01RN1-A61	
L104	Coil	BT01RN1-A61	
L105	Coil	L6 101K 100 $\mu$	
L106	Coil	LA-268	
L107	Coil	LA-267	
L108	Coil	LA-267	
L109	Coil	BT01RN1-A61	
L110	Coil	BT01RN1-A61	
L111	Coil	FL9H 471K	
L112	Coil	FL9H 471K	
R1	Resistor	330 $\Omega$	R20
R2	Resistor	10 k $\Omega$	R20
R3	Resistor	1 k $\Omega$	ELR20
R4	Resistor	2.2 k $\Omega$	R20
R5	Resistor	2.2 k $\Omega$	ELR20
R101	Resistor	68 $\Omega$	CP5AK
R103	Resistor	10 k $\Omega$	R20
R104	Resistor	1 k $\Omega$	R20
R105	Resistor	1 k $\Omega$	R20
R106	Resistor	10 k $\Omega$	R20
R107	Resistor	1 k $\Omega$	R20
R108	Resistor	1 k $\Omega$	R20
R109	Resistor	330 $\Omega$	R20
R110	Resistor	330 $\Omega$	R20
R111	Resistor	1 k $\Omega$	R20
R112	Trimmer	10 k $\Omega$	RH0652C14J0FA
R113	Resistor	10 k $\Omega$	ELR20
C1	Barrier Layer	0.047 $\mu$ F	25 V
C2	Electrolytic	10 $\mu$ F	16 V SS
C3	Barrier Layer	0.047 $\mu$ F	25 V
C4	Ceramic	0.0047 $\mu$ F	50 V
C5	Ceramic	0.01 $\mu$ F	50 V
C6	Ceramic	0.01 $\mu$ F	50 V
C101	Ceramic	0.12 $\mu$ F	GR44-1W5R124M100
C102	Ceramic	0.12 $\mu$ F	GR44-1W5R124M100
C103	Barrier Layer	0.047 $\mu$ F	25 V
C104	Barrier Layer	0.047 $\mu$ F	25 V
C105	Ceramic	0.0047 $\mu$ F	50 V
C106	Barrier Layer	0.047 $\mu$ F	25 V
C107	Ceramic	0.0047 $\mu$ F	50 V
C108	Barrier Layer	0.047 $\mu$ F	25 V
C109	Ceramic	0.0047 $\mu$ F	50 V
C110	Barrier Layer	0.1 $\mu$ F	16 V
C111	Ceramic	56 pF	50 V
C112	Ceramic	27 pF	50 V
C113	Ceramic	120 pF	50 V
C114	Ceramic	51 pF	50 V
C115	Ceramic	100 pF	50 V
C116	Ceramic	0.0047 $\mu$ F	50 V
C117	Ceramic	0.0047 $\mu$ F	50 V
C118	Ceramic	470 pF	50 V
C119	Ceramic	0.0047 $\mu$ F	50 V
C120	Ceramic	0.0047 $\mu$ F	50 V
RL1	Relay	SY12	
RL101	Relay	UPM-12905Y	
RL102	Relay	NR-HD-6V	

## [EF (CONNECTOR 1, 2) UNIT]

REF. NO.	DESCRIPTION	PART NO.
J1	Connector	TCS4680-01-1111
J2	Connector	TCS4670-01-1111
J3	Connector	TCS4680-01-1111
J4	Connector	HSJ0807-01-010
J5	Connector	HSJ0807-01-010
J6	Connector	HSJ0807-01-010
J7	Connector	HSJ0807-01-010
J8	Connector	TMP-J01X-A2
J9	Connector	TL25P-10-V1
J10	Connector	TL25P-06-V1
J11	Connector	TL25P-04-V1
J12	Connector	TL25P-04-V1
J13	Connector	10DEEG3M
J101	Connector	JPJ2545-01-510
J102	Connector	JPJ2545-01-510
J103	Connector	JPJ2545-01-510
J104	Connector	JPJ2545-01-510
J105	Connector	JPJ2545-01-510
J106	Connector	JPJ2545-01-510
J107	Connector	JPJ2545-01-510
J108	Connector	HLJ4306-01-3080
J109	Connector	TMP-J01X-V6
J110	Connector	TL25P-04-V1
J111	Connector	TL25P-03-V1
J112	Connector	TL25P-05-V1
J113	Connector	MR-DSE-02
J114	Connector	TMP-J01X-A2
J116	Connector	RT-01T-1.0B
J117	Connector	RT-01T-1.0B
P1	Connector	1545R1
P2	Connector	5250-03A
P3	Connector	TMP-P01X-A1
P4	Connector	TMP-P01X-A1
P5	Connector	TMP-P01X-A1
P101	Connector	TMP-P01X-A1
P102	Connector	TL25H-03-B1
P103	Connector	TMP-P01X-A1
F1	Fuse	FGB 10 A (U.S.A.)
F2	Holder	FH-032C
F3	Fuse	FGB 2 A
F4	Holder	SN-5051
F5	Holder	SN-5051
F6	Fuse	FGB 5 A (Australia, Europe, France)
SP1	Speaker	C100P21A0001
EP1	P.C. Board	B-1341B (CONNECTOR 1)
EP101	Cable	OPC-026
EP103	P.C. Board	B-1342B (CONNECTOR 2)
EP104	Ferrite Bead	FSQH070RN
W101	Jumper	JPW-02A
W102	Jumper	JPW-02A
W103	Jumper	JPW-02A

**[COAXIAL CABLE WITH CONNECTOR]**

REF. NO.	PART NO.	ORDER NO.
PLL-A P5~ RF J7	{ 62/99/320/C31/W13D 08 D }	9056002003
PLL-A P6~ PLL-B J11	{ 61/99/160/C31/W13D 08 D }	9054500380
PLL-A P7~ PLL-B J9	{ 61/99/150/C31/W13D 08 D }	9054500370
PLL-A P8~ PLL-B J8	{ 61/99/195/C31/W13D 08 D }	9054500360
PLL-A P9~ MAIN J1	{ 62/99/505/C31/W13D 08 D }	9054500280
PLL-A P10~ RF J5	{ 62/99/495/C31/W13D 08 D }	9054500290
PLL-B P5~ RF J4	{ 62/99/230/C31/W13D 08 D }	9026005033
EF (2) P101~ RF J9	{ 62/99/520/W13D/C31 08 }	9054500040
EF (2) P103~ FILTER J2	{ 62/99/510/W13D/C31 08 }	9054500050
IF P2~ MAIN J11	{ 62/99/215/C31/W13D 08 D }	9054400160
IF P4~ MAIN J10	{ 62/99/280/C31/W13D 08 D }	9026353001
IF P5~ MAIN J13	{ 62/99/470/C31/W13D 08 D }	9054500170
IF P6~ PLL-A J5	{ 62/99/130/C31/W13D 08 D }	9040104033
SCOPE P1~ RF J8	{ 62/99/500/C31/W13A 00 A }	9054500630
PA P1~ RF J13	{ 62/99/320/C31/W13D 08 D }	9056002003
PA P2~ FILTER J1	{ 62/99/300/C31/W13D 08 D }	9047905002
TUNER P5~ EF (2) J109	{ 62/13/300/C31/W13D 08 D }	9054500550
TUNER P6~ EF (2) J114	{ 62/13/210/C31/W13D 08 D }	9054500560
LOGIC-A P5~ DISPLAY	{ 62/99/270/W11D/F 08 }	9054500410
LOGIC-A P7~ EF (1) J8	{ 62/99/470/C31/W11D 08 }	9054500420
PLL-A (J9) P3~ MAIN (J14)	{ 62/99/480/C31/C31 08 }	9054500060
PLL-A (J6) P4~ MAIN (J12)	{ 62/99/430/C31/C31 08 }	9054500070
IF (J13) P5~ RF (J6)	{ 62/99/320/C31/C31 08 }	9054500700



## Icom Inc.

6-9-16, Kamihigashi, Hirano-ku, Osaka 547, Japan  
Phone: 06 793 5301  
Fax : 06 793 0013  
Telex : 05277822 ICOMTR J

### Icom America Inc.

<Corporate Headquarters>  
2380 116th Avenue N.E., Bellevue, WA 98004, U.S.A.  
Phone: (206) 454-8155  
Fax : (206) 454-1509  
Telex : 152210 ICOM AMER BVUE

<Customer Service>  
Phone: (206) 454-7619

<Regional Customer Service Centers>  
3150 Premier Drive, Suite 126, Irving, TX 75063, U.S.A.  
Phone: (214) 550-7525  
Fax : (214) 550-7423

1777 Phoenix Parkway, Suite 201, Atlanta, GA 30349, U.S.A.  
Phone: (404) 991-6166  
Fax : (404) 991-6327

### Icom Canada

A Division of Icom America Inc.  
3071 #5 Road, Unit 9, Richmond, B.C., V6X 2T4, Canada  
Phone: (604) 273-7400  
Fax : (604) 273-1900

### Icom (Europe) GmbH

Communication Equipment  
Himmelgeister Str. 100, 4000 Düsseldorf 1, W. Germany  
Phone: 0211 346047  
Fax : 0211 333639  
Telex : 8588082 ICOM D

### Icom (Australia) Pty. Ltd.

Incorporated in Victoria  
7 Duke Street, Windsor, Victoria, 3181, Australia  
Phone: 03 529 7582, 03 529 8765  
Fax : 03 529 8485  
Telex : AA 35521 ICOM AS

### Icom (UK) Ltd.

Unit 9, Sea St., Herne Bay, Kent, U.K.  
Phone: 0227 363859  
Fax : 0227 360155  
Telex : 965179 ICOM G

### Icom France S.a

120 Route de Revel, BP4063, 31029 Toulouse Cedex, France  
Phone: 61. 20. 31. 49  
Fax : 61. 34. 05. 91  
Telex : 521515 ICOM FRA

Count on us!

Icom Inc.

6-9-16, Kamihigashi, Hirano-ku, Osaka 547, Japan